

# Installation Instructions for 55015 & 55025

## Dragster Scoop Mount

Available for 4150, 4500 & Demon style carburetors.

### Installation Instructions:

#### Pre-assembly:

1. Install one(1) 1-1/2" long set screw into the hex shaped end of each stand-off using Red Loctite thread locker.
2. Fasten the stand-off's to the adapter plate by using one(1) flat head screw each from the underside of the adapter plate. A Red Loctite applied to the threads is recommended.
3. Install supplied return spring and cable brackets using supplied 1/4" washers and button head screws.

#### Assembly:

1. Install 4-hole flange gasket over manifold stud bolts (Not Included).
2. Slide pre-assembled adapter plate over manifold stud bolts, followed by another 4-hole flange gasket (Not Included).
3. Install carburetor over manifold stud bolts. Tighten down in a criss cross pattern no tighter than 60 in-lbs. (Not Included).
4. Install the rear cable mount to the bracket with the supplied attaching screw. Do not tighten at this allow for adjustment in step (6).
5. Units with the return spring feature should be installed now with the supplied attaching screw. Do not tighten at this time to allow for adjustment in step (6).
6. Method A: Holley 4150/4160 & Edelbrock. Install the carburetor linkage return spring bracket to the carburetor linkage by placing it between the linkage and the carburetor main body. Use a drop of Red Loctite on the threads and tighten only enough to allow the arm to pivot freely. Caution – Allow the Loctite to dry thoroughly prior to use. Method B: Holley 4150/4160 & Edelbrock. Utilize the same procedure as outlined above, use Holley # 510-20-37 or Edelbrock # 350-8009. This will double as the mounting screw and cable attachment.
7. For the Holley Dominator install the carburetor linkage return spring bracket to the carburetor linkage upper hole by placing it between the linkage and the carburetor main body. Use a drop of Red Loctite on the threads and tighten only enough to allow the arm to pivot freely. Caution - Allow the Loctite to dry thoroughly prior to use.
8. The final adjustment to the cable is to allow for the full range of operation and to secure the fastener(s).
9. Units with the return spring feature, adjust to the required tension and secure the fastener.
10. Place air cleaner gasket onto carburetor (Not Included).
11. Place supplied 1/4" washer over stand-off set screw: (4150 = 1 each), (Road/Race Demon = 1each), (4500 = 1 each) & (King Demon = 2 each).
12. Install scoop tray over stand-off set screws and center on carburetor.
13. Fasten scoop tray down using supplied 1/4" washers and Nylock Self-Locking nuts.

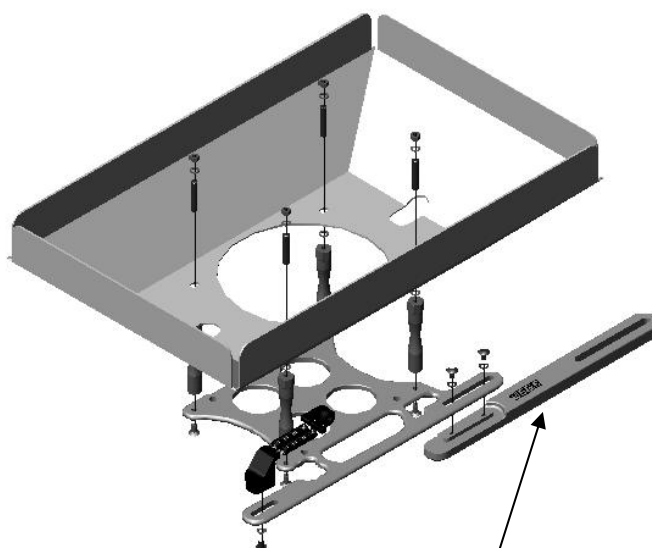
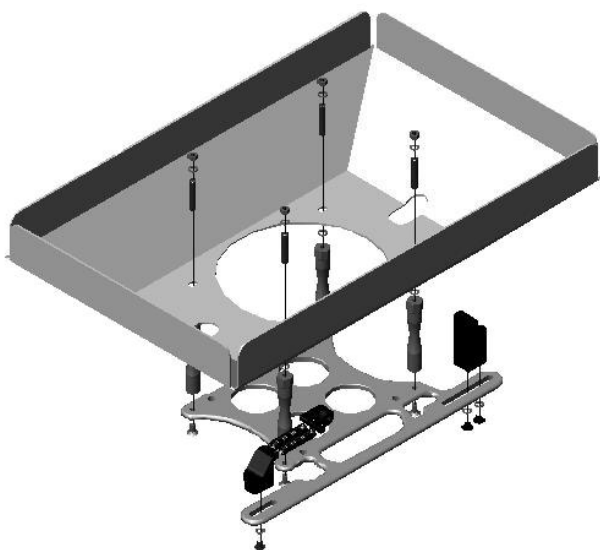

Throttle Stop Bracket  
#555-55016 (Not Included),  
Installed as shown.



1-800-345-4545 [jegs.com](http://jegs.com)