

## **Installation Instructions for 15030 to 15038, 15040 to 15043, 15060 to 15068**

### **Billet Fuel Filter**

Available in: -06AN, -08AN, 3/8" Barb, 3/8"NPT and 5/8"-18 Inverted Flare.

**BE CAREFUL – DO NOT OVERTIGHTEN THE THREADED FITTINGS!**

#### **WARNING!**

Check for leaks before starting your vehicle. Take precautions when working with gasoline – It is a fire hazard and is potentially explosive.

#### **Replacement Filter Element & O-Ring Kit (JEG'S part #555-15045) Instructions:**

1. Place the filter element down into the body of the billet fuel filter, making sure the filter seats flat.
2. Slide rubber o-ring into the o-ring groove.
3. Using assembly lube or equal product applied to the o-ring, screw the fuel filter together and snug tight with a -08AN wrench (JEG'S part #555-80552).

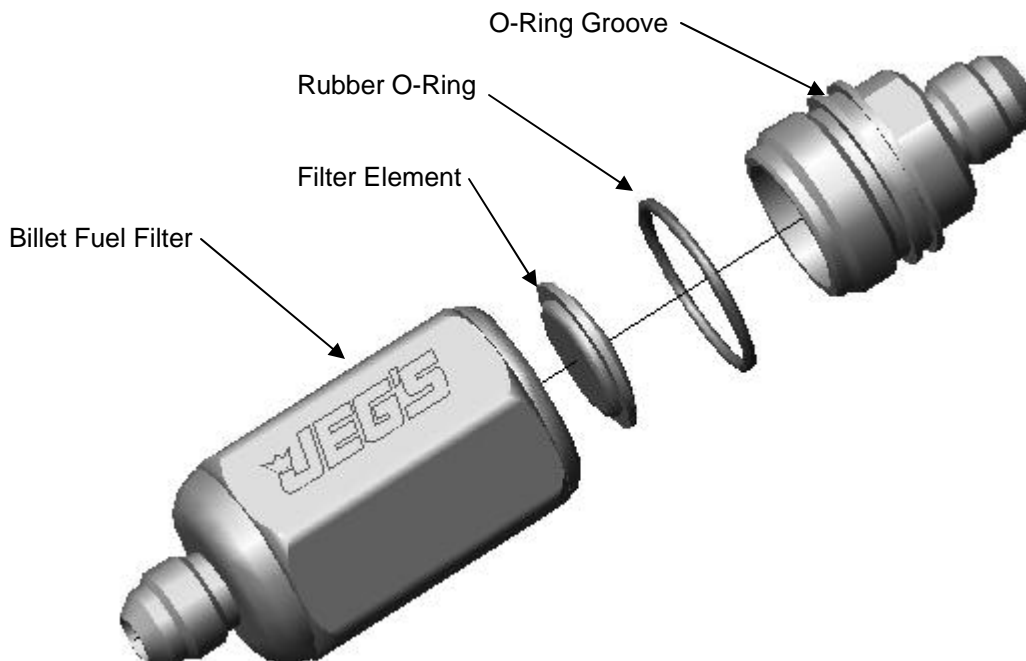

1-800-345-4545 [jegs.com](http://jegs.com)