

Installation Instructions for 30571 2-1/2" Header Dual Kit w/o Mufflers

This kit fits '64-'68 Mustang 289, 302, '69 Mustang 390, '69-'73 Mustang 289, 302, 351, '67-'68 Cougar 289, 302, 351, 390, 427, '70-'73 Cougar 351, 390, 400--all equipped specifically with long tube (Small Block) headers JEGS # 555-30070 and 555-300130, or Flowtech # 387-32102 and 387-12102.

NOTE: This kit is designed for use specifically with long tube JEGS or Flowtech headers. Modifications will be necessary to the front collector pipes when using with other header designs.

NOTE: The headers and mufflers are not included in this kit.

Danger Warning: Should the purchaser decide to install this exhaust product at home, be warned that pleasure car or light duty truck "bumper" jacks are intended for emergency use only. The use of frame contact jack stands in conjunction with a floor jack as main support is highly recommended to minimize accidental dropping of a vehicle while the installation proceeds.

Hardware kit:

- | | | |
|---------------------------------|--|------------------------------------|
| 4) 5/16" lock washers | 2) BR755 L-Bracket | 2) BR104 rubber hanger |
| 2) BR92256 block hanger | 4) 2-1/2" standard clamps | 6) 3/8" lock washers # 33622 |
| 2) fender washers # 33219 | 6) 5/16" X 1" lag screws | 4) 5/16" nuts # 36104 |
| 2) 5/16" x 1-1/2" bolts # 10059 | 6) 3/8" nuts # 36106 | 2) F33 flanges |
| 6) 3/8" X 1-1/4" bolts # 10107 | 2) #MP48005 3" collector gaskets | 1) # 2683 left 2-1/2" hanger clamp |
| 2) 5/16" x 1 bolt # 10055 | 1) #2682 right 2-1/2" hanger clamp | 6) #A25AF 2-1/2" accusal clamp |
| 2) # 2681 hanger brackets | 2) 7/16" fine thread flange nuts # 37373 | |

Tube kit:

- | | |
|---|---|
| 1) left collector pipe # 8158781 | 1) right collector pipe # 8158782 |
| 1) right front extension pipe # 8158784 | 1) left tail pipe # 8158785 |
| 1) right tail pipe #8158786 | 2) left & right tail pipe S-bend extension # 8158787 |
| 1) left front extension pipe # 8158783 | 2) left & right tail pipe turn down extension # 8158788 |

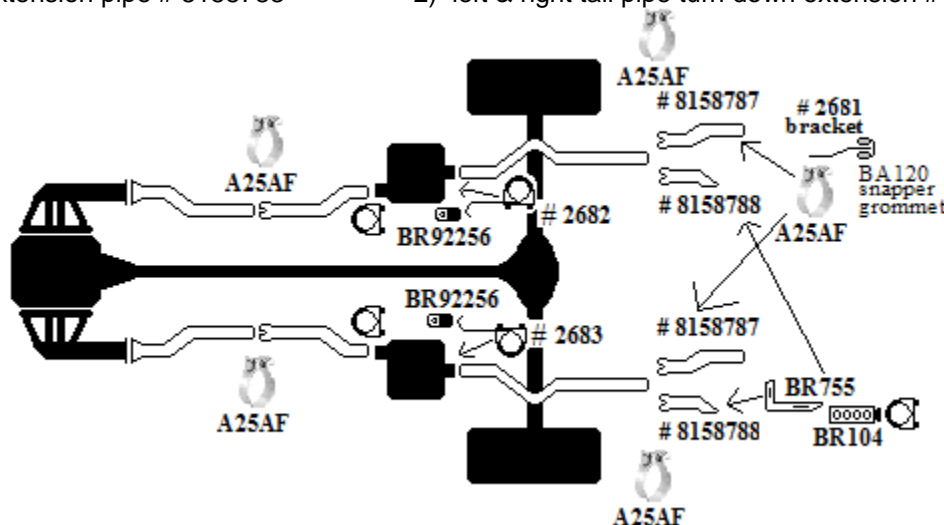

Limitation of liability--disclaimers: The regulation of emissions production, noise levels, and safety standards is undertaken by the federal government, each of the 50 state legislatures, and by many local municipalities, towns and counties.

The manufacturer of this product makes no warranties of merchantability, of fitness for a particular purpose, or that its products are approved for general use, or that its products comply with laws, regulations or ordinances in the states where they may be sold to the ultimate purchaser, the consumer.

The entire risk as to the conformity of this product in any such state as to repair, should the product prove to be defective or non-conforming to local laws, is on the retail purchaser, the buyer, the ultimate consumer, of such product and it is not upon the seller, distributor, or manufacturer.

In this connection, the retail purchaser, the buyer, the ultimate consumer assumes the burden of the entire cost of any and all necessary service, alterations, and or repair.

The foregoing statement limits the liability of the manufacturer.

California vehicle code section 27156 prohibits the advertising, offering for sale, or installation of any device which modifies a vehicle's emissions control system. This product is therefore not legal for sale or use in California on vehicles originally equipped with catalytic converters.



1-800-345-4545 jeps.com

Installation Instructions:

NOTE: Do not tighten any clamps until the last step.

1. If you will be raising up the vehicle for installation, do so in a safe manner on a flat, level surface, and using frame contact stands. Remove the old exhaust system and the original hangers.
2. Install the left # 8158781 and right # 8158782 collector pipes to the header collectors using the mp48005 gaskets and f33 flanges, and using the included 3/8" hardware. Tighten only enough to hold in place.

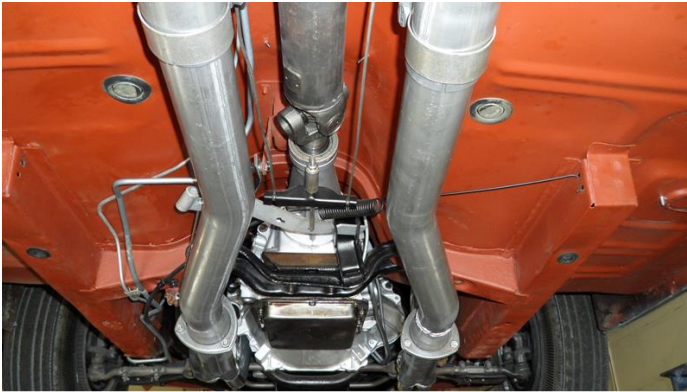

3. Install the ID end of the left # 8158783 and right # 8158784 front extension pipes to the collector pipes using the # A25AF 2-1/2" Accuseal clamps. Be sure to leave adequate clearance between the floor boards and the drive shaft.
4. Install the mufflers (offset in towards the driveshaft, center out) onto the front extension pipes using standard 2-1/2" muffler clamps. Rotate the front extension pipes to clear the driveshaft and the body.



5. On most vehicles there is a seat belt bracket/bolt that is on the rear floor seat pan. The bolt is a 7/16" fine thread. Attach the br92256 block hanger to this bolt using a 7/16" fine thread nut. You will be using the left 2683 and right 2684 hanger clamps to connect the outlet of the mufflers and the inlets of the tail pipes together, and the wire portions of the hangers to the br92256 block hangers above. If you do not have a seat belt bracket, you will need to drill two holes 1/4" holes above and in towards the drive shaft (see picture below) and use 5/16" lag screws, two per hanger, to mount the br92256 block hangers.
6. Install the left and right tail pipes to the outlets of the mufflers. On the driver side attach the tail pipe to the muffler using the 2683 hanger clamp and on the passenger side use the 2684 hanger clamp. Attach the wire portion of the hanger clamps to the br92256 block hangers above.

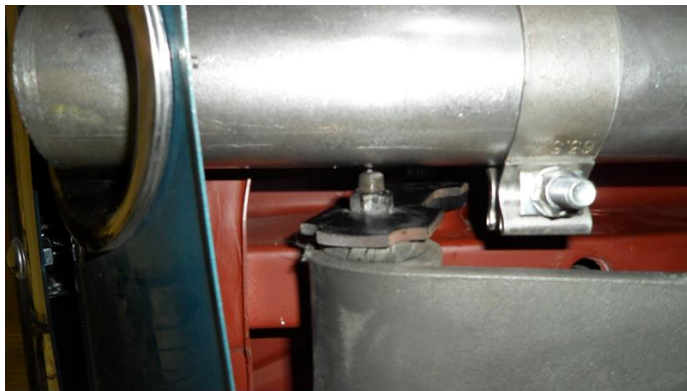

7. There are two options for the tail pipe exit. For those with the exhaust valence, we recommend using the 8158787 s-bend extension pipes. We also include turndowns # 8158788 for those without the valence. For the s-bend extensions, on the passenger side, there is a hole above for which to mount the # 2681 hanger bracket with # ba120 snapper grommet, using a 5/16" x 1-1/2" bolt, nut, and lock washer. On the driver side, you may need to drill an identical hole to mount this same hanger setup. Mount the hangers, attach the s-bend extensions to the tail pipes using 2-1/2" accuseal clamps, and connect to the s-bend extensions to the 2681 hanger brackets using the remaining 2-1/2" accuseal clamps.



8. For those using the turndowns, locate a spot in the frame to install a hanger setup using the br755 L-bracket and br104 rubber hanger. Use an existing hole in the frame or drill a 1/4" hole in the frame and use the remaining 5/16" lag screws to mount the hanger setup to the frame. Use the remaining 5/16" x 1" bolt and hardware to connect the br755 L-bracket and br104 rubber hanger. Attach the hook of the br104 to the tail pipe or turndown below using the remaining standard 2-1/2" muffler clamp.
9. Make sure that all the parts of the system are clear of all frame members, all hoses, suspension members, and brake and fuel lines. Starting at the collector pipes, tighten all connections and nuts and bolts. Make sure all parts are clear and will not leak or rattle. After several days of driving retighten all bolts. The Accuseal clamps should be torqued to about 40 ft/lbs.



1-800-345-4545 jeps.com