

# **Installation Instructions for 60765 & 60766 Steering Column Kit**

**WARNING!** This kit requires that all components be GTAW (TIG) process welded by a certified welder.

## **Installation Instructions:**

**NOTE:** Be sure to clean the steering column shafts at each end with sand paper prior to assembly to remove any oil or dirt before welding.

1. Insert the splined steering hub adapter into the quick release steering hub and bolt this assembly to your steering wheel.
2. With the driver seated in the vehicle, in race position, measure for proper placement of the steering shaft. This is done as follows:
  - a. With driver holding the steering wheel/quick release hub assembly in the proper position, measure vertically from the floor of the vehicle to the center of the steering hub adapter.
  - b. Next, measure horizontally from the firewall to the center of the steering hub adapter. This will give the coordinates for the steering wheel position. (See FIGURE 1)
3. Press the supplied u-joint over one end of the upper steering shaft. This end goes through the firewall.
4. Slide the stop collar over the upper steering shaft until it touches the u-joint. Do not tighten at this time.
5. Support the length of the upper steering shaft so that the steering wheel end is held at the dimension determined previously and is centered with the driver's seat.
6. Raise or lower the opposite end of the shaft to achieve the desired steering wheel angle. Support the end of the shaft in this position.
7. Mark the position where the lower end of the shaft meets the firewall. Cut a hole in the firewall to allow the shaft to slide through. It is better to make a large hole to allow for adjustment and make a patch panel to fit around the shaft, than to make a small hole and risk tearing the firewall sheetmetal.
8. Slide the u-joint end of the shaft through the firewall hole. Support the shaft in place with wire from the roll cage and dash bar at the correct dimension.
9. Install your steering box u-joint (not included) onto the steering box shaft. Measure the distance between the steering box u-joint and the steering shaft u-joint. Remember to account for the depth of the u-joint socket.
10. Cut the steering box shaft to the distance just measured. Trial fit the piece in place.
11. Check for adequate header and chassis clearance. Move the shaft assembly as necessary to achieve clearance. Remember to keep the upper shaft centered to the driver's seat.
12. With the upper steering shaft angle set, cut the aluminum column tube to length so that it mounts 1" from the firewall and 2" from the steering wheel end of the shaft.
13. Install the nylon bushings into the ends of the aluminum column tube.
14. Slide the column assembly over the upper steering shaft. At this time, you may trim the steering shaft if it is too long.
15. Tack weld the u-joints to the steering shafts.
16. With the splined steering hub adapter inserted into the quick release steering hub, slide the steering wheel assembly onto the upper steering shaft. Determine the desired orientation of the steering wheel and reference mark the upper steering shaft and splined steering hub adapter.
17. Remove the steering column assembly from the vehicle and weld u-joints complete. Slide the splined steering hub adapter ONLY onto the upper steering shaft making sure to line-up the reference marks made in step 16 and weld complete as shown in FIGURE 3. **DO NOT REMOVE THE COLUMN TUBE FROM THE SHAFT DURING WELDING!**
18. After the welds have cooled, re-install the shaft assembly in the vehicle. Mount the column in place using JEGS #555-60769 steering column mount kit.
19. Slide the stop collar up so that it is 1/2" from the bottom nylon steering bushing. Tighten the set bolt. This collar will help prevent the steering column shaft from sliding into the driver's compartment in case of impact.
20. Install the steering wheel and adjust the tie rods from the mounting kit to center the steering wheel.



**1-800-345-4545 [jegs.com](http://jegs.com)**

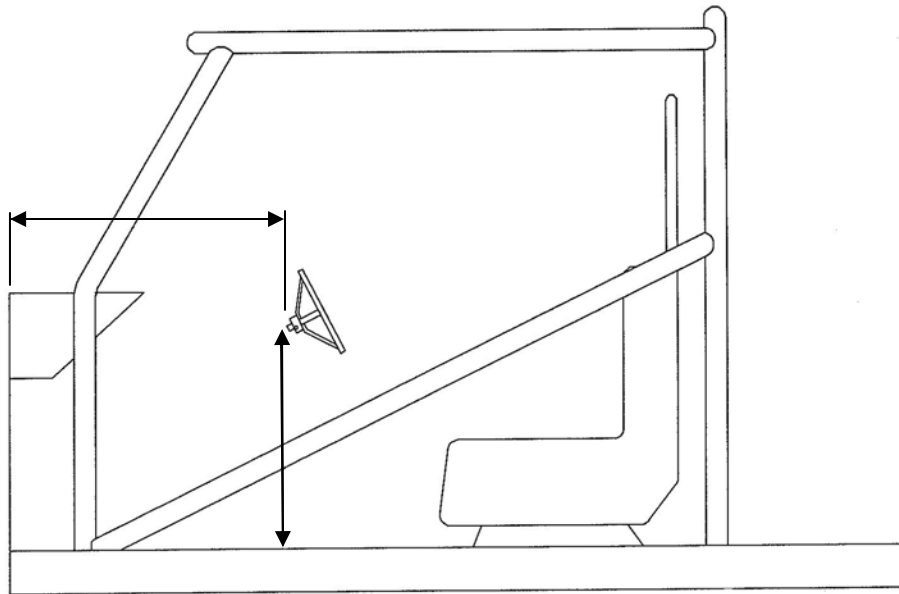

**FIGURE 1**

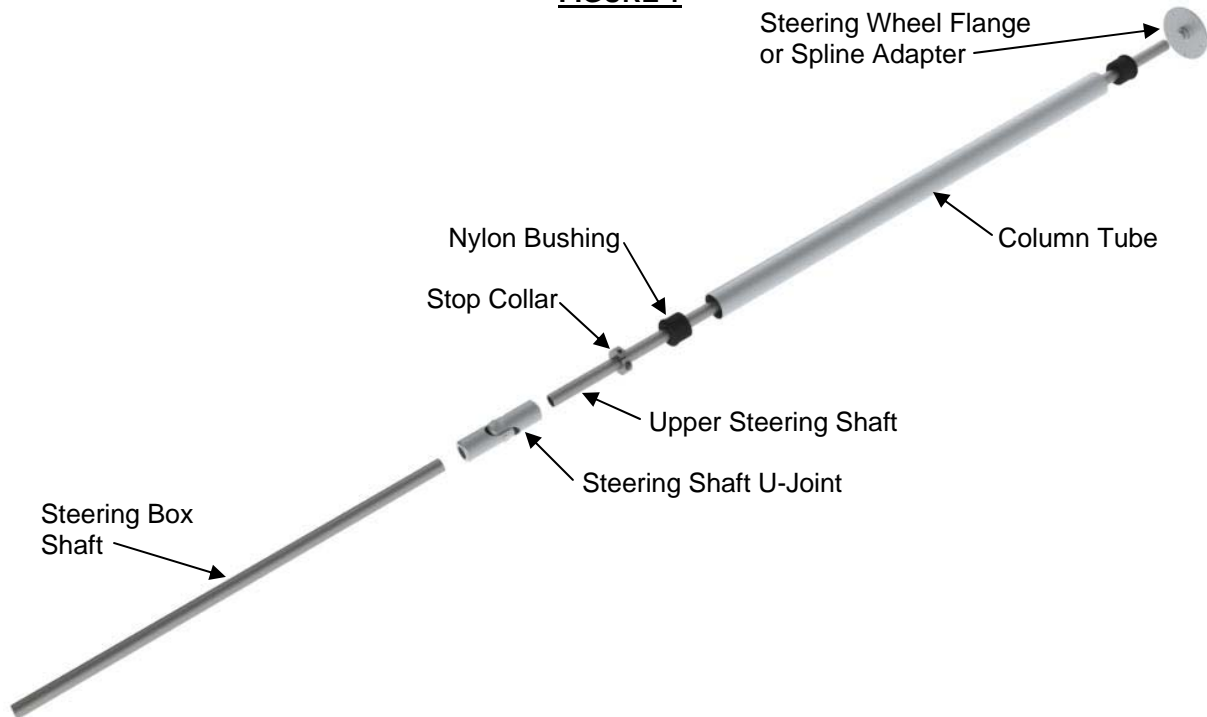

**FIGURE 2**

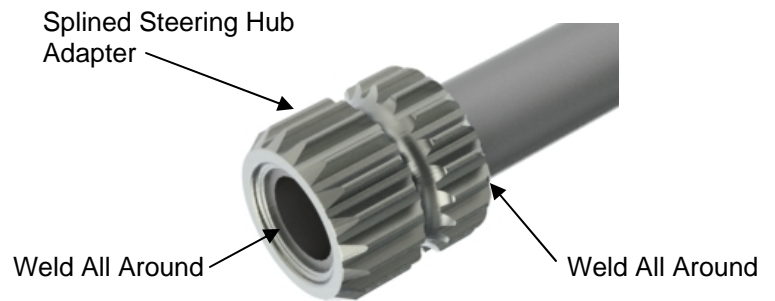

**FIGURE 3**