

# Installation Instructions for 82270 & 82271 Hood and Deck Lid

1. Always test fit the hood or deck lid while checking for any fitment issues. Some notching or removal of the bracing in the cowl, fan shroud, fender, radiator and windshield wiper areas may be required. Keep in mind that most fiberglass hoods and deck lids are manufactured with a 1/2" - 3/4" lip along the outer edges for rigidity during the transportation process in order to maintain their original form and minimize any damage or distortion. However, we recommend that you trim this lip down to approximately 1/4" before beginning the installation. This can be achieved by using 1/4" masking tape to create a guide for trimming with a fine blade in a saber saw.
2. Figure 1 indicates the recommended locations for the 90 degree mounting plates. Some vehicles may require different positioning based on vehicle design. Keep in mind that you want to eliminate air from entering under the front edge and lifting the panel, which in some instances could cause breakage, impaired vision and serious safety concerns at speed.
3. Once you determine the best location for the 90 degree mounting plates, begin the installation at the corners first. Mount the plates approximately 1/8" below the fender line as most fiberglass hoods and deck lids are 1/8" thick as indicated in Figure 2. The mounting plates are installed with the steel pop rivets supplied in the kit.
4. Set the hood or deck lid on top of the fastener plates. Align or center the panel and tape down securely. It should set approximately 1/8" above the fenders at this point. Mark the edges of the hood or deck lid where the mounting plates touch the bottom lip of the hood. Remove the hood and notch the lip to just outside of your markings and remove the excess lip between the marks (over the mounting plates) to just flush below the panel. See Figure 3.
5. Re-set the hood or deck lid on top of the fastener plates to double check the fitment. You can bend the mounting plates up or down a little to achieve a flush panel fit. In some cases you may have to relocate the brackets. By doing so you will achieve the most aerodynamic position and the best possible visual look. Remove the panel and install the remainder of the brackets as discussed in steps 3, 4 & 5. Remember to install the brackets at the front center of the panel to further minimize panel lift as described in step 2.
6. Once all of the brackets are installed, the panel is notched and the proper height of the bracket is achieved you are ready to begin installation of the springs. The orientation of the spring allows you to index the button slot of the fastener to multiple positions. You should test fit the fastener in the bracket to arrive at the proper orientation of the button slot as it relates to the position of the spring. Attach the springs to the bottom of the brackets with the steel pop rivets supplied in the kit from the top through the mounting plate.
7. To begin the installation of the fasteners place the hood or deck lid over the mounting plates, center the panel and tape down securely. At each corner mount measure out 1-1/16" from the edge of the fender to the center of the mounting plate. Drill a 1/8" pilot hole through the panel and check to make sure that you are lined up with the center of the fastener hole. Drill the pilot hole out to 5/8" and then use a 7/8" counter sink to chamfer the hole. Insert the fastener and check for fitment. **Do not drill and mount the fastener plates to the panel at this time.** Repeat this step at all four corners of the panel. Then repeat this step at each fastener between each corner until all of the fasteners are properly fitted.
8. Orient the fastener plate to the desired position and drill the 1/8" holes for retention to the panel. **Do not rivet the fasteners onto the panel until after the panel has been painted and is ready for use.** After the panel is painted, use the aluminum rivets to secure the fasteners to the panel. Gently flatten the underside of the rivet with a small punch and a smooth with a file.

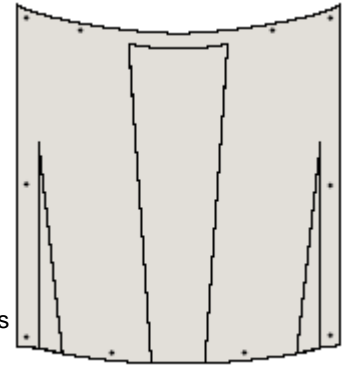

Figure 1

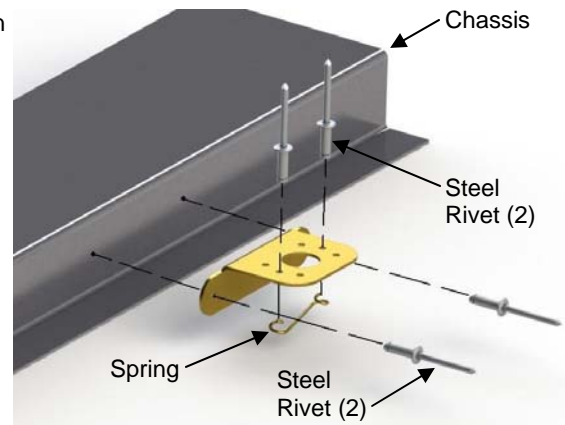

Figure 2

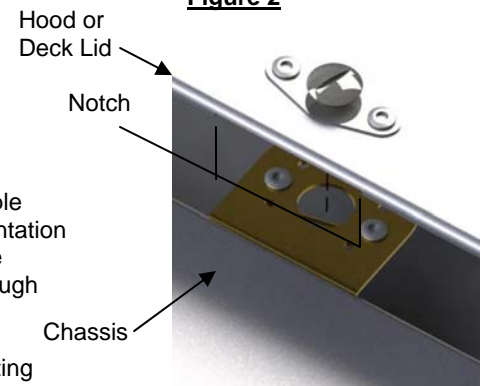

Figure 3

