



COLD AIR SYSTEM

Installation Instructions for:
Part Number 21-402
1990 – 1993 Acura Integra

ADVANCED ENGINE MANAGEMENT INC.
2205 126TH Street, Unit A Hawthorne, CA. 90250
Phone: (310) 484-2322 Fax: (310) 484-0152
www.aempower.com
Instruction Part Number: 10-205
1990-1993 Acura Integra B17A1 & B18A1 C.A.R.B. E.O. #D-392-5
© 1998 Advanced Engine Management, Inc.

Congratulations! You have just purchased the finest Air Induction & Filtration system for your car at any price!

The **AEM** Cold Air System is the result of extensive development on a wide variety of cars. Each system is engineered for the particular application. The **AEM** Cold Air System differs from all others in several ways. We take the inlet air from outside of the engine compartment where the inlet air is considerably cooler than the hot underhood air. The cooler inlet air temperature translates to more power during the combustion process because cool air is denser than warm air. **AEM** has conducted extensive inlet air temperature studies and we have seen temperature reductions of up to 50 degrees by pulling air from outside of the engine compartment. The air mass flow to the engine is increased because of the increased airflow *and* reduced inlet temperature, which translates to more power. The **AEM** Cold Air Systems are **50 states Street Legal** and come with complete instructions for ease of installation.

Our system is constructed of lightweight aluminum and then painted with a zirconia based powder coat for superior heat insulating characteristics. The aluminum will not crack in extended use like plastic and it is actually lighter than plastic. The tube diameter and length are matched for each engine to give power over a broad rpm range. Unlike the plastic systems that use a continually diverging cross section, we take advantage of the acoustical energy in the duct to promote cylinder filling during the intake valve-opening event.

Our Dyno testing as well as **independent dyno tests** (see 7/97 Sport Compact Car Magazine) prove that the **AEM** Cold Air System produces as much as twice the power gain than any other system on the market.

Bill of Materials

<u>QTY</u>	<u>PART #</u>	<u>DESCRIPTION</u>
1	2-438	Inlet Pipe
1	21-202	2.75" AEM Air Filter & Clamp
1	444.460.04	6mm Nut
1	559999	6mm X 25mm X 1mm Washer
1	1228599	Rubber Mount
1	5-275	2.75" x 3" Connector Hose
2	103-BLO-4420	2.75" Hose Clamp
12"	65128	3/8" Breather Hose
16"	516-006	5/16" Water Hose
4	4093-5	3/4" Hose Clamp
2	784631	1/8" Rubber Grommet
2	8-103	1/8" Nylon Straight Connector
1	784630	1/4" Rubber Bumper
1	10-205	Instructions
2	10-922S	Regular AEM Inc. Sticker
1	10-400W	White License Plate Frame
1	10-905	Warning Decal
1	10-402	E.O. Decal

Read and understand these instructions BEFORE attempting to install this product.

1) Getting started

- a) Make sure vehicle is parked on a level surface.
- b) Set parking brake.
- c) Disconnect negative battery terminal.
- d) If engine has run within the past two hours let it cool down.

2) Removing the stock air inlet system

- a) Remove the stock air box assembly and attaching hardware from inside the fender well.
- b) Disconnect breather hose from the air inlet tube.
- c) Disconnect the water bypass hose from throttle body or the fast idle thermo valve, where equipped, located at the lower portion of the throttle body. Disconnect the opposite side of the water bypass hose, which runs to either the intake manifold or the water outlet neck. Remove the entire water bypass hose and breather hose assembly from the vehicle.
- d) Loosen and remove the air inlet tube from the throttle body.
- e) Jack the front of the vehicle and support using properly rated jack stands.
 - i) Remove the lower front splashguard.
 - ii) Remove the front right tire and remove the inside splashguard (inner fender liner).
- f) Remove the resonator from underneath the vehicle.

3) Installing the cold air system

- a) The inlet pipe for this system includes an inlet pipe and the turbo-flo air filter.
- b) Install one orange connector hose on the throttle body end of the inlet pipe. That is the end closest to the breather nipple.
 - i) Install two hose clamps on the connector hose and just snug them down on the hose.
- c) Install another connector hose on the end of the inlet pipe. Secure hose clamps on the hoses and snug them down sufficiently so that you can still adjust the position of the pipe when it is installed.
 - i) Install the inlet pipe by inserting one end into the hole exposed by the removal of the OE air inlet resonator.
 - ii) The support tab on the inlet pipe will line up with a threaded hole on the inner fender well. Install the rubber isolator mount and attach the air inlet tube onto the rubber mount. Install the large fender washer and the lock nut onto the isolator mount stud and snug it down. **Failure to install the rubber mount will void all warranties of the Cold Air System.** Below is a diagram of how the rubber mount should be installed.

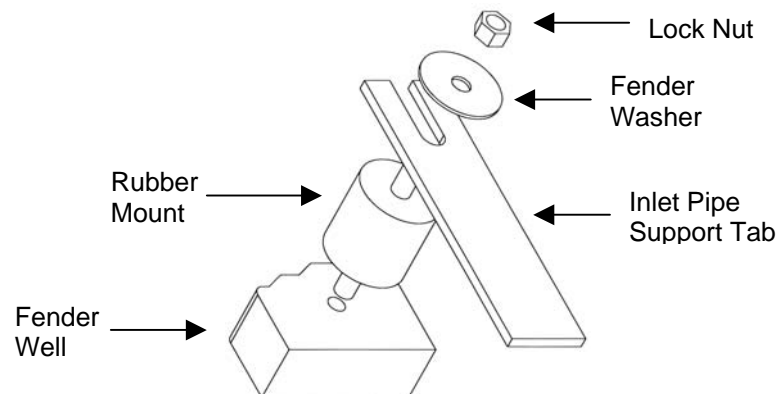

- iii) At this point you should be able to align the inlet pipe such that:
 - (1) The connection to the throttle body is not twisted.
 - (2) The rubber isolator mount is not under excessive stress as to lead to premature failure.
 - (3) Make sure inlet pipe is free from hitting all wires and brackets in the vehicle.

- (4) The end of the inlet pipe should be centered in the hole which was exposed by the removal of the OE air inlet resonator.
- iv) Tighten all hose clamps and the rubber isolator mount properly.
- d) Install the **AEM** filter on to the end of the inlet tube. Push the filter on around 2 inches over the inlet pipe and install one hose clamp to secure the filter on to the inlet pipe. Once fitment is checked, you can either push the filter on to the inlet pipe more or less depending on clearances. Tighten the hose clamp after this is done.
- e) Connect the breather hose to the inlet tube using the black connector hose and two clamps supplied with the kit.
- f) Connect the new supplied water bypass hose and clamps to the throttle body or the fast idle thermo valve, where equipped, and either the intake manifold or the water outlet neck disconnected earlier.
- g) Included in the kit are two rubber grommets, two straight connectors and one rubber bumper. Some vehicles need to use both grommets and some only need one.
 - 1) Both automatic and manual transmission models have a throttle valve dashpot control diaphragm. There is a vacuum line that goes between air inlet tube and the throttle valve dashpot control valve diaphragm. During the installation of the AEM Cold Air System this vacuum line needs to be reconnected to the inlet pipe. Install a rubber grommet into the exposed hole in the inlet pipe and insert a straight connector through the grommet. Install vacuum line over the straight connector.
 - 2) Automatic models have a starting air valve. The starting air valve has a vacuum line that runs from it to the air inlet tube. During the installation of the AEM Cold Air System this vacuum line needs to be reconnected to the inlet pipe. Install a rubber grommet into the exposed hole in the inlet pipe and insert a straight connector through the grommet. Install vacuum line over the straight connector.
 - 3) If your vehicle does not have both the throttle valve dashpot and the starting air valve then install the rubber bumper into the exposed hole left over.

4) Re-assemble the vehicle

- a) Install the right fender liner and the lower front splashguard. ***Failure to install the plastic splashguard will result in diminished performance and increase the potential for engine damage due to water ingestion in rainy conditions.***
- b) Install the front right wheel and lower the vehicle.
- c) Inspect the engine bay for any loose tools and check that all fasteners that were moved or removed are properly tight.
- d) Start engine and perform a final inspection before driving the vehicle.

For technical inquiries please E-Mail us at: tech@aempower.com