

DIRECTION 191

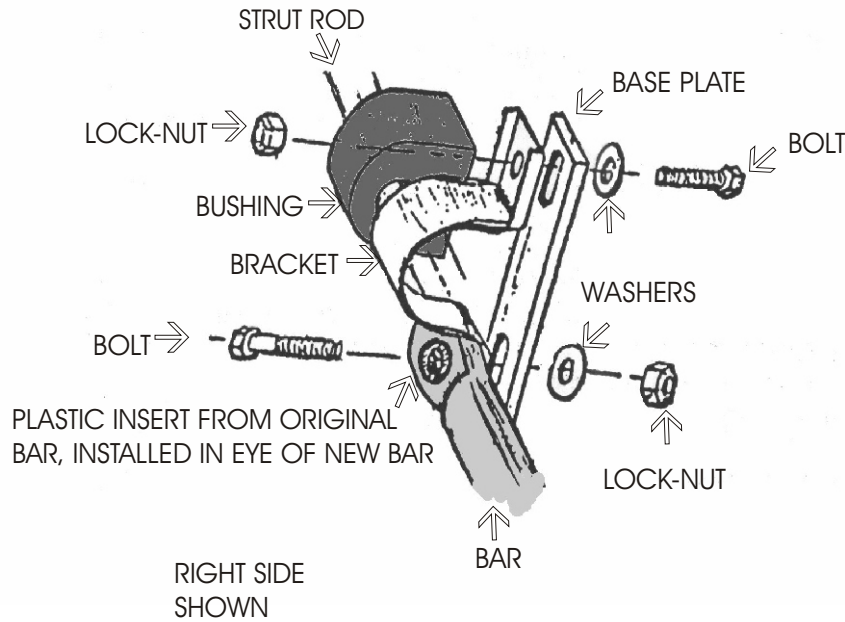

Direction #191

NOTE: This bar was designed as an O.E. replacement bar. It may come with none, some, or all of the hardware required to install it, depending on the application. If hardware is not included with the kit, the hardware from the O.E. bar must be retained and re-used if in good condition or replaced with new parts if not suitable for re-use. O.E. hardware not included with this kit must be obtained from an O.E. parts dealer. If your car was not equipped with an O.E. bar, the installation of this bar may not be possible.

STEP #1. Remove the O.E. bar and retain the O.E. attaching hardware. On some applications, if the suspension is allowed to hang, the bar will be more difficult to remove because of binding in the suspension.

STEP #2. This bar may differ slightly from the O.E. bar, but it was designed to fit in the same position. Install the new bar in the same position as the O.E. bar, using the O.E. hardware and/or supplied hardware if provided.

STEP #4. After the installation is complete, check for clearance of all parts throughout the suspension travel distance.

STEP #5. Road-test the vehicle to familiarize yourself with its new handling. As we cannot supervise your installation or your driving, we cannot be held responsible for more than the cost of the kit. For best balance and control, this kit should be used with our rear bar. Contact your dealer for information.

NOTE: Plastic inserts from your original bar must be retained for use in the new bar. Slight modifications may be required to make these inserts fit the bar. If they need to be replaced, contact your Honda dealer.

HARDWARE

2	RH 053	Brackets	2	RH 031	Base Plates
2	RH 214	Bolts	2	RH 226	Bolts
4	RH 304	Lock-Nuts	4	RH 104	Flat Washers
2	RH 510	Bushings	2	RH 042B	Frame Brackets
2	UB 612B	Urethane Bushings			