

DIRECTION 284

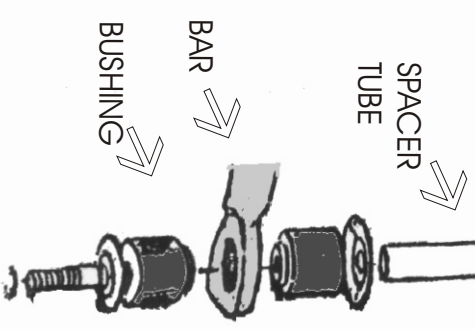
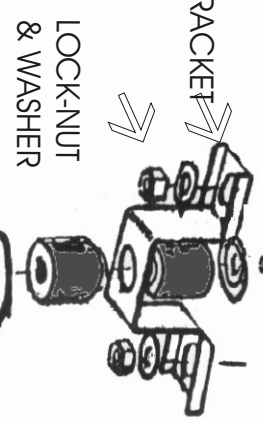
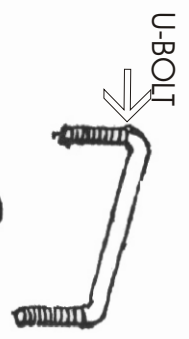
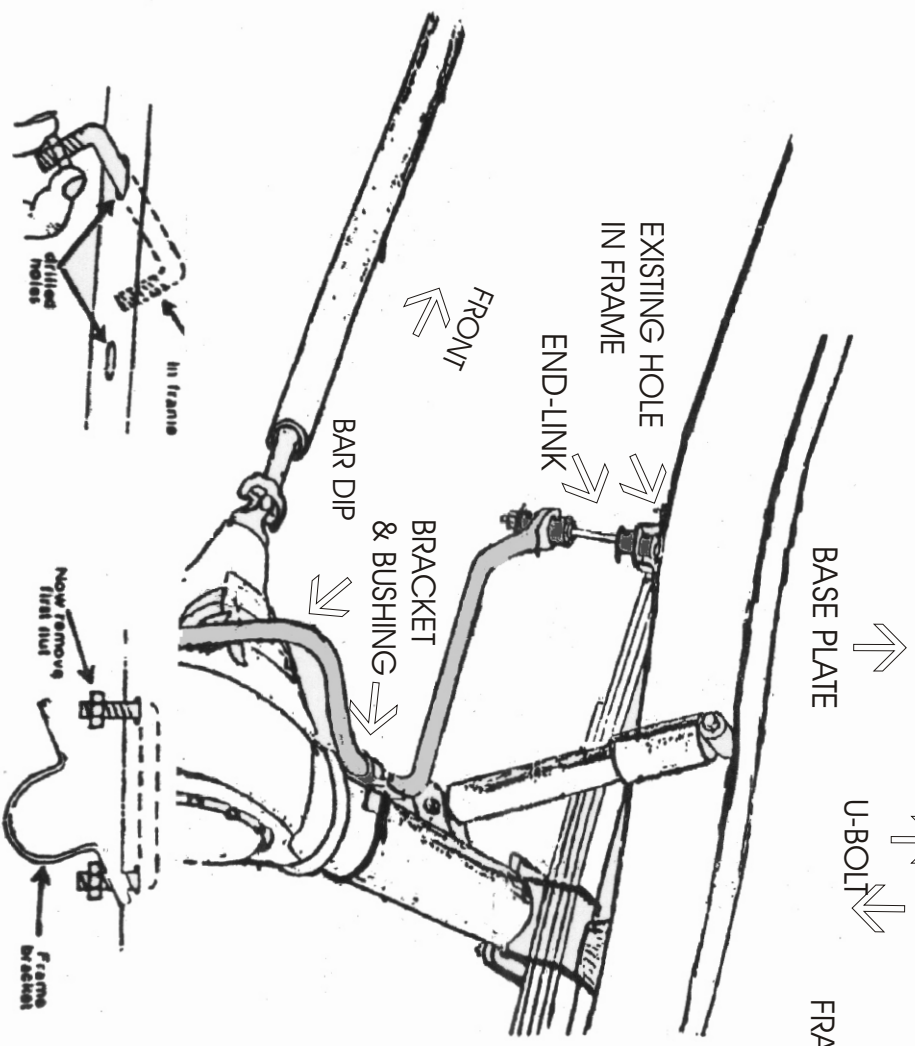
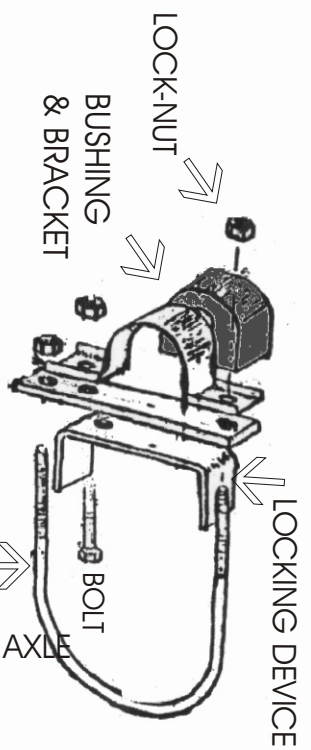

END-LINK ASSEMBLY

Direction 284

- Step #1. Assemble end-links as shown so as to connect bar eye and the frame bracket. The bolt should be passed from inside the bracket so that the head is up.
- Step #2. Lay the bar on the front of the axle dip up, with arms forward and inboard the shock absorbers.
- Step #3. Place the D-shaped bushings on the bar mid-section (they may be cut on the side to facilitate this), near the shoulder bend. Behind it, place the plate with slotted holes and then the locking device. Around the bushing, place the bar bracket. Pass the legs of the U-bolt from behind, through the bracket holes. Place flat washers on them and start the lock-nuts. The bar should now be located on the forward-top side of the axle. Note: The U-bolt must be passed under the brake line so as not to crush it.
- Step #4. Raise the bar arms up to the bottom of the frame. The forward bracket hole should locate on an existing hole. Mark the frame bottom of the other bracket hole. Drill with a 3/8" drill bit.
- Step #5. Place a lock-nut on one leg of the square U-bolt. Insert the other end into the hole in the frame bottom and maneuver it until the leg drops out of the drilled hole. Secure the frame bracket with the lock-nuts provided.
- Step #6. Have someone bounce the rear of the truck so that you may check the movement of all parts so as to be sure they will all clear throughout the suspension travel distance.
- Step #7. Road test the vehicle to familiarize yourself with its new handling. As we cannot supervise your installation or driving, we cannot be responsible for more than the cost of the kit.

Note: This kit should be used in conjunction with our front kit for best control, handling and steady tracking on the highway.

HARDWARE

| | | | |
|----------|----------|----|------------------|
| 2 RH 041 | Brackets | 2 | RH 016 End-Links |
| 2 RH 410 | U-Bolts | 2 | RH 052 Brackets |
| 2 RH 600 | Plates | 2 | RH 040 Brackets |
| 2 RH 511 | Bushings | 2 | RH 402 U-Bolts |
| 2 RH 214 | Bolts | 10 | RH 304 Lock-Nuts |
| 6 RH 104 | Washers | | |