

Kit No. 57125

Please read these instructions completely before proceeding with installation

Air Spring Kit Parts List

Item	Description	Quantity
A	Air Springs	2
B1	Upper Bracket - Left Hand	1
B2	Upper Bracket - Right Hand	1
C	Elbow Fitting	2
D	Lower Brackets	2
E	Heat Shield Kit	1

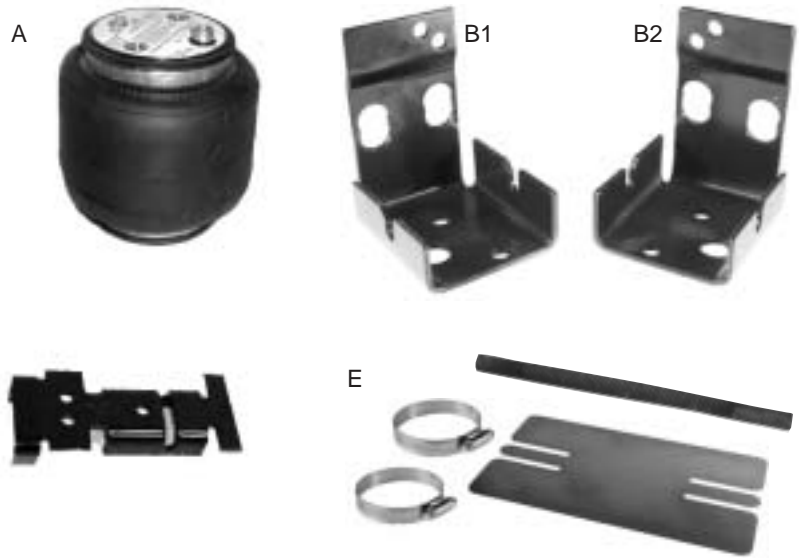

Bracket Attaching Hardware

Item	Description	Quantity
F	3/8" Nut (fine)	2
G	3/8" x 6" U-Bolts	2
H	Saddle Clamps	2
I	5/16" x 1" Hex Head Cap Screws	2
J	5/16" Nuts	2
K	3/8" Nuts (coarse)	4
L	Flat Washers	10

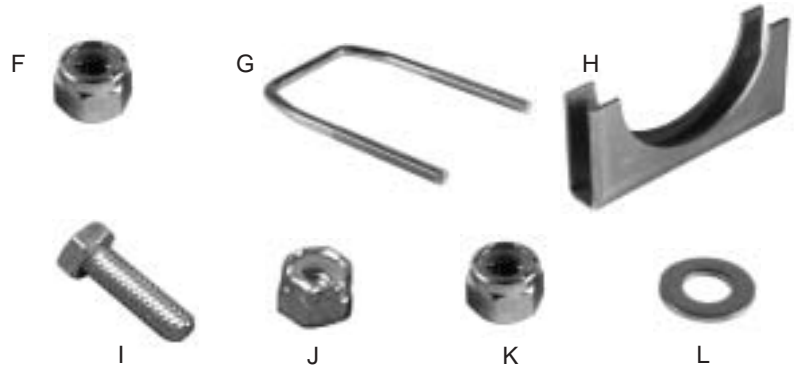

Air Spring Attaching Hardware

Item	Description	Quantity
M	3/8" Stud	2
N	3/8" x 7/8" Hex Head Bolts	6
O	Lock Washers	6



Air Line Assembly Parts List

Item	Description	Quantity
AA	Air Line Assembly	1
BB	Tie Strap	6
CC	Valve Caps	2
DD	5/16" Flat Washer	2
EE	Rubber Washer	2
FF	Star Washer	2
GG	5/16" Hex Nut	4

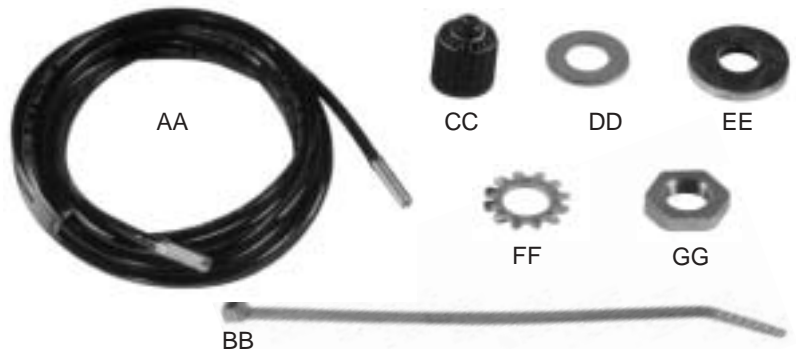

Tools Needed

$\frac{7}{16}$ ", $\frac{9}{16}$ " open-end or box wrenches

Crescent Wrench

Ratchet with $\frac{3}{8}$ ", $\frac{9}{16}$ " and $\frac{1}{2}$ " deep well sockets

$\frac{3}{8}$ " and $\frac{5}{16}$ " drill bits (very sharp)

$\frac{3}{8}$ " Nut Driver

Heavy Duty Drill

Torque Wrench

Hose Cutter, Razor Blade, or Sharp Knife

Hoist or Floor Jacks

Safety Stands

Safety Glasses

Air Compressor, or Compressed Air Source

Spray Bottle with Dish Soap/Water Solution

IMPORTANT: Your vehicle may be equipped with a rear brake proportioning valve. Any type of load assist product could affect brake performance. We recommend that you check with your dealer before installing this type of product. If your vehicle **DOES NOT** have a rear brake proportioning valve or is equipped with an anti-lock type brake system, installation of a load assist product will have **NO EFFECT ON BRAKE SYSTEM PERFORMANCE**.

DANGER: Compressed air can cause injury and damage to the vehicle and parts if it is not handled properly. For your safety, do not try to inflate the air springs until they have been properly secured to the vehicle.



Figure 1

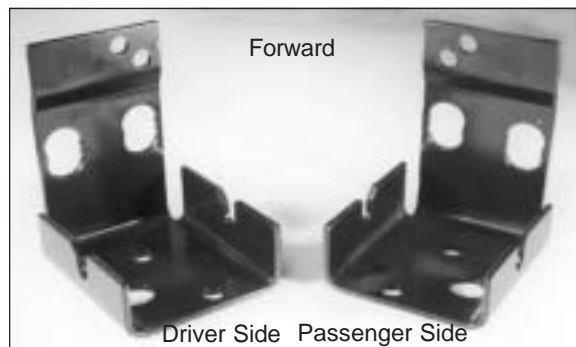

Figure 2

I. Getting Started

1. Determine the Normal Ride Height. The Normal Ride Height is the distance between the bottom edge of the wheel-well and the center of the hub with the vehicle in the "as delivered" condition. In some cases, Normal Ride Height is not perfectly level.
 - a. Remove unusual loads and examine your vehicle from the side to ensure it is on a level surface.
 - b. If necessary (in cases where your leaf springs are sagging badly), use a jack to raise the rear end so that the vehicle achieves the original "as delivered" ride height.
2. Measure the distance between the center of the hub and the bottom edge of the wheel well (see Figure 1). This is the Normal Ride Height. Enter the measurement below:

NORMAL

RIDE HEIGHT: _____ inches

II. Assembling the Air Spring Unit

1. The upper brackets are designated "Left" and "Right" indicated by "L" or "R" on the bracket. "L" for the driver side and "R" for the passenger side (Figure 2).

2. Install 90 degree air swivel fitting to the top of the air spring. Tighten 1 and 1/2 turns.

3. Align the right hand upper bracket (B2) with the mounting holes in the air spring and install the 3/8" stud (M) in the outboard tapped hole with the short threaded portion into the air spring (Figure 3). *Note: Finger tight only. Do not over tighten.*

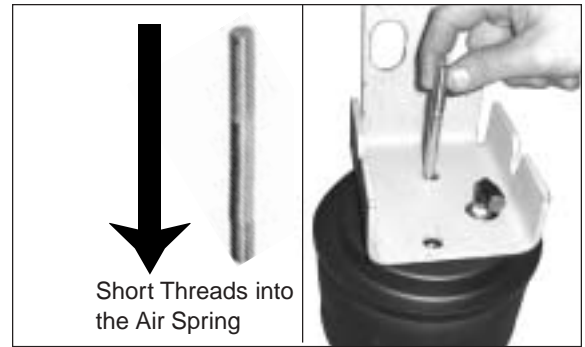

Figure 3

4. LOOSELY install the 3/8" lock washer (O) and 3/8" x 7/8" hex head cap screws (N). Leave loose to allow installation of the upper bracket.

5. Attach the lower bracket (D) to the bottom of the air spring. Use the forward, inboard hole as shown in Figure 4.

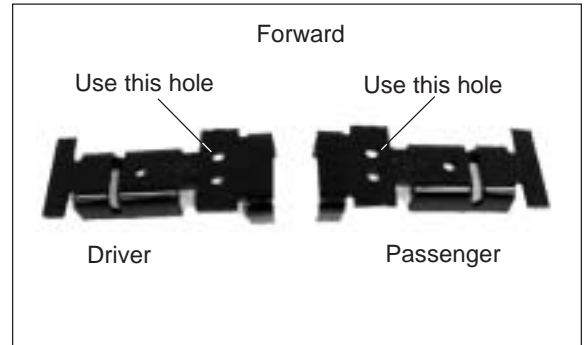

Figure 4

6. Set U-bolt into the slot on the lower bracket. Secure lower bracket (D) to the air spring using the 3/8" lock washers (O) and 3/8" x 7/8" hex head cap screws (N).

7. Torque to 20 ft-lbs. See Figure 5.

8. This completes the assembly of the Passenger side (Figure 6). Now assemble the Driver side (left hand) in the same manner.



Figure 5

III. Lowering the Suspension

It will be necessary to lower the suspension of the vehicle in order to provide clearance to install the air spring unit (Figure 7). The following are tips on lowering the axle or raising the frame. Please review them and determine how to proceed:

1. If the vehicle is raised with an axle contact hoist, place axle stands under the frame and lower the axle as needed.
2. If the vehicle is raised with a frame contact hoist, place axle stands under the axle and lower the frame as needed.
3. If the vehicle was raised with a jack and supported with axle stands on the frame, use a floor jack to lower the axle.



Figure 6



Figure 7

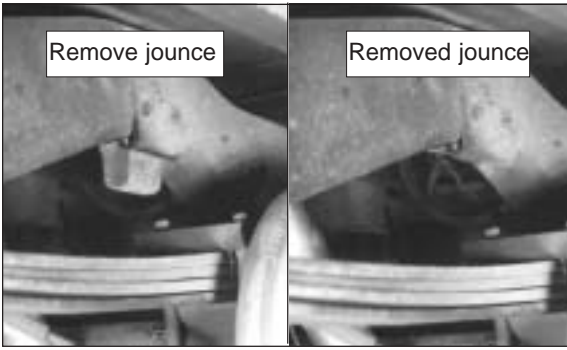

Figure 8

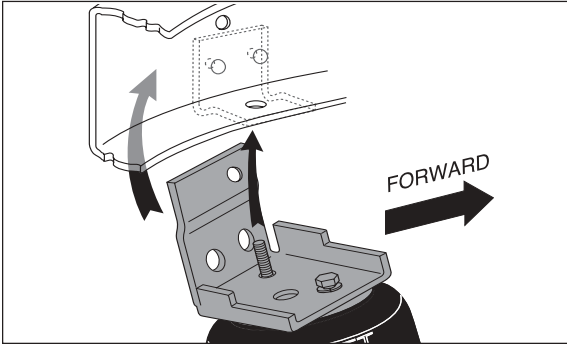

Figure 9

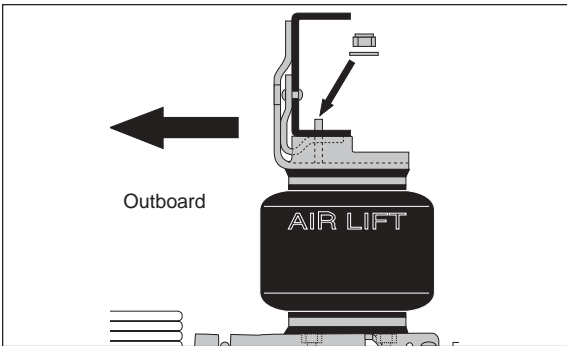

Figure 10



Figure 11a

Figure 11b



Figure 12

IV. Attaching the Upper Bracket

1. Unbolt and remove the rubber jounce bumper from the frame rail and discard (Figure 8).
2. With the $\frac{3}{8} \times \frac{7}{8}$ " hex head bolt (N) loose in the air spring, insert the stud through the original jounce bumper mounting hole (Figure 9).
3. Secure the stud using flat washer (L) and $\frac{3}{8}$ " lock nut (F). See Figure 10.
4. Tighten the hex head bolt securely to 16 ft–lbs.
5. **LATE MODELS** have an existing hole that lines up with the top hole in the bracket so it will not be necessary to drill on these models. On some models the existing hole may have a plastic stud for a wiring harness hanger protruding through it. Push the plastic stud back through the frame and use the existing hole to mount the upper bracket to the side of the frame rail.

NOTE: If there is a vent tube under the brake line bracket on the driver side, then the upper bracket will hit on this during installation. This line will have to be relocated on top of the brake line bracket to provide clearance for the upper bracket.

6. If there is no hole, select one of the small holes on the outboard side of the upper bracket that is not on the radius edge of the frame rail. *CAUTION: Do not drill holes into frame before checking for hydraulic lines, gas lines and/or electrical wires that may have to be moved aside on either side of the frame.* Using the upper bracket as a template, center-punch the hole location to be drilled (Figure 11a). Drill a $\frac{5}{16}$ " hole in the frame rail (Figure 11b).
7. Install $\frac{5}{16}$ " x 1" hex head cap screws (I), flat washers (L) and $\frac{5}{16}$ " lock nut (K). Torque to 15 ft–lbs (Figure 12).

V. Attaching the Lower Bracket

1. Position the lower bracket so the inboard leg straddles the brake line. On disk brake models, it may be necessary to loosen the axle vent bolt (Figure 13) and rotate the brake junction box clockwise to clear rear leg of lower bracket.

NOTE on models with drum brakes: Check to be sure that the lower bracket is not pinching the brake line on the axle. If it is then, bend the tab holding the brake line away from the axle housing (Figure 14). Reposition the line and bend the tab back to hold the line in that position.

2. Position the lower bracket so that the outboard edge is between the leaf spring U-bolts (Figure 15). Insert the U-bolt (G) provided in the outboard slot of the lower bracket (Figure 16).

3. Secure the lower bracket to the axle using the saddle clamps (H), flat washers (L) and $\frac{3}{8}$ " nuts (K). See Figure 16.

NOTE: Late model vehicles have a small brake line hanger on the passenger side. This may need to be bent in order to gain brake line to saddle clamp clearance. DO NOT LET THE BRAKE LINE RUB AGAINST THE SADDLE CLAMP.

4. Torque nuts to 16 ft-lbs (Figure 16). Trim excess bolt off if desired.

5. See Figure 17 for the completed installation of the lower bracket.

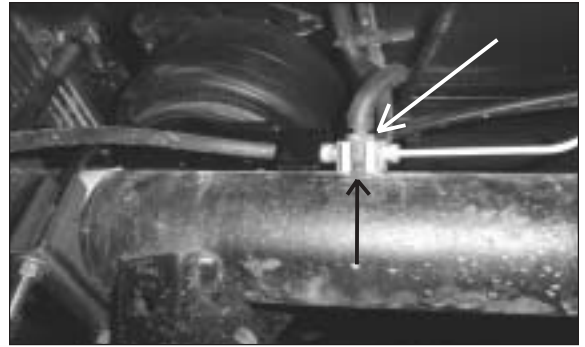

Figure 13

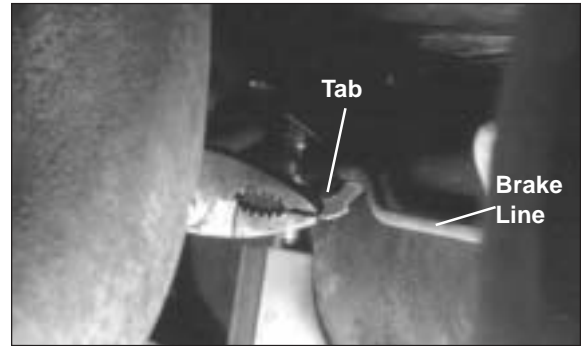

Figure 14

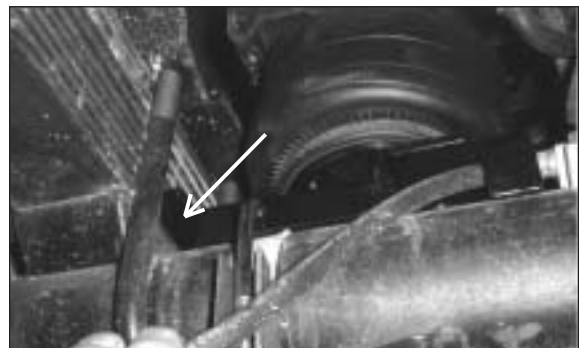

Figure 15



Figure 16



Figure 17

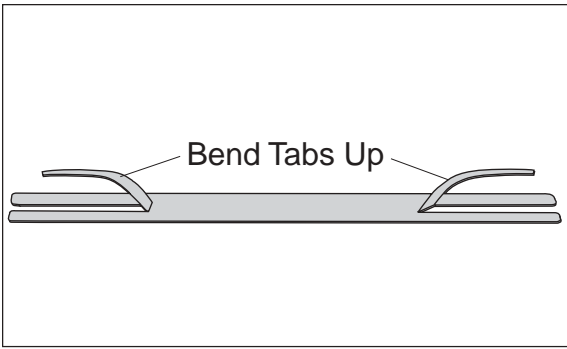

Figure 18

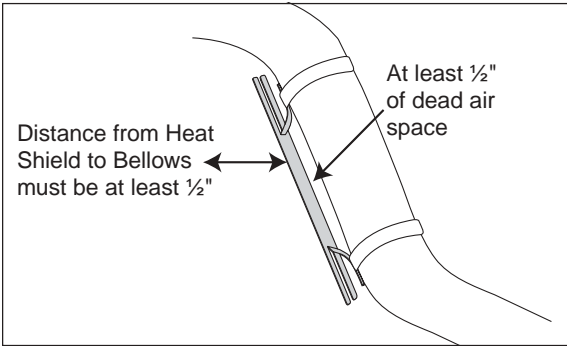

Figure 19

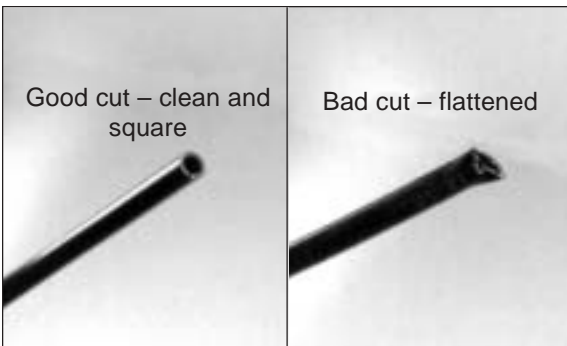

Figure 20a

Figure 20b

VI. Installing the Heat Shield

1. Bend tabs to provide a $\frac{1}{2}$ " dead air space between exhaust pipe and heat shield (Figure 18).
2. Attach the heat shield (E) to the exhaust pipe using the provided clamps (Figure 19). Bend the heat shield for maximum clearance to the air spring.
3. NOTE: A slight adjustment to the exhaust system may be required to gain enough clearance to install the heat shield.
 - a. If there is insufficient room for installation of the heat shield, loosen the exhaust clamp between the muffler and the catalytic converter.
 - b. Push the muffler and tailpipe toward the rear of the vehicle, retain a minimum of $\frac{3}{4}$ " between tailpipe and frame crossmember and retighten the clamp.

VII. Installing the Other Air Spring

Installation for one of the air springs is now complete. Continue by completing steps II-V for the other side.

VIII. Installing the Air Lines

1. Choose a convenient location for mounting the inflation valves. Popular locations for the inflation valve are: wheel well flanges, license plate recess in bumper, under the gas cap access door, or through license plate itself. NOTE: *What ever the chosen location is, make sure there is enough clearance around the inflation valves for an air chuck.*
2. Drill a $\frac{5}{16}$ " hole to install the inflation valves.
3. Cut the air line assembly (AA) in two equal lengths. CAUTION: *When cutting or trimming the air line, use a hose cutter (Air Lift P/N 10530), a razor blade or a sharp knife. A clean, square cut will ensure against leaks. (Figure 20a). Do not use wire cutters or scissors to cut the air line. These tools may flatten or crimp the air line, causing it to leak around the O-ring seal inside the elbow fitting (Figure 20b).*

4. Place a $\frac{5}{16}$ " nut (GG) and a star washer (FF) on the air valve. Leave enough of the inflation valve in front of the nut to extend through the hole and have room for the rubber washer (EE), flat washer (DD), and $\frac{5}{16}$ " nut (GG) and cap (CC). There should be enough valve exposed after installation - approximately $\frac{1}{2}$ " - to easily apply a pressure gauge or an air chuck (Figure 21).

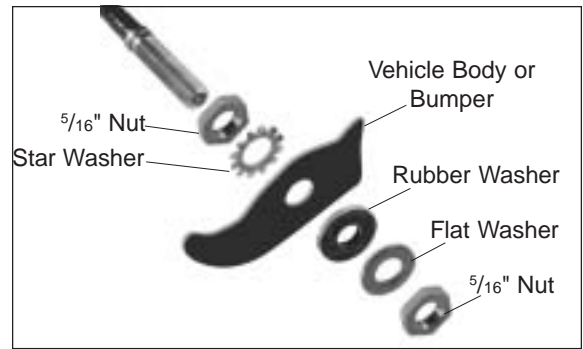

Figure 21

5. Push the inflation valve through the hole and use the rubber washer (EE), flat washer (DD), and another $\frac{5}{16}$ " nut (GG) to secure it in place. Tighten the nuts to secure the assembly in place (Figure 21).

6. Route the air line along the frame to the air fitting on the air spring. Keep at least 6" of clearance between the air line and heat sources, such as the exhaust pipes, muffler, or catalytic converter. Avoid sharp bends and edges. Use the plastic tie straps (BB) to secure the air line to fixed, non-moving points along the chassis. Be sure that the tie straps are tight, but do not pinch the air line. Leave at least 2" of slack to allow for any movement that might pull on the air line.

7. On the Passenger side only, place the provided thermal sleeve on the air line near the exhaust.

8. Using a standard tube cutter, a razor blade, or very sharp knife to cut the air line. Cut off air line leaving approximately 12" of extra air line. A clean square cut will ensure against leaks. Insert the air line into the air fitting. This is a push to connect fitting. Simply push the air line into the 90° swivel fitting until it bottoms out ($\frac{9}{16}$ " of air line should be in the fitting).

IX. Installing the Decal

Install the minimum/maximum air pressure decal in a highly visible location. We suggest placing it on the driver's side window, just above the door handle.

X. Checking for Leaks

1. Inflate the air spring to 60 p.s.i.

2. Spray all connections and the inflation valves with a solution of $\frac{1}{5}$ liquid dish soap and $\frac{4}{5}$ water to check for leaks. Leaks should be easily spotted by looking for bubbles in the soapy water.

3. After the test, deflate the springs to the minimum pressure required to restore the Normal Ride Height, but not less than 10 p.s.i.

4. **IMPORTANT:** Check the air pressure again after 24 hours. A 2 to 4 p.s.i. loss after initial installation is normal. Retest for leaks if the loss is more than 5 lbs.

XI. Fixing Leaks

1. If there is a problem with the swivel fitting, then:
 - a. Check the air line connection by deflating the spring and removing the line by pulling the collar against the fitting and pulling firmly on the air line. Trim 1" off the end of the air line. Be sure the cut is clean and square. Reinsert the air line into the push-to-connect fitting.
 - b. Check the threaded connection by tightening the swivel fitting another $\frac{1}{2}$ turn. If it still leaks, deflate the air spring, remove the fitting, and re-coat the threads with thread sealant. Reinstall by hand tightening as much as possible, then use a wrench for an additional two turns.
2. If there is a problem with the inflation valve, then:
 - a. Check the valve core by tightening it with a valve core tool.
 - b. Check the air line connection (Figure 33) by removing the air line from the barbed type fitting. *CAUTION: Do not cut it off. As this will usually nick the barb and render the fitting useless.* Cut air line off a few inches in front of the fitting and use a pair of pliers or vise-grips to pull/twist the air line off the fitting.
3. If the preceding steps have not resolved the problem, call Air Lift Technical Service at 1-800-248-0892 for assistance.

XII. Troubleshooting Guide

Problems maintaining air pressure, without on-board compressor.

1. Leak test the air line connections and threaded connection of the elbow into the air spring. See Section XI to repair.
2. Leak test the inflation valve for leaks at the air line connection or dirt or debris in the valve core. See Section XI for repair.
3. Inspect air lines to be sure it is not pinched. Tie straps may be too tight. Loosen or replace strap. Replace leaking components.
4. Inspect air line for holes and cracks. Replace as needed.
5. A kink or fold in the air line. Reroute as needed.

You have now tested for all of the most probable leak conditions that can be easily fixed. At this point the problem is most likely a failed air spring - either a factory defect or an operating problem. Please call Air Lift at 1-800-248-0892 for assistance or a replacement air spring.

XIII. Checklist

You can protect your warranty on this product and prevent unnecessary wear by ensuring the following checks have been made:

Section I – Installation (To be completed by the installer):

- 1. Clearance Test - Inflate the air springs to 60 p.s.i. and ensure there is at least 1/2 " clearance around each sleeve from anything that might rub against them. Be sure to check the tire, brake drum, frame, shock absorbers and brake cables.
- 2. Leak Test Before Road Test – Inflate the air springs to 60 p.s.i., check all connections for leaks with a soapy water solution. See page 8 of the manual for tips on how to spot leaks. All leaks must be eliminated before the vehicle is road tested.
- 3. Heat Test – Be sure there is sufficient clearance from heat sources - at least 6" for air springs and air lines. If a heat shield was included in the kit - install it. If there is no heat shield, but one is required, call 1-800-248-0892.
- 4. Fastener Test – Recheck all bolts for proper torque.

Torque Guide:

3/8 " Frame Bolts	16 ft–lbs
U-bolt Lock Nuts	16 ft–lbs
- 5. Road Test – The vehicle should be road tested after the preceding tests. Inflate the springs to 25 p.s.i. (50 p.s.i. if vehicle is loaded). Drive the vehicle 10 miles and recheck for clearance, loose fasteners and/or air leaks.
- 6. Operating Instructions – If professionally installed, the installer should review the operating instructions on page 10 with the owner. Be sure to provide the owner with all of the paperwork that came with the kit.

Section II - Post Installation Checklist (To be completed by the owner):

- 1. Overnight Leakdown Test – Recheck air pressure after vehicle has been used for 24 hours. If pressure has dropped more than 5 p.s.i. then, you have a leak that must be fixed. Either fix the leak yourself (see page 8) or return to the installer for service.
- 2. Air Pressure Requirements – I understand that the air pressure requirements of my air spring system are as follows:

Minimum _____ Maximum _____

I also understand that I must inflate the air springs until the Ride Height measurement that was recorded on page 3 has been restored. Regardless of load, the air pressure should always be adjusted so that the Ride Height is maintained at all times.

- 3. Thirty Day or 500 Mile Test. I understand that I must recheck the air spring system after 30 days or 500 miles, whichever comes first. If any part shows signs of rubbing or abrasion, the source should be identified and moved, if possible. If it is not possible to relocate the cause of the abrasion, the air spring may need to be remounted. If professionally installed, the installer should be consulted. Check all fasteners for tightness.

XIII. Maintenance and Operations

Minimum Air Pressure	Maximum Air Pressure
20 p.s.i.	100 p.s.i.
Minimum Air Pressure for Motorhomes/Commercial Vehicles	
50 p.s.i.	
<i>Failure to maintain correct minimum pressure (or pressure proportional to load), bottoming out, over-extension, or rubbing against another component will void the warranty.</i>	

By following these steps, vehicle owners will obtain the longest life and best results from their air springs.

1. Check the air pressure weekly.
2. Always maintain Normal Ride Height. Never inflate beyond 100 p.s.i.
3. If you develop an air leak in the system, use a soapy water solution to check all air line connections and the inflation valve core before deflating and removing the air spring.
4. When increasing load, always adjust the air pressure to maintain the Normal Ride Height. Increase or decrease pressure from the system as necessary to attain Normal Ride Height for optimal ride and handling. Remember that loads carried behind the axle (including tongue loads) require more leveling force (pressure) than those carried directly over the axle.
5. **IMPORTANT:** For your safety and to prevent possible damage to your vehicle, *do not exceed maximum Gross Vehicle Weight Rating (GVWR), as indicated by the vehicle manufacturer.* Although your air springs are rated at a maximum inflation pressure of 100 p.s.i. The air pressure actually needed is dependant on your load and GVWR, which may be less than 100 p.s.i. Check your vehicle owners manual and do not exceed the maximum load listed for your vehicle.
6. Always add air to springs in small quantities, checking the pressure frequently. Sleeves require less air volume than a tire and inflate quickly.
7. *Should it become necessary to raise the vehicle by the frame, make sure the system is at minimum pressure (20 p.s.i.) to reduce the tension on the suspension/brake components. Use of on-board leveling systems do not require deflation or disconnection.*



Thank you for purchasing Air Lift Products

Mailing Address:
AIR LIFT COMPANY
P.O. Box 80167
Lansing, MI 48908-0167

Street Address:
AIR LIFT COMPANY
2727 Snow Rd.
Lansing, MI 48917

Local Phone: (517) 322-2144
Fax: (517) 322-0240
<http://www.airliftcompany.com>

For Technical Assistance call 1-800-248-0892

“The Choice of the Professional Installer”

Printed in the USA