

Kit No. 57216 and 57128

www.airliftcompany.com

Please read these instructions completely before proceeding with installation

PARTS INCLUDED

Item	Description	Quantity
A	Bellow	2
B	Upper Bracket	2
C	Lower Bracket (Left)	1
D	Lower Bracket (Right)	1
E	Roll Plate (not in 57128)	4
F	Frame Brace	2
G	Elbow Fitting	2
H	3/8"-24 x 7/8" Bolt	8
I	3/8" Lock Washer	8
J	3/8" Flat Washer	24
K	3/8" Oversized Flat Washer	6
L	3/8"-16 x 3/4" Bolt	2
M	3/8"-16 x 1.5" Bolt	8
N	3/8"-16 x 6 Carriage Bolt	4
O	3/8" Nylock Nut	12
P	Axle Clamp	2
Q	Heat Shield*	1
R	Clamp*	2
S	Thermal Sleeve	1
-Air Line Assembly Parts-		
AA	Air Line Assembly	1
BB	Tie Strap*	6
CC	Valve Caps*	2
DD	5/16" Flat Washer*	2
EE	Rubber Washer*	2
FF	Small Star Washer*	2
GG	5/16" Hex Nut*	4

(* not shown in Figure 1)

Kit 57216

see inset for bellow assembly for 57128

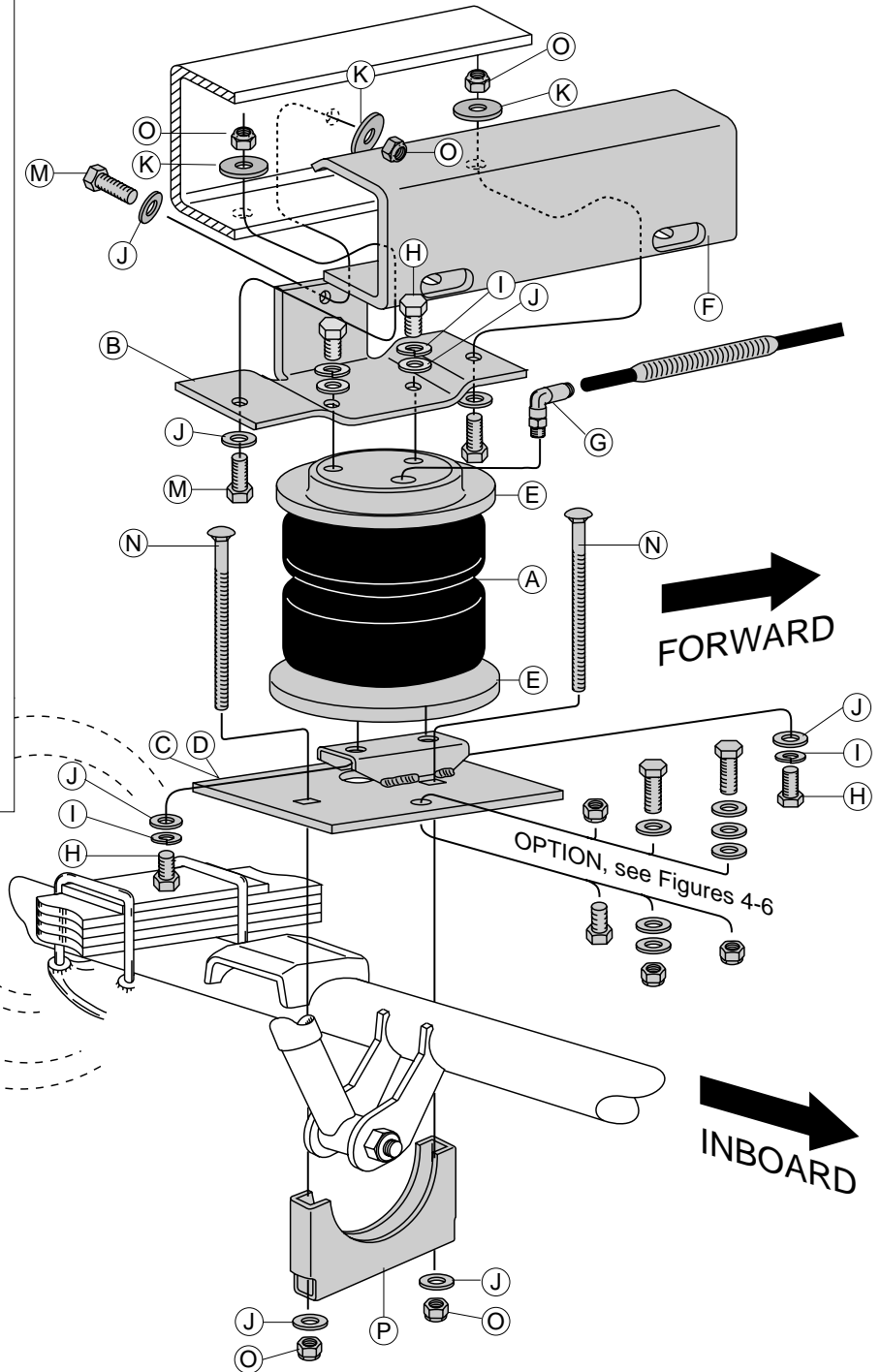

Kit 57128

NOTE: No roll plates are used.

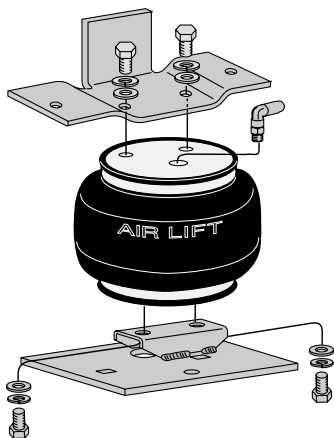

Figure 1

TOOLS NEEDED

$\frac{7}{16}$ " , $\frac{9}{16}$ " open-end or box wrenches
Crescent Wrench
Ratchet with $\frac{3}{8}$ " , $\frac{9}{16}$ " , and $\frac{1}{2}$ " deep well sockets
 $\frac{3}{8}$ " and $\frac{5}{16}$ " drill bits (very sharp)
 $\frac{3}{8}$ " Nut Driver
Heavy Duty Drill
Torque Wrench

Hose Cutter, Razor Blade, or Sharp Knife
Hoist or Floor Jacks
Safety Stands
Safety Glasses
Air Compressor, or Compressed Air Source
Spray Bottle with Dish Soap/Water Solution

NOTE: This instruction manual is for kits 57216 and 57128. The only difference between the two kits is the bellows. The drawings depict a double convolute bellow, as found in kit 57216. But all instructions and illustrations apply to kit 57128 as well, which uses a single convolute bellow.

IMPORTANT: The air springs will last much longer if they are not the suspension limiter in either compressor or extension. The air spring compresses to 2.8" and extends to 9.1". Regardless of load, the air pressure should always be adjusted so that the Normal Ride Height is maintained at all times. The shock absorber is usually the limiter on extension. If this is not the case, then the use of limiting straps should be considered, in particular for vehicles that are used off-road.

DANGER: Compressed air can cause injury and damage to the vehicle and parts if it is not handled properly. For your safety, do not try to inflate the air springs until they have been properly secured to the vehicle.

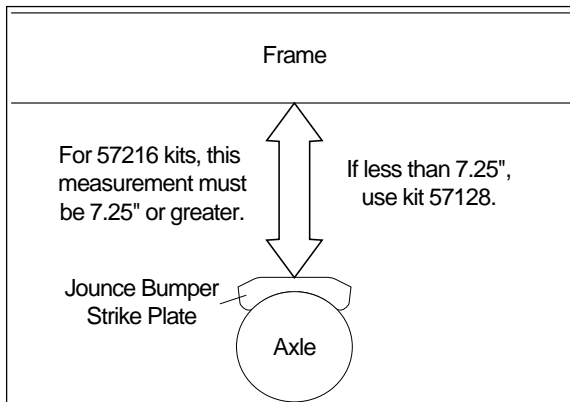

Figure 2

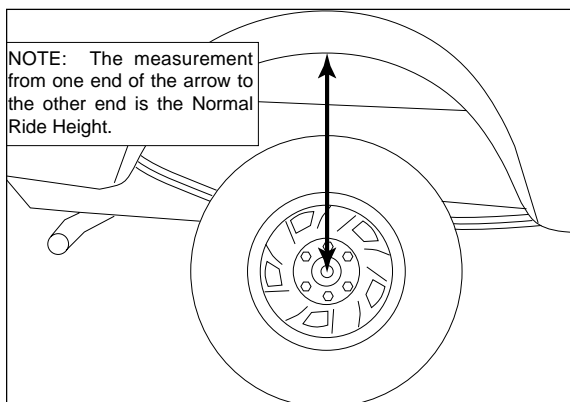

Figure 3

I. GETTING STARTED

1. The 57216 kit requires a minimum of 7.25" from the top of the jounce bumper strike plate to the bottom of the frame rail. Before installation is begun, check for sufficient clearance. If the measurement is less than 7.25", then use kit 57128 (Figure 2).
2. Determine the Normal Ride Height. The Normal Ride Height is the distance between the bottom edge of the wheel-well and the center of the hub with the vehicle in the "as delivered" condition. In some cases, Normal Ride Height is not perfectly level.
 - a. Remove unusual loads and examine your vehicle from the side to ensure it is on a level surface.
 - b. If necessary (in cases where your leaf springs are sagging badly), use a jack to raise the rear end so that the vehicle achieves the original "as delivered" ride height.
3. Measure the distance between the center of the hub and the bottom edge of the wheel well (Figure 3). This is the Normal Ride Height. Enter the measurement below:

NORMAL
RIDE HEIGHT: _____ inches

II. RAISING THE VEHICLE

1. Raise the vehicle and remove the wheels.
2. Check the distance between the center of the hub and the bottom edge of the wheel to ensure that it is at the normal ride height previously recorded. If not, raise the frame or lower the axle as necessary to restore the original distance.
 - a. If the vehicle is raised with an axle contact hoist, then place axle stands under the frame and lower the axle as needed.
 - b. If the vehicle is raised with a frame contact hoist, then place axle stands under the axle and raise the frame as needed.
 - c. If the vehicle is raised with a jack and supported with axle stands on the frame, then use a floor jack to lower the axle.

III. REMOVING THE JOUNCE BUMPER

1. Remove the jounce bumper by prying it off of the jounce bumper bracket.
2. Remove the jounce bumper bracket from the frame rail. It may be bolted or riveted. If riveted, it can be removed by center punching and drilling out the rivets, chiseling or grinding it off, or cutting it off with a torch.

IV. ASSEMBLING THE AIR SPRING UNIT

1. The lower brackets (C and D) are designated left/driver side (indicated by the "L" stamped on it) and right/passenger side (indicated by the stamped "R").
2. It will be necessary to use either the $\frac{3}{8}$ " x $\frac{3}{4}$ " (L) bolt or the $\frac{3}{8}$ " x 1.5" (M) in combination with flat washers (J) and a nylock nut (O) as a spacer stack so that the lower bracket sits flat on the axle housing/jounce bumper pad.

NOTE: As a general rule, $\frac{1}{2}$ and $\frac{3}{4}$ ton trucks and some 1 ton trucks with single rear wheels take the stack in Figure 4. Most 1 ton single rear wheels and some 1 ton dual rear wheel trucks take the stack in Figure 5. Most 1 ton dual rear wheel trucks take the stack in Figure 6.
3. Set the lower bracket on the axle housing to determine the appropriate spacer stack up.
4. Due to manufacturing tolerances, the shock mounting bracket may stop the lower bracket from sitting completely flat on the axle housing/jounce bumper pad. This may occur on only one side of the vehicle. In such instances, it will be necessary to use a grinder to trim the shock bracket until it is flat with the top of the axle housing (Figure 7).

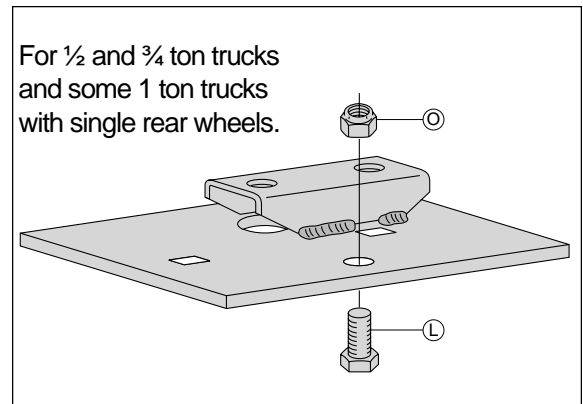

Figure 4

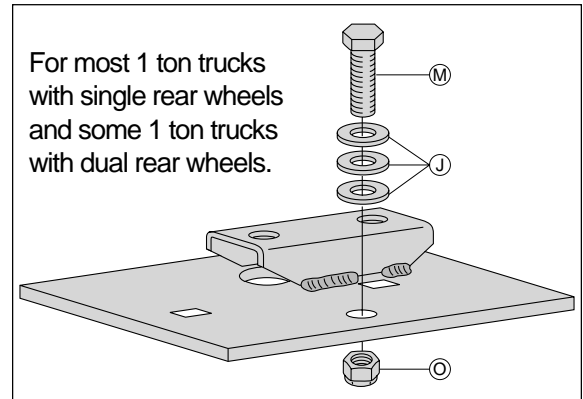

Figure 5

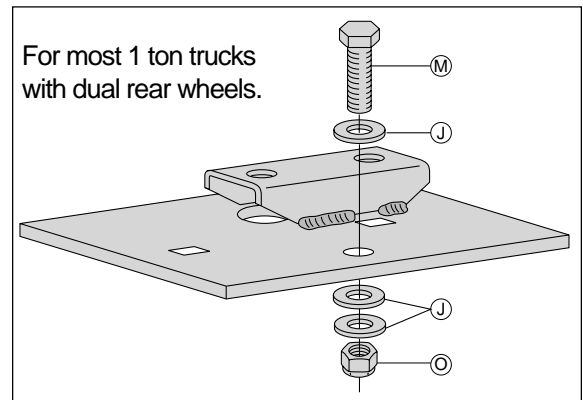

Figure 6

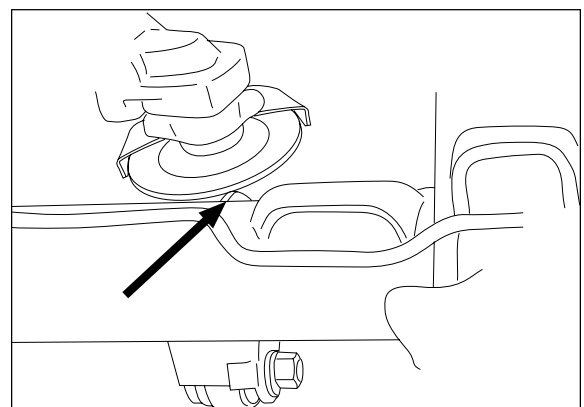

Figure 7

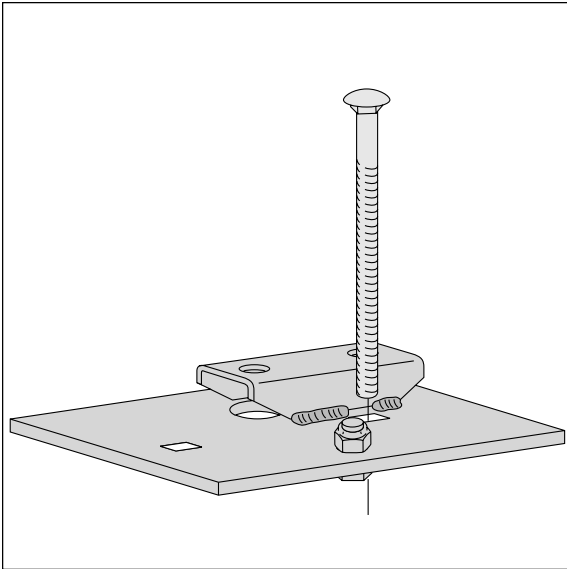

Figure 8

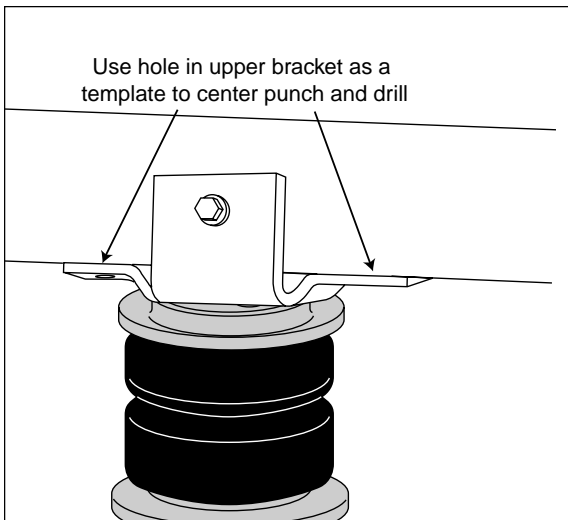

Figure 9

5. After determining and installing the appropriate stackup, insert one carriage bolt (N) into the forward hole of the lower bracket (Figure 8).
6. Set a roll plate (E) on both ends of the double convolute bellow (Figure 1). **Kit 57128 with the single convolute bellow does not require roll plates.**
7. Set the bellow assembly onto the lower bracket. The spacer assembly on the lower bracket must be positioned on the same side as the air port on the top of the air spring.
8. Attach the lower bracket to the bellow using two bolts (H), two lock washers (I), and two flat washers (J) (Figure 1).
9. Attach the upper bracket (B) to the bellow using two bolts (H), two lock washers (I), and two flat washers (J). Be sure that the tall vertical leg of the upper bracket is opposite of the air fitting port (Figure 1).
10. Repeat assembly for other side.

V. ATTACHING THE LOWER BRACKET

1. Set the assembly on the axle with the tall, wide vertical leg of the upper bracket on the outside of the frame rail. The lower bracket spacer sets just inboard of the jounce bumper pad on the axle housing.
2. Some models may require prying the brake line slightly away from the axle so that the axle clamp will not pinch the brake line.
3. Insert a carriage bolt (N) into the rearward hole in the lower bracket. Attach the bracket using the axle clamp (P), flat washers (J), and lock nuts (O). Torque to 20 ft-lbs.

VI. ATTACHING THE UPPER BRACKET

1. Align the air spring vertically and horizontally and clamp the upper bracket to the frame rail using a pair of vise grips or c-clamp.
2. **CAUTION:** Before drilling, be sure to check the back side of the frame rail for brake lines, gas lines, or electrical lines that may be in the way. It is necessary to move any interfering lines prior to drilling.
3. Using the upper bracket as a template center punch and drill a $\frac{3}{8}$ " hole through the outboard side of the frame rail and upper bracket.
4. Install one bolt (M), one flat washer (J), one oversized flat washer (K), and a lock nut (O). Torque to 44 ft-lbs and leave clamp in place.
5. Do not use the existing jounce bumper holes in the frame rail. Instead, use the holes in the upper bracket as a template along the bottom of the frame rail and center punch and drill two $\frac{3}{8}$ " holes through the holes in the upper bracket. Do not attach to the frame rail at this time. Remove the clamp or vise grips.

VII. INSTALLING THE FRAME BRACE

1. It may be necessary to cut or trim off the plastic locator studs (on '97 and new models) before installing the frame brace.
2. Install the frame brace (F) with the access holes toward the bottom of the frame rail. This is a tight fit and may require tapping with a hammer or mallet.
3. Align the access holes with the holes already drilled in the bottom of the frame. Using a large screw driver or punch through the already drilled hole, push the frame brace forward or backward until the holes are aligned.
4. Install a bolt (M), flat washer (J), oversized flat washer (K), and a lock nut (O). Hold the lock nut with a $\frac{9}{16}$ " open end wrench through the access hole and tighten the bolt to 44 ft-lbs. Repeat for other mounting hole.
5. Install the air fitting into the bellows. The threads are precoated with sealant. Tighten finger tight plus $1\frac{1}{2}$ turns, being careful to tighten only on the metal hex nut. Do not over tighten.

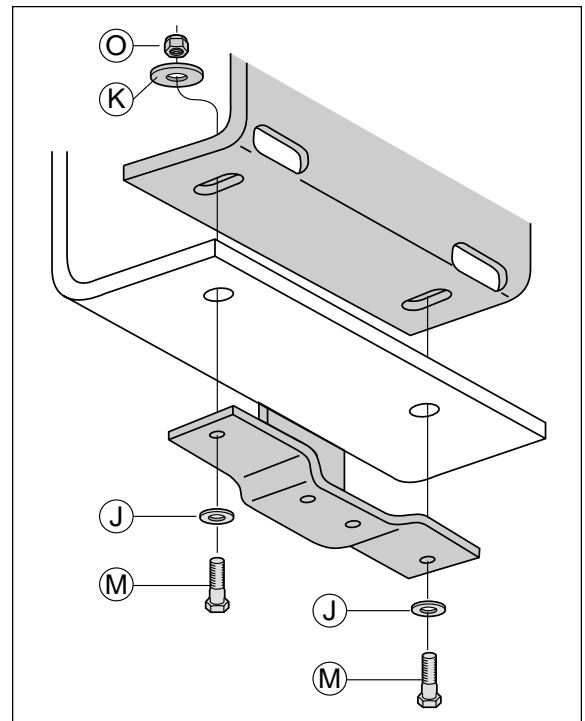

Figure 10

VIII. INSTALLING THE AIR LINES

1. Choose a convenient location for mounting the inflation valves. Popular locations for the inflation valve are:
 - a. The wheel well flanges.
 - b. License plate recess in bumper.
 - c. Under the gas cap access door.
 - d. Through license plate itself.

NOTE: What ever the chosen location is, make sure there is enough clearance around the inflation valves for an air chuck.

2. Drill a $\frac{5}{16}$ " hole to install the inflation valves.
3. Cut the air line assembly (AA) in two equal lengths.

CAUTION: When cutting or trimming the air line, use a hose cutter, a razor blade or a sharp knife. A clean, square cut will ensure against leaks. Do not use wire cutters or scissors to cut the air line. These tools may flatten or crimp the air line, causing it to leak around the O-ring seal inside the elbow fitting.

4. Place a $\frac{5}{16}$ " nut (GG) and a star washer (FF) on the air valve. Leave enough of the inflation valve in front of the nut to extend through the hole and have room for the rubber washer (EE), flat washer (DD), and $\frac{5}{16}$ " nut (GG) and cap (CC). There should be enough valve exposed after installation - approximately $\frac{1}{2}$ " - to easily apply a pressure gauge or an air chuck (Figure 11).
5. Push the inflation valve through the hole and use the rubber washer (EE), flat washer (DD), and another $\frac{5}{16}$ " nut (GG) to secure it in place. Tighten the nuts to secure the assembly in place (Figure 11).

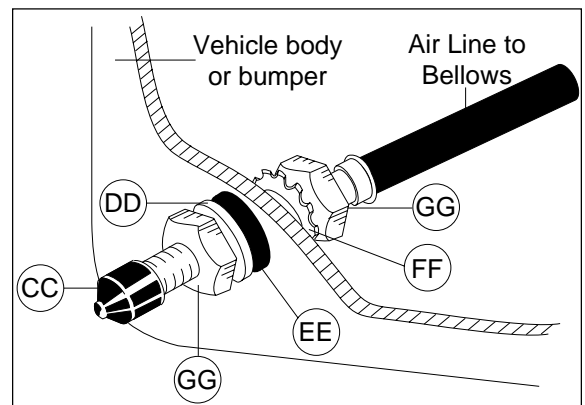

Figure 11

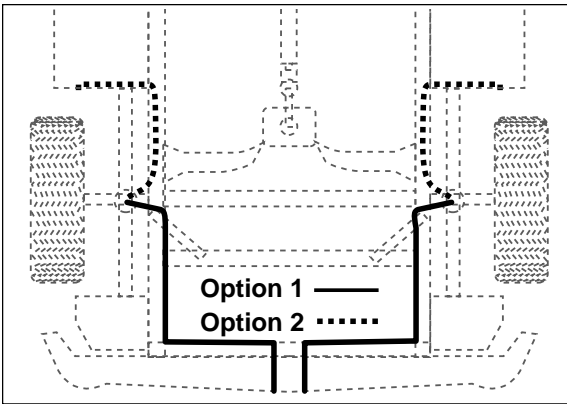

Figure 12

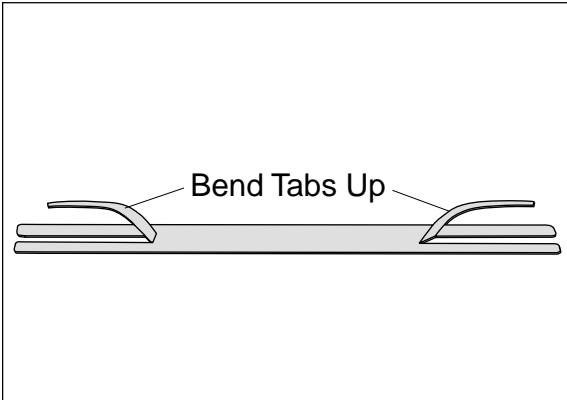

Figure 13

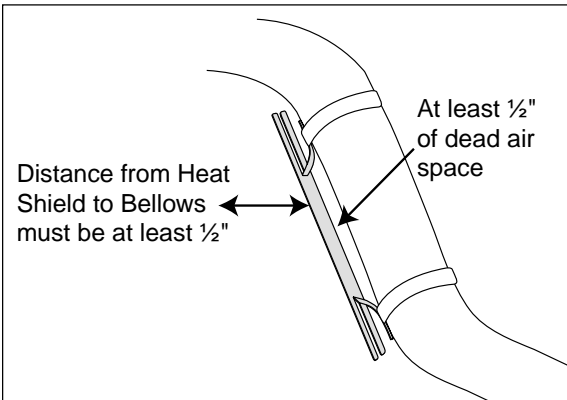

Figure 14

6. Route the air line along the frame to the air fitting on the air spring (Figure 12). Keep at least 6" of clearance between the air line and heat sources, such as the exhaust pipes, muffler, or catalytic converter. Avoid sharp bends and edges. Use the plastic tie straps (BB) to secure the air line to fixed, non-moving points along the chassis. Be sure that the tie straps are tight, but do not pinch the air line. Leave at least 2" of slack to allow for any movement that might pull on the air line.
7. On the passenger side only, place the provided thermal sleeve (S) on the air line near the exhaust.
8. Cut off air line leaving approximately 12" of extra air line. A clean square cut will ensure against leaks. Insert the air line into the air fitting. This is a push to connect fitting. Simply push the air line into the 90° swivel fitting until it bottoms out (⁹/₁₆" of air line should be in the fitting).
9. Install the minimum/maximum air pressure decal in a highly visible location. We suggest placing it on the driver's side window just above the door handle.

IX. INSTALLING THE HEAT SHIELD

1. Bend tabs to provide a $\frac{1}{2}$ " dead air space between exhaust pipe and heat shield (Figure 13).
2. Attach the heat shield (Q) to the exhaust pipe using the clamps (R) (Figure 14). Bend the heat shield for maximum clearance to the air spring.
3. On the driver side, it will be necessary to secure the emergency brake cable away from the air spring to prevent it from rubbing. Use the provided tie straps (BB).

X. CHECKING FOR LEAKS

1. Inflate the air spring to 60 p.s.i.
2. Spray all connections and the inflation valves with a solution of $\frac{1}{5}$ liquid dish soap and $\frac{4}{5}$ water to check for leaks. You should be able to spot leaks easily by looking for bubbles in the soapy water.
3. After the test, deflate the springs to the minimum pressure required to restore the Normal Ride Height, but not less than 5 p.s.i.
4. **IMPORTANT:** Check the air pressure again after 24 hours. A 2 to 4 p.s.i. loss after initial installation is normal. Retest for leaks if the loss is more than 5 lbs.

XI. FIXING LEAKS

1. If there is a problem with the swivel fitting, then:
 - a. Check the air line connection by deflating the spring and removing the line by pulling the collar against the fitting and pulling firmly on the air line. Trim 1" off the end of the air line. Be sure the cut is clean and square. Reinsert the air line into the push-to-connect fitting.
 - b. Check the threaded connection by tightening the swivel fitting another $\frac{1}{2}$ turn. If it still leaks, deflate the air spring, remove the fitting, and re-coat the threads with thread sealant. Reinstall by hand tightening as much as possible, then use a wrench for an additional two turns.
2. If there is a problem with the inflation valve, then:
 - a. Check the valve core by tightening it with a valve core tool.
 - b. Check the air line connection by removing the air line from the barbed type fitting. *CAUTION: Do not cut it off. As this will usually nick the barb and render the fitting useless.* Cut air line off a few inches in front of the fitting and use a pair of pliers or vise-grips to pull/twist the air line off the fitting.
3. If the preceding steps have not resolved the problem, call Air Lift Technical Service at 1-800-248-0892 for assistance.

XII. TROUBLESHOOTING GUIDE

Problems maintaining air pressure, without on-board compressor.

1. Leak test the air line connections and threaded connection of the elbow into the air spring. See Section XII to repair.
2. Leak test the inflation valve for leaks at the air line connection or dirt or debris in the valve core. See Section XII to repair.
3. Inspect air lines to be sure it is not pinched. Tie straps may be too tight. Loosen or replace strap. Replace leaking components.
4. Inspect air line for holes and cracks. Replace as needed.
5. A kink or fold in the air line. Reroute as needed.

You have now tested for all of the most probable leak conditions that can be easily fixed. At this point the problem is most likely a failed air spring - either a factory defect or an operating problem. Please call Air Lift at 1-800-248-0892 for assistance or a replacement air spring.

XIII. CHECKLIST

You can protect your warranty on this product and prevent unnecessary wear by ensuring the following checks have been made:

Section I – Installation (To be completed by the installer):

- 1. Clearance Test - Inflate the air springs to 60 p.s.i. and ensure there is at least 1/2 " clearance around each sleeve from anything that might rub against them. Be sure to check the tire, brake drum, frame, shock absorbers and brake cables.
- 2. Leak Test Before Road Test – Inflate the air springs to 60 p.s.i., check all connections for leaks with a soapy water solution. See pages 6 and 7 of the manual for tips on how to spot leaks. All leaks must be eliminated before the vehicle is road tested.
- 3. Heat Test – Be sure there is sufficient clearance from heat sources - at least 6" for air springs and air lines. If a heat shield was included in the kit - install it. If there is no heat shield, but one is required, call 1-800-248-0892.
- 4. Fastener Test – Recheck all bolts for proper torque.

Torque Guide:

3/8 " Frame Bolts	44 ft–lbs
Carriage Bolt Lock Nuts	20 ft–lbs

- 5. Road Test – The vehicle should be road tested after the preceding tests. Inflate the springs to 25 p.s.i. (50 p.s.i. if vehicle is loaded). Drive the vehicle 10 miles and recheck for clearance, loose fasteners and/or air leaks.
- 6. Operating Instructions – If professionally installed, the installer should review the operating instructions on page 9 with the owner. Be sure to provide the owner with all of the paperwork that came with the kit.

Section II - Post Installation Checklist (To be completed by the owner):

- 1. Overnight Leakdown Test – Recheck air pressure after vehicle has been used for 24 hours. If pressure has dropped more than 5 p.s.i. then, you have a leak that must be fixed. Either fix the leak yourself (see pages 6-7) or return to the installer for service.
- 2. Air Pressure Requirements – I understand that the air pressure requirements of my air spring system are as follows:

Minimum _____ Maximum _____

I also understand that I must inflate the air springs until the Ride Height measurement that was recorded on page 2 has been restored. Regardless of load, the air pressure should always be adjusted so that the Ride Height is maintained at all times.

- 3. Thirty Day or 500 Mile Test. I understand that I must recheck the air spring system after 30 days or 500 miles, whichever comes first. If any part shows signs of rubbing or abrasion, the source should be identified and moved, if possible. If it is not possible to relocate the cause of the abrasion, the air spring may need to be remounted. If professionally installed, the installer should be consulted. Check all fasteners for tightness.

XIV. MAINTENANCE AND OPERATIONS

Minimum Air Pressure	Maximum Air Pressure
5 p.s.i.	100 p.s.i.
<i>Failure to maintain correct minimum pressure (or pressure proportional to load), bottoming out, over-extension, or rubbing against another component will void the warranty.</i>	

By following these steps, vehicle owners will obtain the longest life and best results from their air springs.

1. Check the air pressure weekly.
2. Always maintain Normal Ride Height. Never inflate beyond 100 p.s.i.
3. If you develop an air leak in the system, use a soapy water solution to check all air line connections and the inflation valve core before deflating and removing the air spring.
4. When increasing load, always adjust the air pressure to maintain the Normal Ride Height. Increase or decrease pressure from the system as necessary to attain Normal Ride Height for optimal ride and handling. Remember that loads carried behind the axle (including tongue loads) require more leveling force (pressure) than those carried directly over the axle.
5. **IMPORTANT:** For your safety and to prevent possible damage to your vehicle, *do not exceed maximum Gross Vehicle Weight Rating (GVWR), as indicated by the vehicle manufacturer.* Although your air springs are rated at a maximum inflation pressure of 100 p.s.i. The air pressure actually needed is dependant on your load and GVWR, which may be less than 100 p.s.i. Check your vehicle owners manual and do not exceed the maximum load listed for your vehicle.
6. Always add air to springs in small quantities, checking the pressure frequently. Sleeves require less air volume than a tire and inflate quickly.
7. *Should it become necessary to raise the vehicle by the frame, make sure the system is at minimum pressure (5 p.s.i.) to reduce the tension on the suspension/brake components. Use of on-board leveling systems do not require deflation or disconnection.*



Thank you for purchasing Air Lift Products

Mailing Address:
AIR LIFT COMPANY
P.O. Box 80167
Lansing, MI 48908-0167

Street Address:
AIR LIFT COMPANY
2710 Snow Rd.
Lansing, MI 48917

Local Phone: (517) 322-2144

Fax: (517) 322-0240

<http://www.airliftcompany.com>

For Technical Assistance call 1-800-248-0892

“The Choice of the Professional Installer”

Printed in the USA