

## Kit No. 57340

www.airliftcompany.com

*Please read these instructions completely before proceeding with installation*

### Air Spring Kit Parts List

Item	Description	Quantity
A	Air Springs	2
B1	Upper Bracket - Driver-Side	1
B2	Upper Bracket - Passenger-Side	1
C	Lower Brackets	2
D	Roll Plate	4
E	Air Fitting	2



### Attaching Hardware

Item	Description	Quantity
F	3/8" x 1.5" Hex Head Cap Screw	2
G	3/8" x 2" Carriage Bolts	2
H	3/8" x 3.5" Hex Head Cap Screw	2
I	3/8" Flat Washers - Large O.D.	2
J	3/8" Nuts	6
K	3/8" Flat Washers	9
L	Thermal Sleeve	1
M	3/8" x 7/8" Hex Head Bolts	8
N	Lock Washers	8

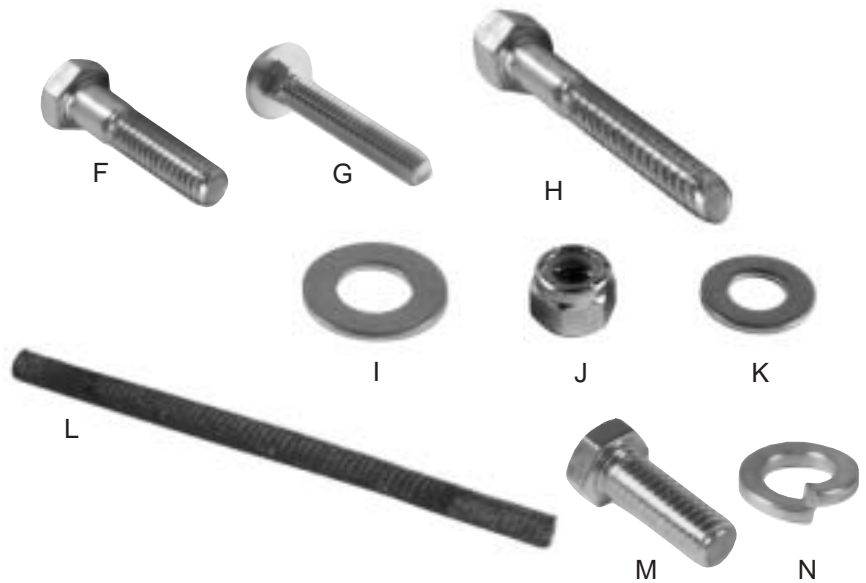

### Air Line Assembly Parts List

Item	Description	Quantity
AA	Air Line Assembly	1
BB	Tie Strap	6
CC	Valve Caps	2
DD	5/16" Flat Washer	2
EE	Rubber Washer	2
FF	Star Washer	2
JJ	5/16" Hex Nut	4

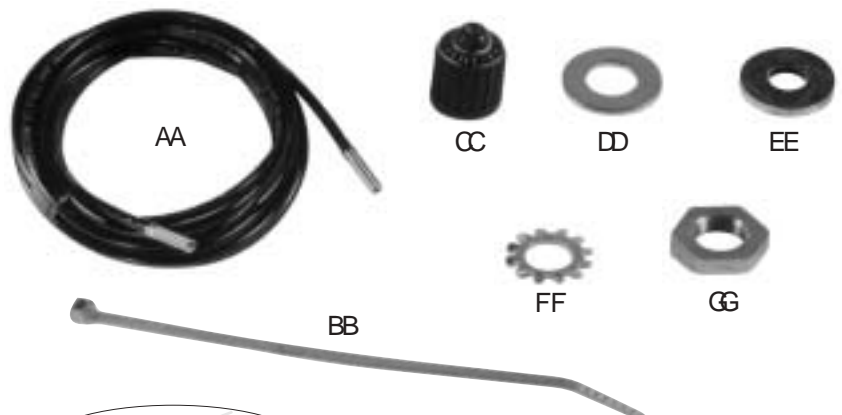

## Tools Needed

$\frac{5}{16}$ "  $\cdot \frac{7}{16}$ " ,  $\frac{9}{16}$ " and 19mm open-end or box wrenches  
Crescent Wrench  
Ratchet with  $\frac{9}{16}$ " and  $\frac{1}{2}$ " deep well sockets  
 $\frac{3}{8}$ " and  $\frac{5}{16}$ " drill bits (very sharp)  
Heavy Duty Drill  
Torque Wrench

Hose Cutter, Razor Blade, or Sharp Knife  
Hoist or Floor Jacks  
Safety Stands  
Safety Glasses  
Air Compressor, or Compressed Air Source  
Spray Bottle with Dish Soap/Water Solution

**IMPORTANT:** Your vehicle may be equipped with a rear brake proportioning valve. Any type of load assist product could affect brake performance. We recommend that you check with your dealer before installing this type of product. If your vehicle DOES NOT have a rear brake proportioning valve or is equipped with an anti-lock type brake system, installation of a load assist product will have NO EFFECT ON BRAKE SYSTEM PERFORMANCE.

**DANGER:** Compressed air can cause injury and damage to the vehicle and parts if it is not handled properly. For your safety, do not try to inflate the air sleeves until they have been properly secured to the vehicle.



## I. Getting Started

1. Determine the Normal Ride Height. The Normal Ride Height is the distance between the bottom edge of the wheel-well and the center of the hub with the vehicle in the "as delivered" condition. In some cases, Normal Ride Height is not perfectly level.
  - a. Remove unusual loads and examine your vehicle from the side to ensure it is on a level surface.
  - b. If necessary (in cases where your leaf springs are sagging badly), use a jack to raise the rear end so that the vehicle achieves the original "as delivered" ride height.
2. Measure the distance between the center of the hub and the bottom edge of the wheel well. This is the Normal Ride Height. Enter the measurement below:

NORMAL  
RIDE HEIGHT: \_\_\_\_\_ inches



## II. Assembling the Air Spring Unit

1. Set the roll plate (D) on the top and bottom of the bellows.
2. Install the swivel air fitting (E) into the top of the air spring (A). This fitting is pre-coated with sealant. Tighten finger-tight plus one and one-half turns with an open-end wrench to seal the fitting.

*NOTE:* Use a 7/16" open-end wrench being careful to tighten on the metal hex nut only.

DO NOT OVERTIGHTEN.

3. Insert carriage bolt (G) up through the driver-side upper bracket (B1) (Figure 1).
4. Set the bracket and carriage bolt assembly on top of the bellows. Attach with two bolts (M) and lock washers (N) (Figure 2).
5. On late model Excursions, it may be necessary to splay the tabs on the lower bracket to fit the jounce bumper strike plate properly. Do this by putting the bracket in a vice and bending the tabs slightly with a crescent wrench (Figure 3b). Check fit by sliding lower bracket onto the jounce bumper strike plate. It may be necessary to tap into place using a hammer (Figure 7).
6. Attach the lower bracket (C) to the bottom of the bellows with the tabs down. The tabs should be on the same side as the tall edge of the upper bracket (Figure 3a). Use two bolts (M) and lock washers (N). Tighten upper and lower brackets to the bellows to 15 ft/lbs.

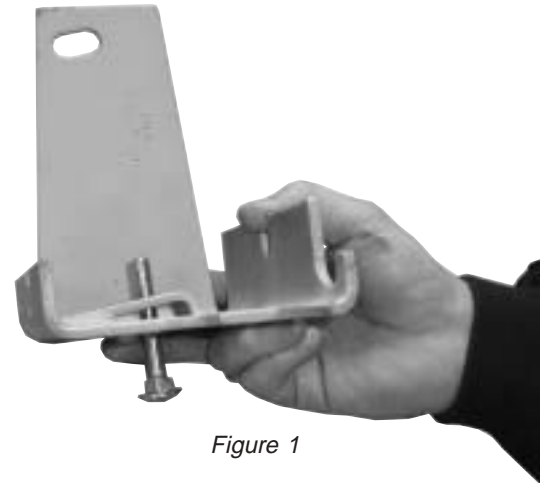

Figure 1



Figure 2



Figure 3a

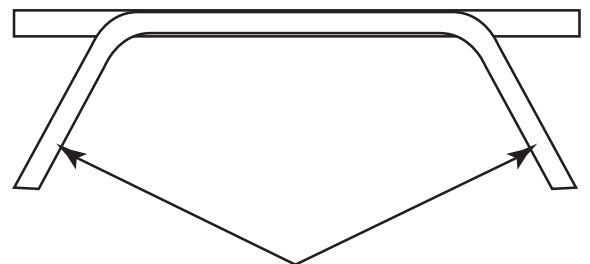

Splay the legs of the lower bracket for late model Excursions

Figure 3b



Figure 4

### III. Removing the Jounce Bumper and Loosening the Brake Cable

1. Remove the jounce bumper. The bellows will mount in place of the jounce bumper (Figure 4).
2. The driver-side emergency brake cable must be unbolted. Remove the nut and cable bracket, pull loose from the frame (Figure 5). Retain the fasteners for re-attaching the cable bracket.



Figure 5

### IV. Lowering the Suspension

*It will be necessary to lower the suspension to provide clearance to install the air spring unit.*

*This can be done by lowering the axle or raising the frame.*

- a. If the vehicle is raised with an axle contact hoist, place axle stands under the frame and lower the axle as needed.
- b. If the vehicle is raised with a frame contact hoist, place axle stands under the axle and raise the frame as needed.
- c. If the vehicle was raised with a jack and supported with axle stands on the frame, use a floor jack to lower the axle.



Figure 6

### V. Installing the Air Spring

1. The air spring unit assembled in the previous step will install on the driver-side. Set the unit in place by inserting the carriage bolt up through the jounce bumper hole (Figure 6).

Make sure the emergency brake cable is not caught between the upper bracket and the frame.

The bracket should fit flush against the outside of the frame. The tab on the lower bracket straddles the jounce bumper strike plate.

2. Push the lower bracket towards the spring so that the tab locks around the strike plate as illustrated in figure 7.

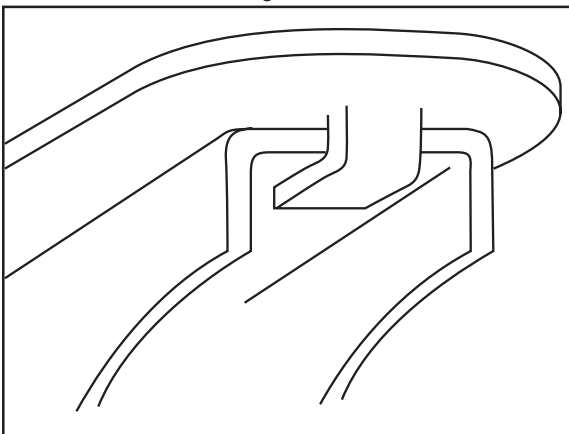

Figure 7

3. Insert the existing emergency brake cable bolt through the frame and slot in the upper bracket. Install washer (K) over the bolt, and push against the upper bracket (Figure 8).
4. Install the previously removed emergency brake cable and nut (Figure 9). Leave loose at this time.

*NOTE: In late model vehicles, a self-tapping bolt may have been used to attach the emergency brake cable bracket. If this is the case for your vehicle, remove the self-tapper and use the supplied bolt, washers, and locknut to re-attach the brake cable bracket and the upper bracket to the frame.*

*NOTE: Passenger-side will use bolt (F), washers (I), and nut (J) to attach the upper bracket to the existing hole on the side of the frame (Figure 10).*

5. Install nut (J) and washer (K) on the carriage bolt inserted through the existing jounce bumper bracket hole (Figure 11).



Figure 8



Figure 9

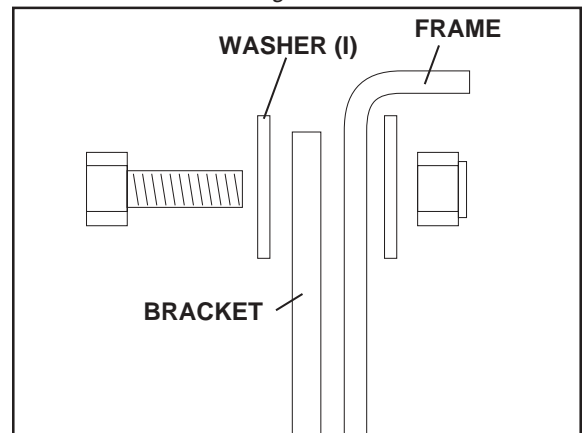

Figure 10



Figure 11



Figure 12

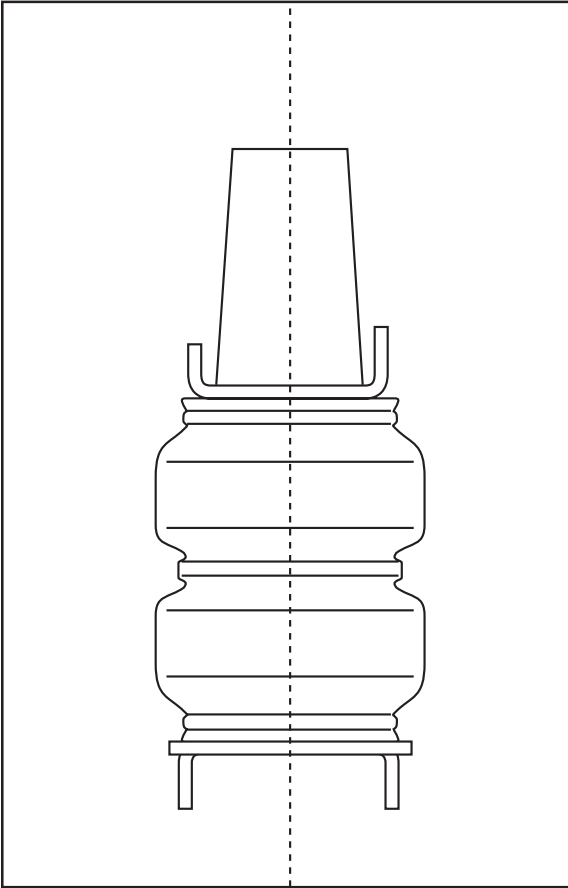

Figure 13



Figure 14

6. Raise the axle or drop the body to the previously recorded normal ride height.
7. Align the upper bracket forward or backward, ensuring the upper and lower brackets are lined up evenly with the bellows (Figures 12 and 13). Tighten the upper bracket mounting hardware to 15 ft/lbs.
8. As in the previous step, move the bottom bracket inward and outward so as to align it with the bellows and the upper bracket (Figure 14).

9. Clamp the lower bracket to the strike plate with c-clamps or vice grips. Drill a 3/8" hole through the strike plate using the existing holes in the lower bracket as a template (Figure 15).

*NOTE: Use a C-clamp or welding clamp to assist in keeping the lower bracket as flat to the strike plate as possible before drilling.*

10. Insert a bolt (H) and washer (K) through the bracket and strike plate. Install a washer (K) and nut (J) and torque to 16 ft/lbs. (Figure 16).

## VI. Emergency Brake Cable

*This step is for the driver-side only.*

1. Set the emergency cable into the hook on the driver-side and install a cable tie to keep the cable from chaffing on the bellows (Figure 17).
2. The finished driver-side install is shown in figure 18.

## VII. Install Passenger-Side Air Spring

*You have now completed the installation for one air spring. For the passenger-side, remove the jounce bumper as explained in step III. Proceed to follow the instructions in step V.*

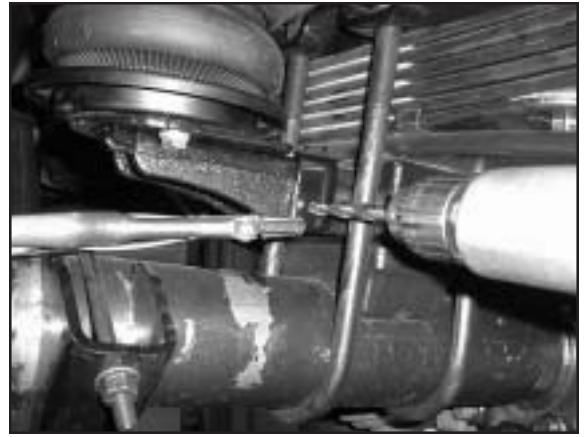

Figure 15



Figure 16



Figure 17



Figure 18

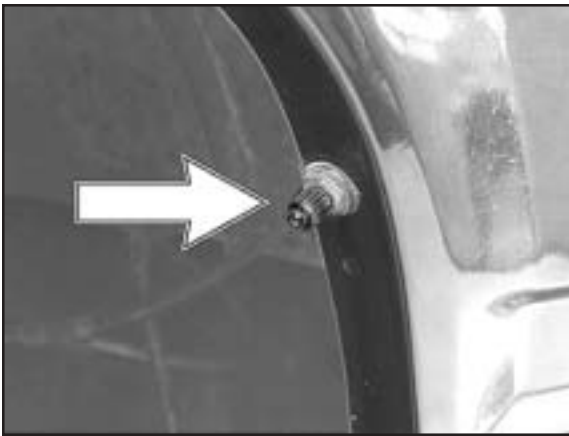

Figure 19



Figure 21

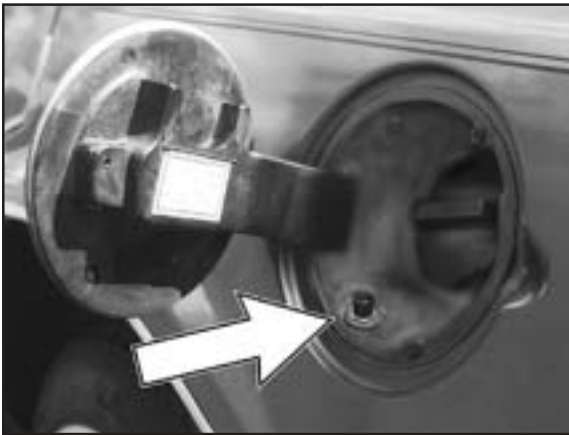

Figure 20



Figure 22

## VIII. Installing the Air Lines

1. Choose a convenient location for mounting the inflation valves. Popular locations for the inflation valve are: the wheel well flanges, the license plate recess in bumper, under the gas cap access door, or through license plate itself.

*NOTE: Whatever the chosen location is, make sure there is enough clearance around the inflation valves for an air chuck.*

2. Drill a  $\frac{5}{16}$ " hole to install the inflation valves.
3. Cut the air line assembly (AA) in two equal lengths (Figure 23).

*CAUTION: When cutting or trimming the air line, use a hose cutter (Air Lift P/N 10530), a razor blade or a sharp knife. A clean, square cut will ensure against leaks. Do not use wire cutters or scissors to cut the air line. These tools may flatten or crimp the air line, causing it to leak around the O-ring seal inside the elbow fitting.*

4. Place a  $\frac{5}{16}$ " nut (GG) and a star washer (FF) on the air valve (Figure 26). Leave enough of the inflation valve in front of the nut to extend through the hole and have room for the rubber washer (EE), flat washer (DD), and  $\frac{5}{16}$ " nut (GG) and cap (CC). There should be enough valve exposed after installation - approximately  $\frac{1}{2}$ " - to easily apply a pressure gauge or an air chuck (Figure 27).
5. Push the inflation valve through the hole and use the rubber washer (EE), flat washer (DD), and another  $\frac{5}{16}$ " nut (GG) to secure it in place. Tighten the nuts to secure the assembly in place.



Figure 23



Figure 26

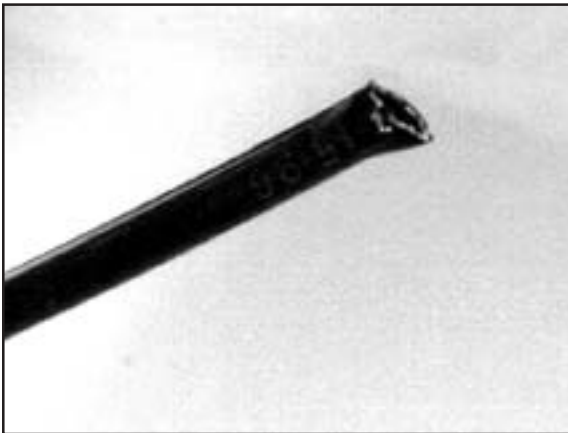

Figure 24



Figure 27

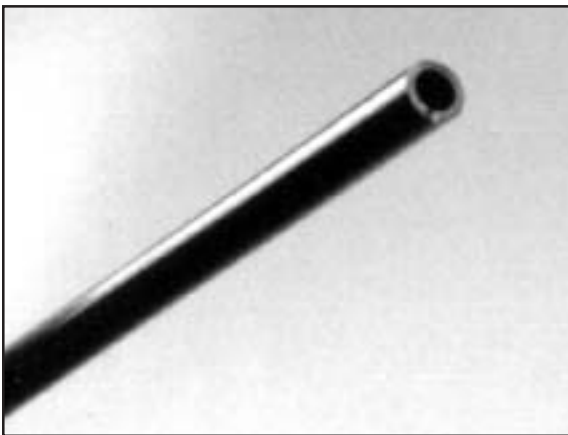

Figure 25



Figure 28

6. Route the air line along the frame to the air fitting on the air spring. Keep at least 6" of clearance between the air line and heat sources, such as the exhaust pipes, muffler, or catalytic converter. Avoid sharp bends and edges. Use the plastic tie straps (BB) to secure the air line to fixed, non-moving points along the chassis. Be sure that the tie straps are tight, but do not pinch the air line. Leave at least 2" of slack to allow for any movement that might pull on the air line (Figure 28).
7. The passenger side air line requires a thermal sleeve (L). Insert onto air line before installing into fitting.
8. Cut off the air line leaving approximately 12" of extra air line. A clean square cut will ensure against leaks. Insert the air line into the air fitting (Figure 29). This is a push to connect fitting. Simply push the air line into the 90° swivel fitting until it bottoms out ( $\frac{9}{16}$ " of air line should be in the fitting) (Figure 30).



*Figure 29*



*Figure 30*

## IX. Checking for Leaks

1. Inflate the air spring to 60 p.s.i.
2. Spray all connections and the inflation valves with a solution of  $\frac{1}{5}$  liquid dish soap and  $\frac{4}{5}$  water to check for leaks. You should be able to spot leaks easily by looking for bubbles in the soapy water.
3. After the test, deflate the springs to the minimum pressure required to restore the Normal Ride Height, but not less than 5 p.s.i.
4. **IMPORTANT:** Check the air pressure again after 24 hours. A 2 to 4 p.s.i. loss after initial installation is normal. Retest for leaks if the loss is more than 5 lbs.

## X. Fixing Leaks

1. If there is a problem with the swivel fitting:
  - a. Check the air line connection by deflating the spring and removing the line by pulling the collar against the fitting and pulling firmly on the air line. Trim 1" off the end of the air line. Be sure the cut is clean and square. Reinsert the air line into the push-to-connect fitting.
  - b. Check the threaded connection by tightening the swivel fitting another  $\frac{1}{2}$  turn. If it still leaks, deflate the air spring, remove the fitting, and re-coat the threads with thread sealant. Reinstall by hand tightening as much as possible, then use a wrench for an additional two turns.
2. If there is a problem with the inflation valve:
  - a. Check the valve core by tightening it with a valve core tool.
  - b. Check the air line connection by removing the air line from the barbed type fitting. **CAUTION: Do not cut it off. As this will usually nick the barb and render the fitting useless.** Cut the air line off a few inches in front of the fitting and use a pair of pliers or vice-grips to pull/twist the air line off the fitting.
3. If the preceding steps have not resolved the problem, call Air Lift Technical Service at 1-800-248-0892 for assistance.

## XI. Troubleshooting Guide

*Problems maintaining air pressure, without on-board compressor.*

1. Leak test the air line connections and threaded connection of the elbow into the air spring. See Section X to repair.
2. Leak test the inflation valve for leaks at the air line connection or dirt or debris in the valve core. See Section X to repair.
3. Inspect air lines to be sure it is not pinched. Tie straps may be too tight. Loosen or replace strap. Replace leaking components.
4. Inspect air line for holes and cracks. Replace as needed.
5. A kink or fold in the air line. Reroute as needed.

*You have now tested for all of the most probable leak conditions that can be easily fixed. At this point the problem is most likely a failed air spring - either a factory defect or an operating problem. Please call Air Lift at 1-800-248-0892 for assistance or a replacement air spring.*



### XIII. Maintenance and Operations

Minimum Air Pressure	Maximum Air Pressure
5 p.s.i.	100 p.s.i.
<i>Failure to maintain correct minimum pressure (or pressure proportional to load), bottoming out, over-extension, or rubbing against another component will void the warranty.</i>	

By following these steps, vehicle owners will obtain the longest life and best results from their air springs.

1. Check the air pressure weekly.
2. Always maintain Normal Ride Height. Never inflate beyond 100 p.s.i.
3. If you develop an air leak in the system, use a soapy water solution to check all air line connections and the inflation valve core before deflating and removing the air spring (see page 10).
4. When increasing load, always adjust the air pressure to maintain the Normal Ride Height. Increase or decrease pressure from the system as necessary to attain Normal Ride Height for optimal ride and handling. Remember that loads carried behind the axle (including tongue loads) require more leveling force (pressure) than those carried directly over the axle.
5. **IMPORTANT:** For your safety and to prevent possible damage to your vehicle, *do not exceed maximum Gross Vehicle Weight Rating (GVWR), as indicated by the vehicle manufacturer.* Although your air springs are rated at a maximum inflation pressure of 100 p.s.i. The air pressure actually needed is dependant on your load and GVWR, which may be less than 100 p.s.i. Check your vehicle owners manual and do not exceed the maximum load listed for your vehicle.
6. Always add air to springs in small quantities, checking the pressure frequently. Air springs require less air volume than a tire and inflate quickly.
7. *Should it become necessary to raise the vehicle by the frame, make sure the system is at minimum pressure (5 p.s.i.) to reduce the tension on the suspension/brake components. Use of on-board leveling systems do not require deflation or disconnection.*



***Thank you for purchasing Air Lift Products***

Mailing Address:  
AIR LIFT COMPANY  
P.O. Box 80167  
Lansing, MI 48908-0167

Street Address:  
AIR LIFT COMPANY  
2727 Snow Rd.  
Lansing, MI 48917

Local Phone: (517) 322-2144  
Fax: (517) 322-0240

For Technical Assistance call 1-800-248-0892

***“The Choice of the Professional Installer”***

Printed in the USA