

P/N 59526

Please read these instructions completely before proceeding with the installation.

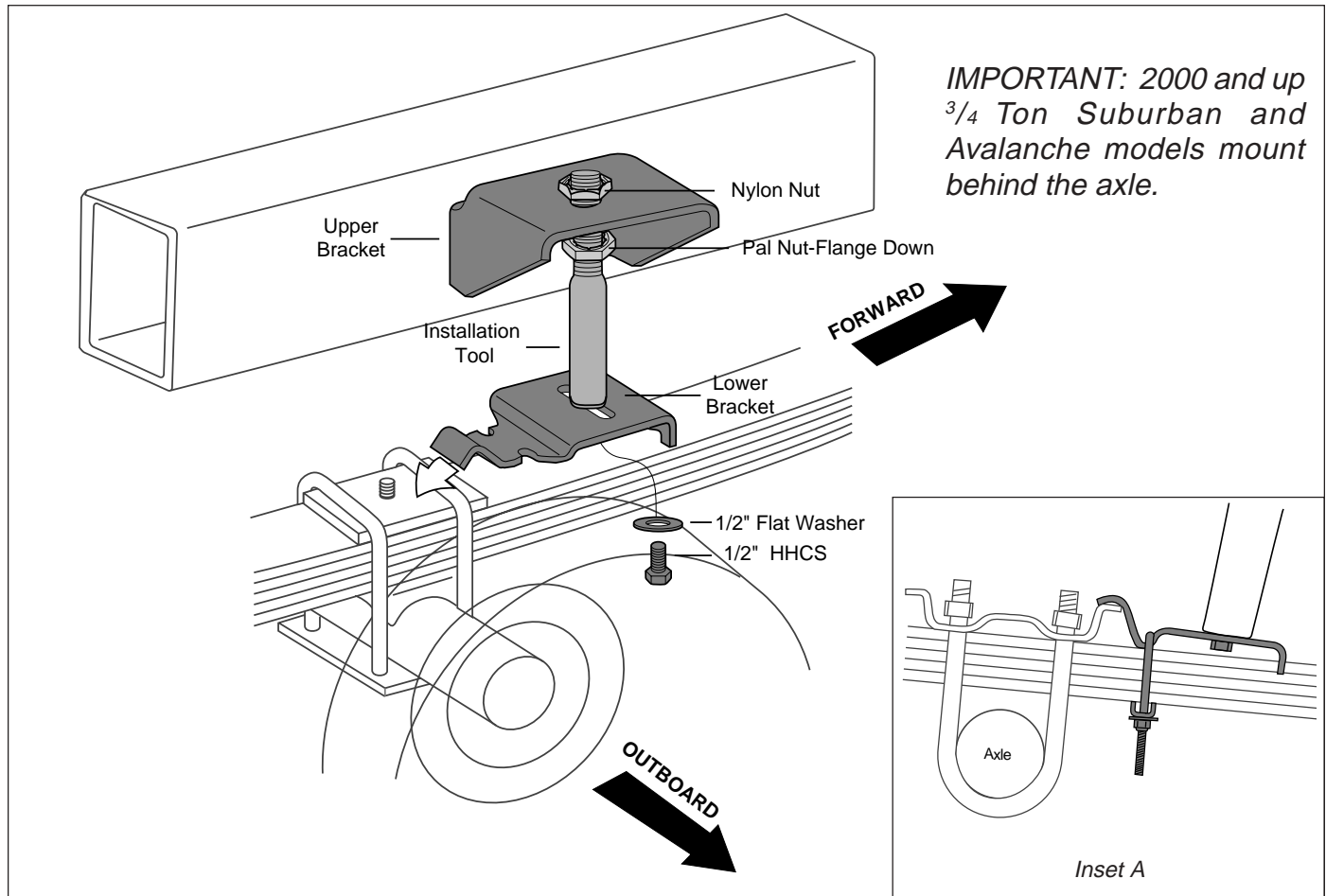

Figure 1

IMPORTANT: Your vehicle may be equipped with a rear brake proportioning valve. Any type of load assist product could affect brake performance. We recommend that you check with your dealer before installing this type of product. If your vehicle does not have a rear brake proportioning valve or is equipped with an anti-lock type brake system, installation of a load assist product will have no effect on brake system performance.

CAUTION: If not handled properly, compressed air can cause injury and damage to the vehicle and parts. *For your safety, do not try to inflate the air sleeves until they have been properly secured to the vehicle.*

IMPORTANT: This kit contains the new Air Lift installation tool. This tool is designed to simplify the installation of the kit for correct mounted height and alignment. The threaded section of the tool will ensure mounting of the air spring within the correct mounting envelope. The air spring may be mounted anywhere within that range.

IMPORTANT: Air springs will live much longer if they are not the suspension limiter in either compression or extension. Regardless of the load, the air pressure should always be adjusted so that the Normal Ride Height is maintained at all times. The shock absorber is usually the limiter on extension. If this is not the case, you should consider the use of limiting straps, especially if the vehicle is used off-road. The maximum inflated diameter of your air spring is 4.5". You must check to see that nothing is rubbing against the air spring within this diameter.

This drawing represents a typical installation. Your vehicle may look slightly different due to make, model, or year.

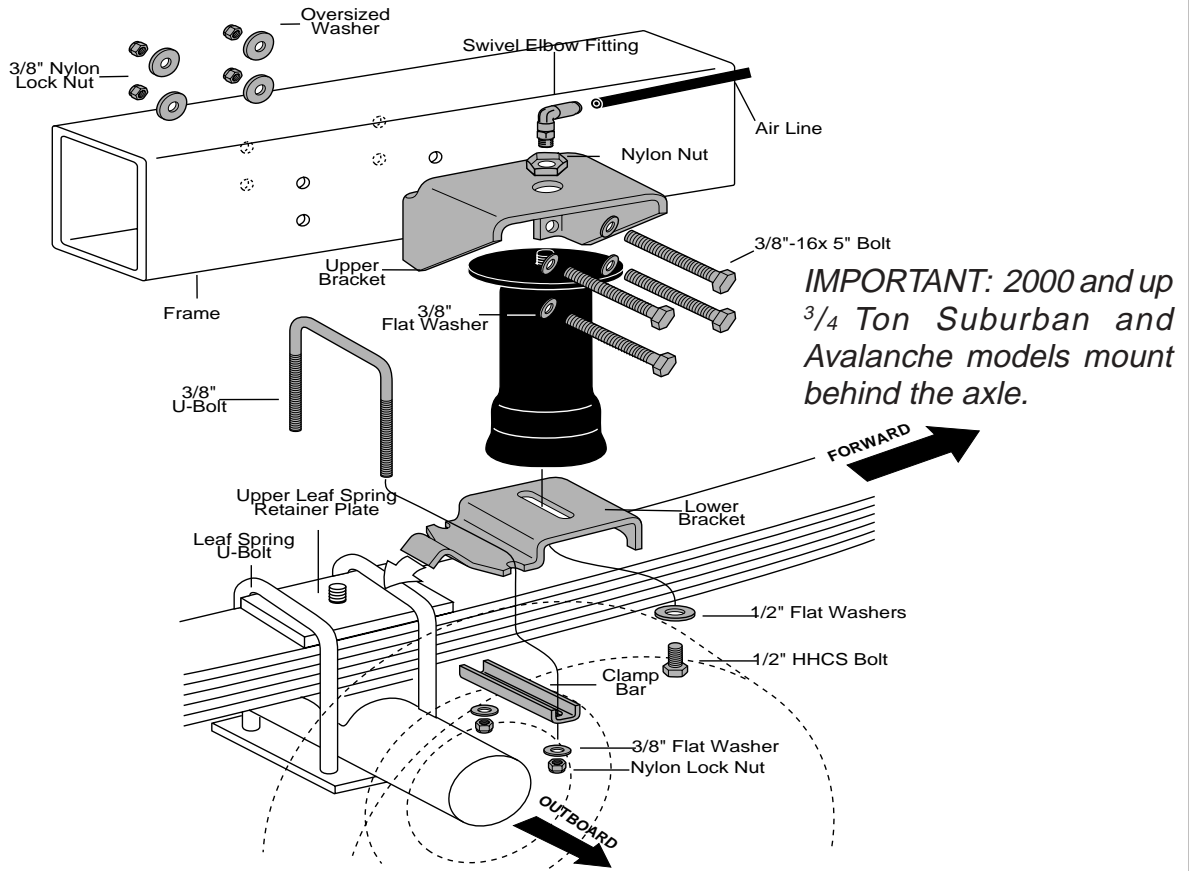

Figure 2

I. Raising the Vehicle

1. Determine the Ride Height. This is defined as the distance between the bottom edge of the fenderwell to the center point of the wheel with the vehicle at the desired height (without a load). Measurements should be taken before beginning the installation. The distance from the bottom edge of the fenderwell to the center point of the wheel should be recorded. All of our kits are designed to be installed and operate at normal ride height.
2. Measure the ride height distance. Enter the measurement below:

Ride Height: _____ inches
3. After measuring and recording the ride height, jack up rear of vehicle or raise on hoist. Raise axle or lower frame until the leaf spring is at ride height (unloaded condition).
4. Measure the distance between the tire and outside of frame rail. You must have a minimum of six (6") inches to provide clearance for the air spring when fully inflated.

II. Using the Installation Tool

1. Place the upper bracket onto the threaded end of the tool and rest the bracket on the bottom Pal nut (flange down). Then thread a nylon nut onto the tool to hold the bracket in place (Figure 1).
2. Use a 1/2" flat washer and the 1/2" x 7/8" bolt to attach the lower bracket to the bottom of the installation tool. Leave just loose enough to adjust in and out (Figure 1).

- Set the preassembled bracket/tool unit on the leaf spring forward of the axle.

IMPORTANT: For 2000 and up $\frac{3}{4}$ Ton Sububan and Avalanche models, mount behind the axle.

- With the hook end of the lower bracket placed over the existing U-bolt or Spring Retainer, secure the lower bracket to the leaf spring with the provided U-bolt, flat washers, and lock nuts. Torque to 16 ft-lbs (Figure 1 and Inset A).
- Using the slot in the lower bracket, push the upper bracket against the frame rail. Use the nuts on the threaded portion of the installation tool to adjust the upper bracket (up and down) so that the flanges of the upper bracket are flat against the frame rail and all four mounting holes are on the flat middle section of the frame rail.

NOTE: Be sure that none of the holes are directly on the radius bend of the frame.

IMPORTANT: There must be at least 1.5" above the upper bracket for air fitting clearance. The brackets can be mounted anywhere within the threaded range of the installation tool (Figure 1).

- CAUTION:** Do not drill holes into the frame until all hydraulic lines, gas lines, and electrical wires have been moved aside on both sides of the frame rail.
- Using the upper bracket as a template, centerpunch one of the lower mounting holes and drill a $\frac{3}{8}$ " hole through the frame.

NOTE: You will need a drill bit with at least 4.25" effective length for boxed frame vehicles.

- Install one of the $\frac{3}{8}$ "-16 x 5" bolts and a $\frac{3}{8}$ " flat washer through the bracket and frame. Then loosely attach the oversized flat washer and locknut on the backside.

NOTE: All Ford vans and Suburbans require $\frac{3}{8}$ "-16 x 1.5" washer head frame bolts for the C-section type frame rail. The oversized washers are not necessary for these vehicles (Figure 3).

- Now centerpunch and drill a $\frac{3}{8}$ " hole at the *opposite lower* mounting hole location. *Do not* insert the mounting bolt at this time.

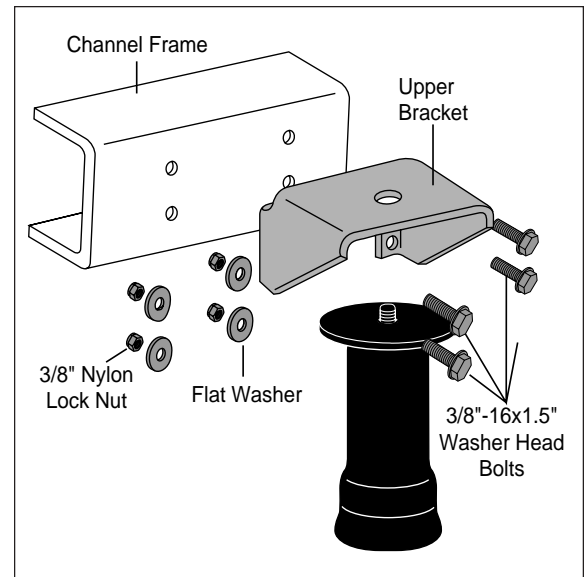

Figure 3

III. Attaching the Upper Bracket

- Remove the installation tool by removing the nylon nut, loosening and removing the tool from the bottom bolt (leave in place), and slightly rotating the upper bracket to allow for enough room to completely remove the tool.

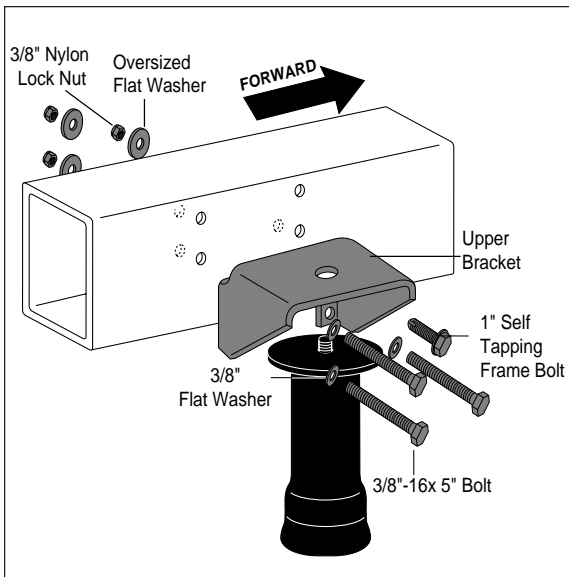

Figure 4

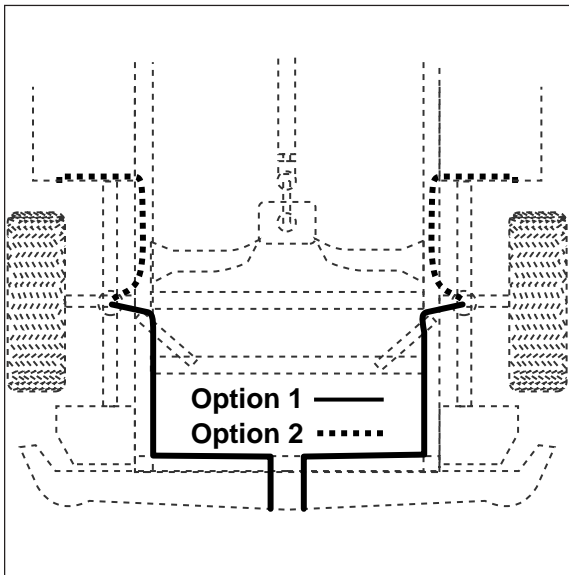

Figure 5

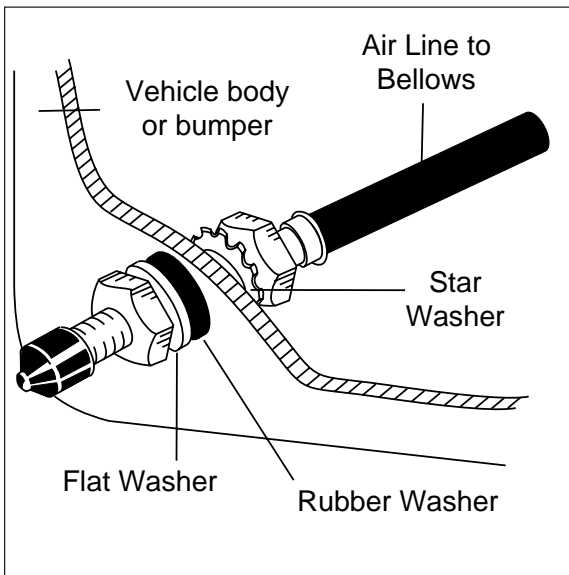

Figure 6

2. Rotate the upper bracket back to the original location and install the frame bolt, flat washer, and lock nut through the second hole previously drilled. Tighten both of the installed fasteners to 20 ft-lbs.
3. Centerpunch and drill the other two holes and insert and install the fasteners (Figure 2). Tighten to 20 ft-lbs.

NOTE: '95 and Older Chevrolet/GMC Vans only require the use of a self tapping frame bolt in the upper forward mounting hole on the passenger side only. Drill a $\frac{5}{16}$ " hole (no larger) for the self taper, but do not install at this time. All other attachments use the $\frac{3}{8}$ " x 5" bolts (Figure 4).

IV. Installing the Sleeve

1. Install the elbow fitting finger tight plus 1 1/2 turns. Use a $\frac{7}{16}$ " open end wrench being careful to tighten on the metal hex nut only. Do not over tighten. This fitting is precoated with thread sealant.
2. Collapse the air spring and guide upper end through the center mounting hole in the upper bracket. Attach the air spring to the lower bracket. Carefully hand turn the air spring onto the lower mounting bolt. Leave loose for later adjustment.
3. Now install the nylon nut onto the upper threadpost of the air spring. Leave loose for final adjustment.

V. Installing the Air Lines

1. Select a location for the inflation valves in the rear bumper area or rocker panel flange ensuring that each valve will be protected and accessible with an air hose (Figure 5).
2. Use a standard tube cutter, a razor blade, or very sharp knife to cut the air line. A clean square cut will ensure against leaks. Cut the air line in two equal lengths. Drill $\frac{5}{16}$ " hole for inflation valve and mount as illustrated. Rubber washer on the outside is for weather seal (Figure 6).
3. Route air line along frame from the inflation valve location to the air springs (Figure 5). Use the tie straps or provided clips and self tapping screws to attach the air line to the frame rail (Figure 7). It is not necessary to drill a hole for this type of self tapping screw. Simply drive the screw through the frame section. Attach air line to chassis with the provided plastic straps.

CAUTION: Leave sufficient air line slack to prevent any strain on the valve stem during normal axle motions.

CAUTION: To prevent air line from melting, keep it at least 12" from the exhaust system.

- Cut off excess air line squarely. Install the air line into the fitting. This is a self locking fitting. Push and slightly turn the cut end of the air line into the fitting as far as it will go. When seated, a click can be heard/felt. The air line should go in $\frac{9}{16}$ ".

VI. Securing the Sleeve

- VERY IMPORTANT:** With the bottom and top still loose, inflate the air spring to approximately 10 p.s.i. By using the slotted adjustment in the lower bracket, align the air spring so that there is a symmetrical cushion of air around the lower base. This can be accomplished by pressing all around the air spring and tapping it inboard or outboard for proper alignment (Figure 7).
- Tighten the upper nylon nut (4 ft-lbs.). *Do not over tighten.*
- Tighten the bolt on the bottom with an open end wrench. *Do not over tighten.*

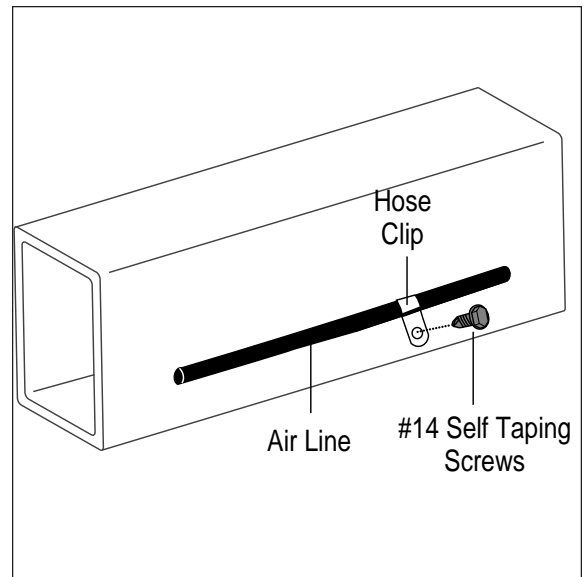

Figure 7

VII. Finishing the Installation

- Inflate to 60 p.s.i. Check all fittings and inflation valve core with a solution of $\frac{1}{5}$ dish soap to $\frac{4}{5}$ water. Check once again to be sure you have clearance all around the air spring at its fully inflated diameter (4.5").
- Installation for one air spring is now complete. Recheck the minimum clearance measurements for the other side and complete sections II through VII for remaining side. Finish with section VII, step 3.
- Recheck air pressure after 24 hours. A 2–4 p.s.i. loss after initial installation is normal. If pressure has dropped more than 5 p.s.i. retest for leaks with the soapy water solution.
- Check to see that the sleeve rolls back down over the bottom piston after the vehicle is lowered (Figure 8 and 9).
- Please read and follow the Maintenance and Operating tips.

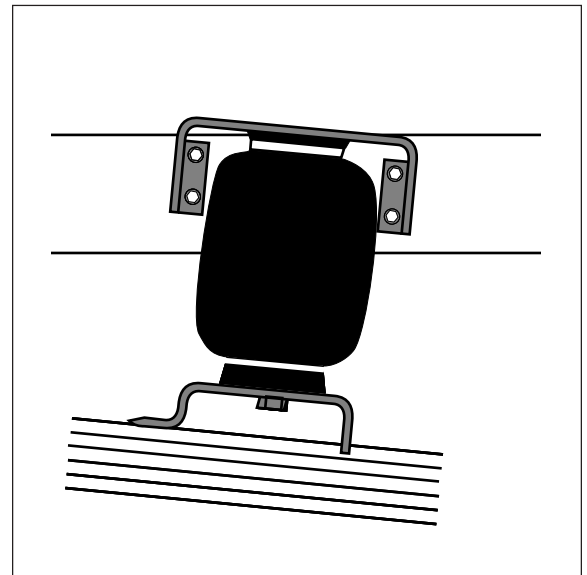

Figure 8

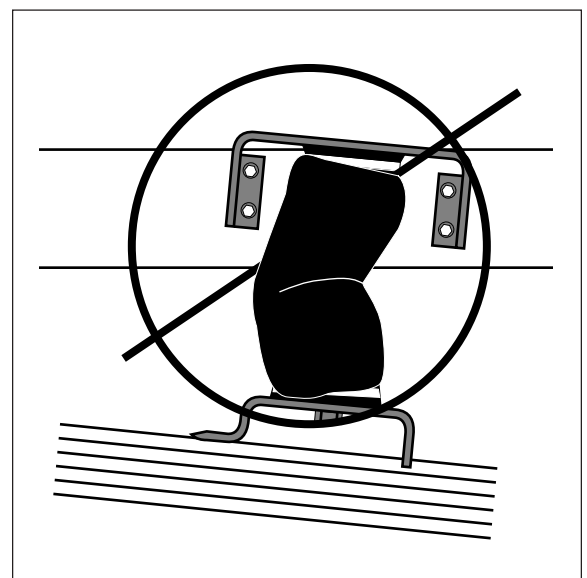

Figure 9

Maintenance and Operations

Minimum Air Pressure	Maximum Air Pressure
5 p.s.i.	100 p.s.i.
<i>Failure to maintain correct minimum pressure (or pressure proportional to load), bottoming out, over-extension, or rubbing against another component will void the warranty.</i>	

By following these steps, vehicle owners will obtain the longest life and best results from their air springs.

1. Check the air pressure weekly.
2. Always maintain at least 5 p.s.i. air pressure.
3. If you develop an air leak in the system, use a solution of $\frac{1}{5}$ dish soap to $\frac{4}{5}$ water to check all air line connections and the inflation valve core before removing sleeve.
4. Inflate your air springs to 60 p.s.i. before adding the payload. After vehicle is loaded, adjust your air pressure to level the vehicle and for ride comfort. When increasing load, always adjust the air pressure to maintain the Normal Ride Height. Increase or decrease pressure from the system as necessary to attain Normal Ride Height for optimal ride and handling. Remember that loads carried behind the axle (including tongue loads) require more leveling force (pressure) than those carried directly over the axle.
5. When carrying a payload it will be helpful to increase the tire inflation pressure in proportion to any overload condition. We recommend a 2 p.s.i. increase above normal (not to exceed tire manufacturer maximum) for each 100 lbs. total overload on the axle.
6. **IMPORTANT:** For your safety and to prevent possible damage to your vehicle, *do not exceed maximum Gross Vehicle Weight Rating (GVWR), as indicated by the vehicle manufacturer.* Although your air springs are rated at a maximum inflation pressure of 100 p.s.i. The air pressure actually needed is dependant on your load and GVWR, which may be less than 100 p.s.i. Check your vehicle owners manual and do not exceed the maximum load listed for your vehicle.
7. Always add air to springs in small quantities, checking the pressure frequently. Sleeves require less air volume than a tire and inflate quickly.
8. *Should it become necessary to raise the vehicle by the frame, make sure the system is at minimum pressure (5 p.s.i.) to reduce the tension on the suspension/brake components.* Check to see that the sleeve rolls back down over the bottom piston after the vehicle is lowered (Figure 8). If sleeve fails to roll back down over the piston, add air pressure until sleeve “pops” back over piston (do not exceed 100 p.s.i.).

Thank you for purchasing Air Lift Products



Mailing Address:
AIR LIFT COMPANY
P.O. Box 80167
Lansing, MI 48908-0167

Street Address:
AIR LIFT COMPANY
2727 Snow Rd.
Lansing, MI 48917

Local Phone: (517) 322-2144
Fax: (517) 322-0240

For Technical Assistance call 1-800-248-0892

“The Choice of the Professional Installer”

Printed in the USA