

Please read these instructions completely before proceeding with the installation.

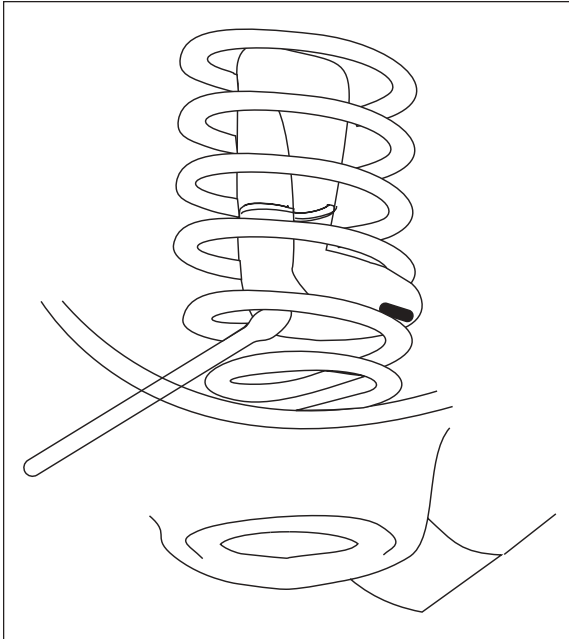

Figure 1

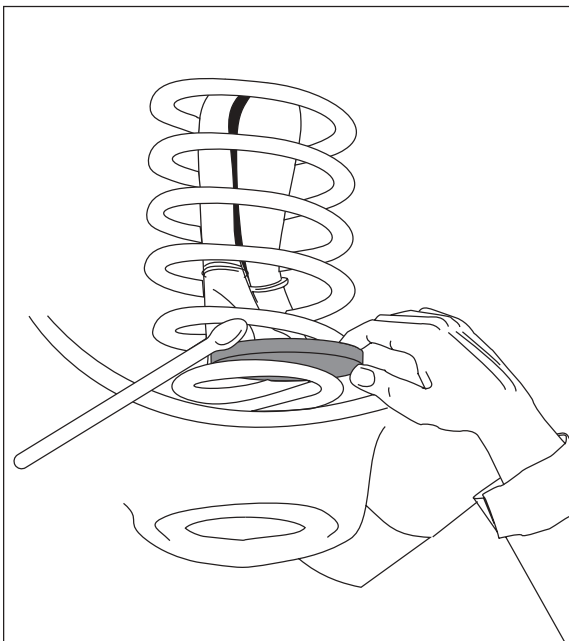

Figure 2

I. Installing the Air Bag

1. Jack up front of vehicle or raise on hoist. Support frame with safety stands. Lower axle or raise body of vehicle until suspension is fully extended.
2. Remove plastic cap from barbed stem on end of cylinder. Exhaust the air from the cylinder by rolling it up toward barbed stem. Replace cap on stem to hold flat shape.
3. If necessary, additional clearance between the coil turns may be obtained by removing the shock absorbers from the lower shock mountings and lowering the suspension an additional one to two inches. CAUTION: Observe tension on the brake hose. Do not strain.
4. Insert flattened air cylinder into coil spring through lowest opening with stem at the bottom (Figure 1).
5. Push the cylinder up within the coil by hand or with a blunt instrument such as a spoon-type tire iron.
6. When the cylinder is completely within the coil, remove the cap and allow the cylinder to assume its "as molded" shape.
7. Push cylinder to the top of the coil and insert protector on top of lower spring seat (Figure 2).

II. Installing the Air Lines

There are two different types of air line installation, tee air line installation and dual air line installation. A tee air line installation is recommended unless weight in vehicle varies from one side to the other and unequal pressures are needed to level load (or compensate for axle torque transfer in racing application). Dual air lines are used in this case.

1. Tee Air Line Installation:

NOTE: To prevent the air line from melting, keep it at least 8" from the exhaust system.

- a. Locate desired tee location on the frame rail or cross member.
- b. Determine and cut adequate length of air line to reach from tee to left and right side on air cylinders. CAUTION: Leave sufficient air line slack to prevent any strain on fitting during axle motions.

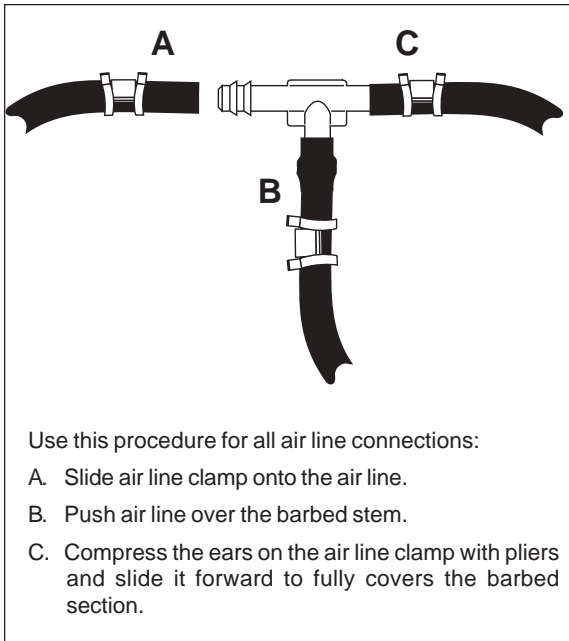

Figure 3

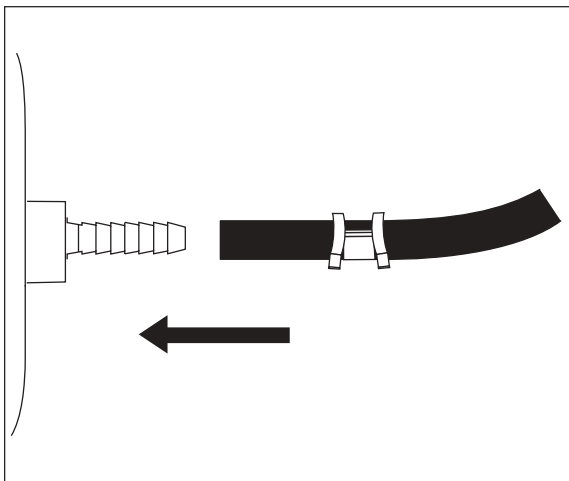

Figure 4

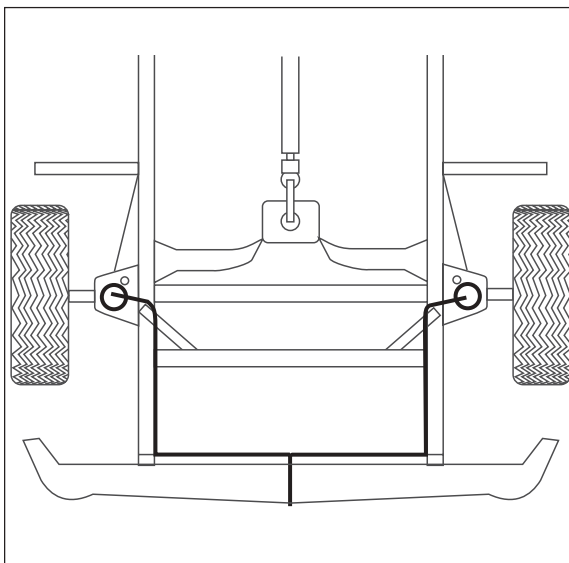

Figure 5

- Slide air line clamp onto the air line. Push the air line over one side of the tee until all the barbs are covered. Repeat procedure for other leg of tee.
- With pliers slide the air line clamp forward until it fully covers the barbed section. Repeat for other leg of tee (Figure 3).
- Route along cross member and either lower control arm or upper spring seat to air cylinder.
- Insert air line through lower spring seat and lower protector, then slide on air line clamp.
- Push the air line onto the stem, covering all the barbs. With pliers slide the air line clamp upward until it fully covers the barbed section (Figure 4).
- Push the remaining air line over the last fitting on tee and route along frame to desired inflation valve location (Figure 5). Attach with plastic straps or wire.
- Select a location for inflation valve in the front bumper, fender flange or behind the license plate, assuring that the valve will be protected and accessible with an air hose (Figure 5).
- Drill a $\frac{5}{16}$ " hole for inflation valve and mount as in illustration (Figure 7). Rubber washer is for outside weather seal.
- Slide air line clamp over the air line. Push air line onto fitting covering all barbs, with pliers slide the air line clamp forward until it fully covers the barbed section (Figure 5).
- Raise axle or lower body until air cylinders lightly touch upper spring seat and lower protectors. NOTE: Attach shock absorbers if removed earlier in the installation.
- Continue by reading sections III and IV. IMPORTANT: Do not inflate the air springs until first reading the maintenance and operation tips (Section IV).

2. Dual Air Line Installation:

NOTE: To prevent the air line from melting, keep it at least 8" from the exhaust system.

- Select a location for the inflation valves in the rocker panel flange, or front bumper, assuring that each valve will be protected and accessible with an air hose (Figure 8).
- Determine and cut adequate length of air line to reach from valve location to left side air cylinder. CAUTION: Leave sufficient air line slack to prevent any strain on fitting during axle motions.

- c. Insert the air line through the lower spring seat and lower protectors.
- d. Slide air line clamp onto the cut air line. Push the air line onto the stem, covering all the barbed section. With pliers slide the air line clamp forward until it fully covers barbed section (Figure 4).
- e. Repeat process for right side.
- f. Drill $\frac{5}{16}$ " hole for inflating valves and mount as illustrated. Rubber washer is for outside weather seal (Figure 7).
- g. Route air line along control arm and frame to inflation valve location and cut off excess air line.
- h. Slide air line clamp onto the air line and push the air line over the fitting, covering all the barbs. With pliers slide the air line clamp forward until it fully covers the barbed section.
- i. Raise axle or lower body until air cylinders lightly touch upper spring seat and lower protectors. NOTE: Attach shock absorbers if removed earlier in the installation.
- j. Continue by reading sections III and IV. IMPORTANT: Do not inflate the air springs until first reading the maintenance and operation tips (Section IV).

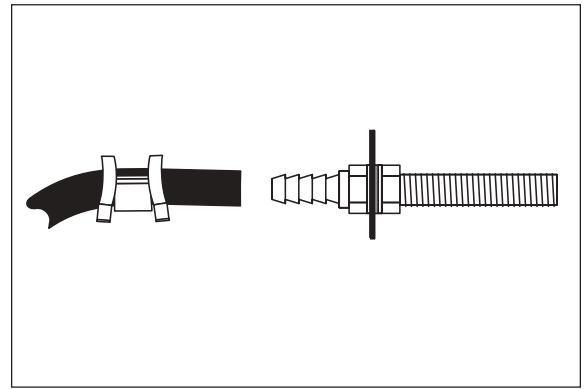

Figure 6

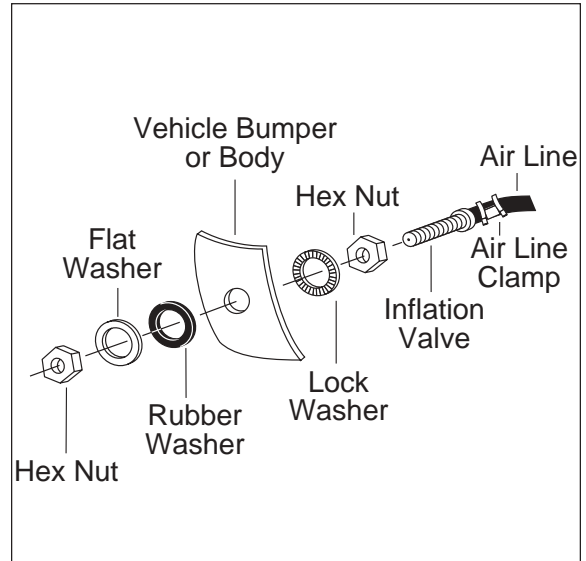

Figure 7

III. Checking the System

1. Inflate cylinders to 30 p.s.i. air pressure.
2. Test for air leaks by applying a solution of $\frac{1}{5}$ dish soap to $\frac{4}{5}$ water in a spray bottle to all valve cores, fittings and connections.
3. Lower vehicle to the ground. Read Maintenance and Operation Tips for proper care of the Air Lift 1000 kit.

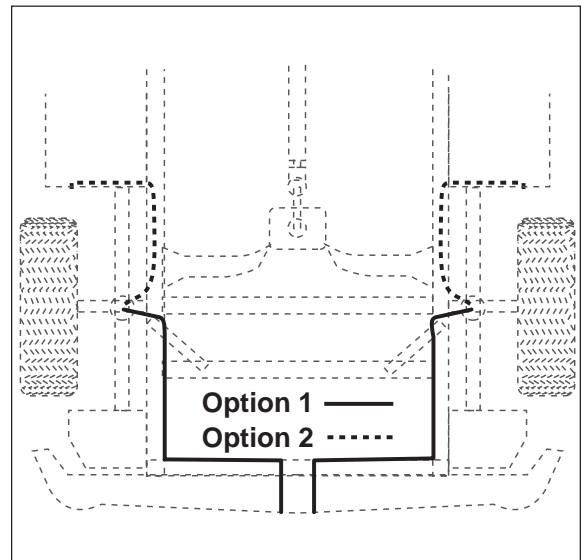

Figure 8

IV. Maintenance and Operations

Minimum Air Pressure	Maximum Air Pressure
5 p.s.i.	35 p.s.i.
<i>Failure to maintain correct minimum pressure (or pressure proportional to load), bottoming out, over-extension, or rubbing against another component will void the warranty.</i>	

By following these steps, vehicle owners will obtain the longest life and best results from their air springs.

MAINTENANCE TIPS:

1. Check pressure weekly.
2. Always maintain at least 5 p.s.i. air pressure to prevent chafing or coil pinch.
3. If a leak develops in the system, use a soapy/water solution to check all air line connections and the valve core before removing cylinder.

OPERATING TIPS:

1. Inflate your air springs to 30 p.s.i. before adding the payload. This will allow the air cylinder to properly mesh with the coil spring. After vehicle is loaded, adjust your air pressure (down) to level the vehicle and for ride comfort.
2. When you are carrying a payload it will be helpful to increase the tire inflation pressure in proportion to any overload condition. We recommend a 2 p.s.i. increase above normal (not to exceed tire manufacturers maximum) for each 100 lbs. additional load on the axle.
3. **IMPORTANT:** For your safety and to prevent possible damage to your vehicle, *do not exceed maximum Gross Vehicle Weight Rating (GVWR), as indicated by the vehicle manufacturer.* Although your air springs are rated at a maximum inflation pressure of 35 p.s.i. The air pressure actually needed is dependant on your load and GVWR, which may be less than 35 p.s.i. Check your vehicle owners manual and do not exceed the maximum load listed for your vehicle.



Thank you for purchasing Air Lift Products

Mailing Address:
AIR LIFT COMPANY
P.O. Box 80167
Lansing, MI 48908-0167

Street Address:
AIR LIFT COMPANY
2710 Snow Rd.
Lansing, MI 48917

Local Phone: (517) 322-2144
Fax: (517) 322-0240

For Technical Assistance call 1-800-248-0892, extension 2

“The Choice of the Professional Installer”

Printed in the USA