



Installation Instructions

Supertop® Replacement Skin

with Tinted Side and Rear Windows



Does Not Include Hardware

Vehicle Application

• Jeep CJ7
1976 – 1986
Hard Door Models
Part Number: 55729

• Jeep Wrangler/YJ
1986 – 1995
Hard Door Models
Part Number: 55729

www.Bestop.com - We're here to help! Visit our web site and click on ["Ask a Question"](#). Click here for more [Jeep Accessories by Bestop](#).

INSTALLATION TIME	SKILL LEVEL
 45 Minutes	 2 - Moderately Easy

TOOLS
 Safety Glasses

Replacement for:
 51598 – Top Deck, Side Panels and Rear Curtain Only
 51599 – Top Deck, Side Panels and Rear Curtain Only
 51600 – Top Deck, Side Panels and Rear Curtain Only
 51603 – Top Deck, Side Panels and Rear Curtain Only



 **CAUTION** Safety glasses should be worn at all times while installing this product.

Installation Tips
 Before you begin installing this assembly, read all instructions thoroughly.
For a smooth fit:
 For ease in installation, the product should be installed at temperatures above 72° F. Below this temperature, the fabric may contract an inch or more, making it difficult to fit to the vehicle. It is normal for fabric to contract and wrinkle when stored in the shipping carton. Within a few days after the installation, the fabric will relax and the wrinkles will disappear.

 **WARNING** This product is designed primarily to enhance the appearance of the vehicle and to shield the occupants from ordinary weather conditions. Do not rely in any way on the components of this product to contain occupants within the vehicle, or to protect against injury or death in the event of an accident. This product will not protect the occupants from falling objects. Never operate the vehicle in excess of manufacturer's specifications.

WEAR SEAT BELTS AT ALL TIMES

Read and follow, precisely, all installation instructions provided when installing product. Failure to do so may result in a poor fit and could place occupants of the vehicle in a potentially dangerous situation.

Supertop® Replacement Skin – Installation Instructions

Parts List

Top Fabric	Qty - 1
Quarter Window, Right	Qty - 1
Quarter Window, Left	Qty - 1
Rear Window	Qty - 1

1 Install Top on Vehicle

Locate the top and orient it on the vehicle. Drape the top over the bows and insert the plastic strip sewn along the front of the top into windshield retainer attached on the front of the windshield frame. Center the front of the deck on the vehicle so that it is an equal distance from the top of the windshield flange on both sides.

NOTE For best possible installation, check to make sure that the soft top is perfectly centered on the vehicle.

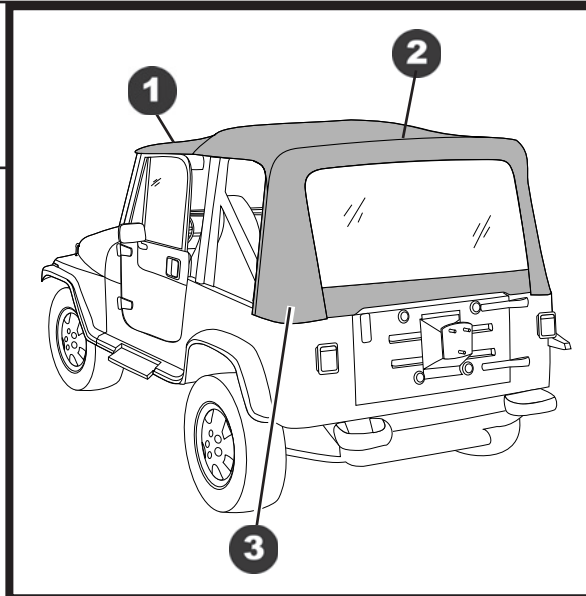
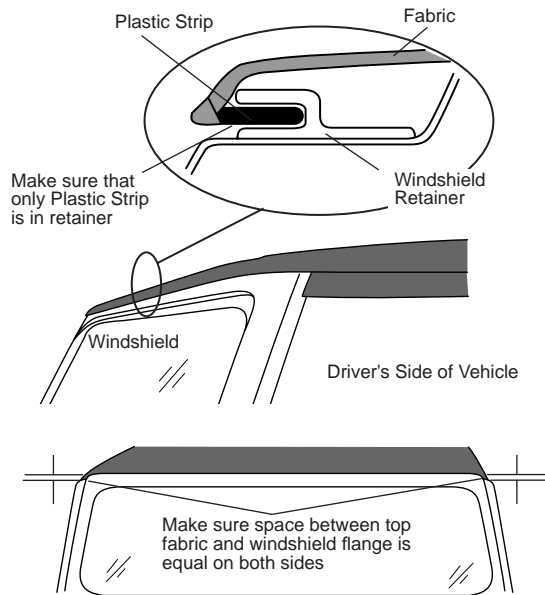

2 Snap Top to Rear Bow

Snap the flaps to the six studs on the rear bow.

NOTE If the snaps don't appear to line up, push the rear bow forward to relieve the pressure on the bow. This will allow the snaps to line up more easily.

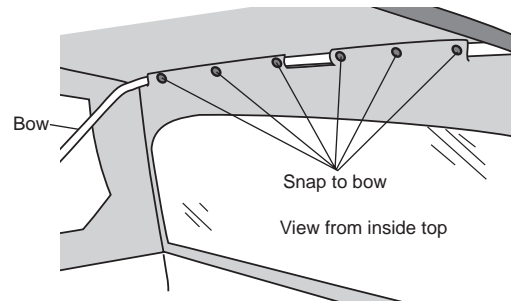

3 Secure Rear Corners

Insert the black plastic strips at rear corners of top into Corner Belt Rails. There is a plastic reinforcement sewn into the corner of the top, in addition to the plastic strip.

Make sure that the reinforcement is not caught under the Corner Belt Rail.

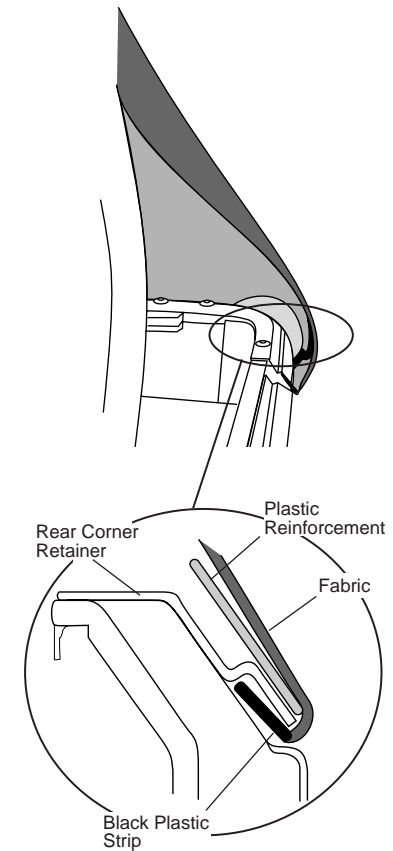

Supertop® Replacement Skin – Installation Instructions

4 Raise the Rear Bow

Slide the Rear Bow up on the Front Bow and insert the small bent tab into one of the four holes in the Front Bow.

NOTE If the top is extremely tight, slip the tab into the bottom hole. The top will loosen up after a few hours in the sun. Then the tab may be inserted into a higher hole position.

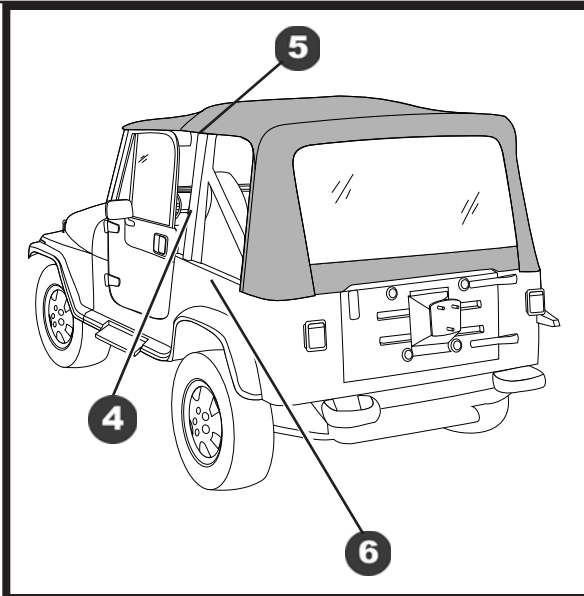
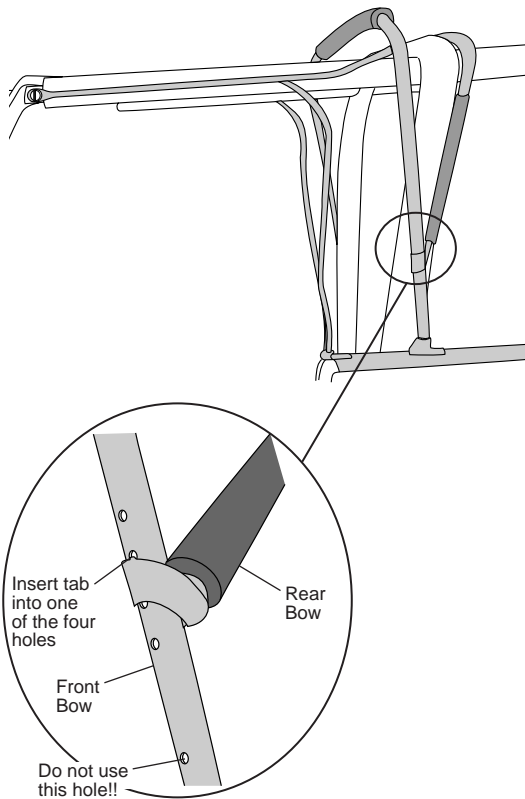

5 Install Side Curtain

Start top and rear zippers on side curtain 6 inches.

NOTE If necessary, release the Bow Coupler and slide the top around the Corner Belt Rail towards the window to make it easier to start the zippers on the Side Curtains.

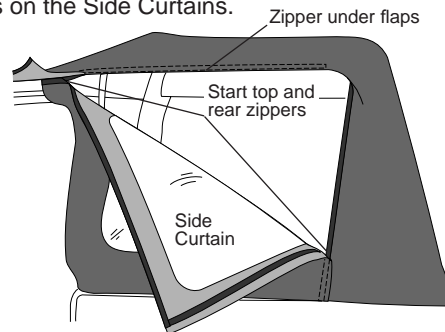

6 Secure Bottom of Side Curtain

Slip the plastic strip on the bottom of the side curtain into the side retainer. Close the top zipper on the side curtain.

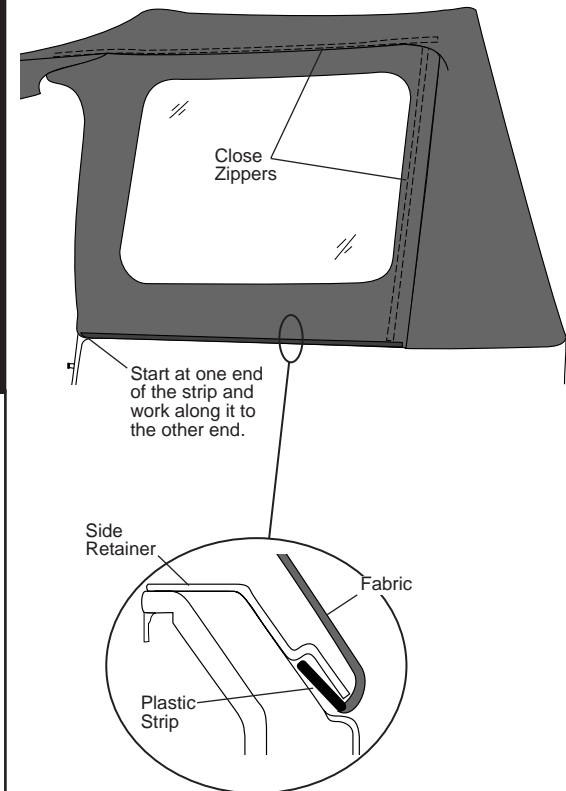

Supertop® Replacement Skin – Installation Instructions

7 Secure Front of Side Curtain

Wrap fabric flap on the front of the side curtain around the Vertical Rod (not the front bow) and fasten the hook and loop strips to each other.

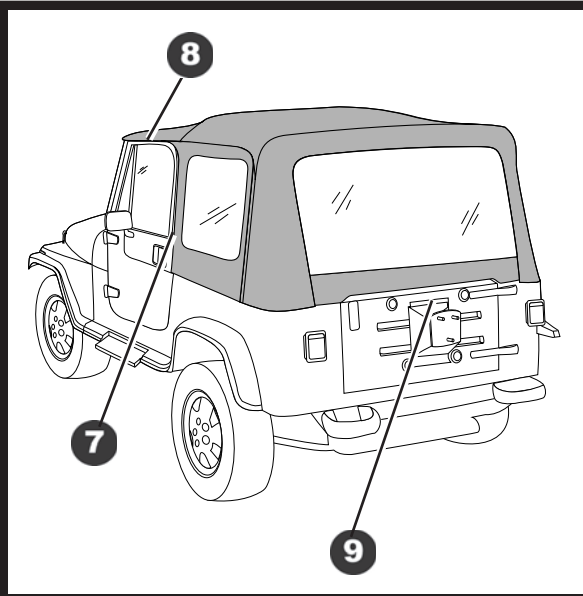
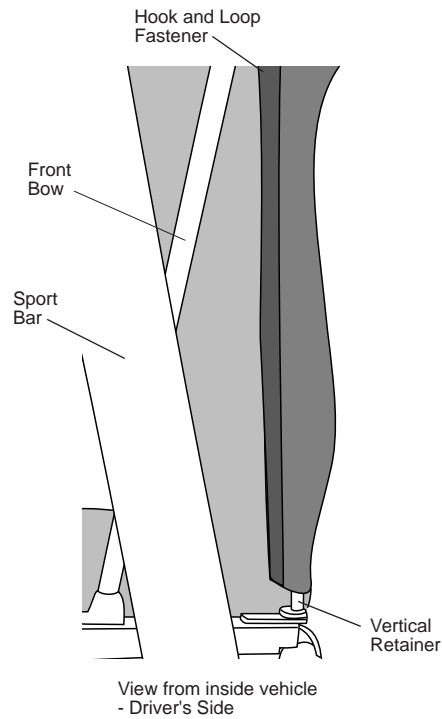

8 Secure Door Flaps

Wrap the flap, sewn to the top above each door, around the Horizontal Rod and fasten the hook and loop strips to each other.

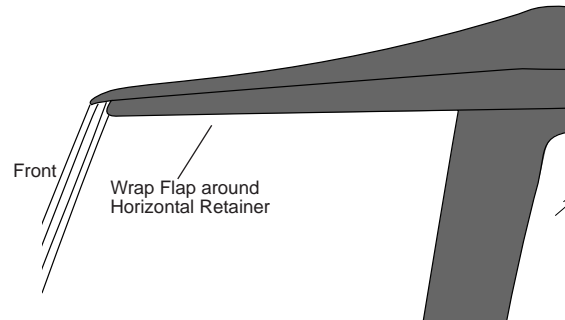

9 Install Rear Curtain Retainer

Open the tailgate. Orient the Rear Curtain Retainer with the rubber bulb facing down, in order to form a seal with the top of the tailgate. Slide the groove in the Rear Curtain Retainer onto the tube inside the bottom of the Rear Curtain. Roll the Rear Curtain Retainer into the top of the Corner Belt Rail. Slip the plastic on the bottom of the corners under the bottom of the Corner Belt Rail. Close the rear curtain zippers.

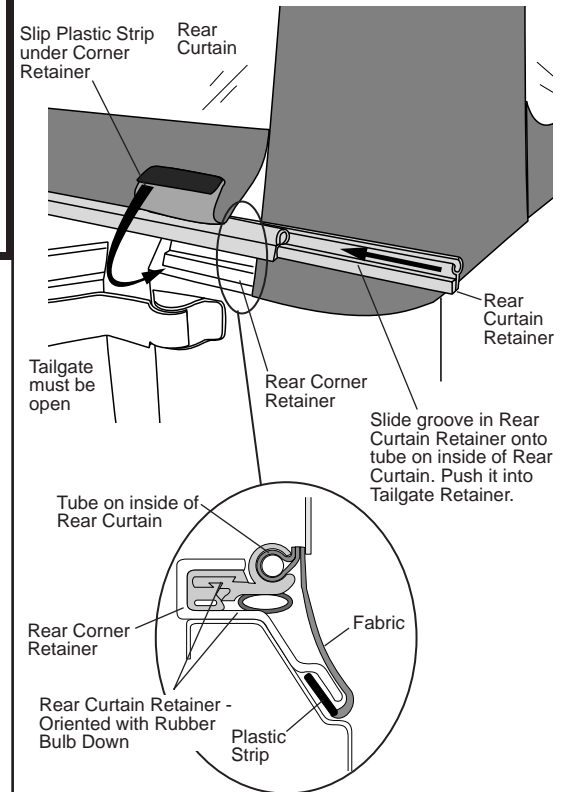

Supertop® Replacement Skin – Installation Instructions



WARNING

When operating the vehicle without the Side Curtains, the Rear Curtain should be rolled up for proper ventilation.

10 Adjusting the Top

Side Curtains

To remove the Side Curtains. Unzip the rear and top zippers. Release the plastic strip from the retainer. Release the Hook and Loop Fasteners from around the Vertical Retainer.

Rear Curtain

To roll up the Rear Curtain, remove the Rear Curtain Retainer and start at the bottom, rolling it to the inside. Avoid wrinkles in the fabric and window. Secure it in place with the curtain straps inside of the top.

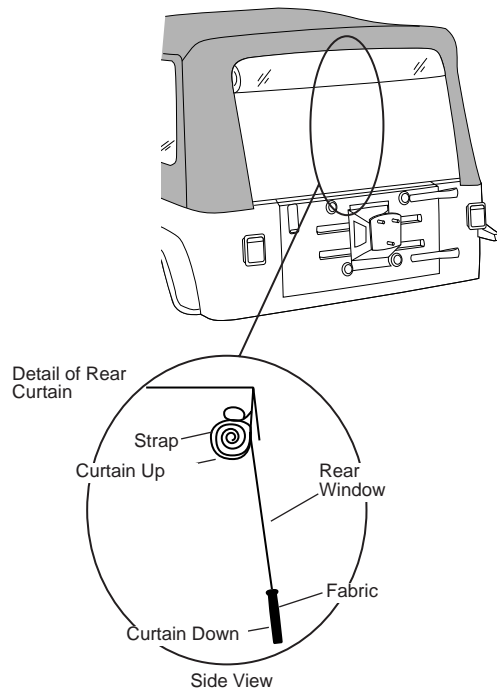

11 Folding the Top Down

Open the zippers at the rear of the Side Curtains. Pull the plastic strip on the bottom of the Side Curtains out of the Belt Rails. Leave the rear corners of the top attached to the Corner Belt Rails. Unfasten the hook and loop strips at the front of the Side Curtains, releasing the Side Curtains from the Vertical Retainer. Fold the Side Curtains up onto the top and release the hook and loop fasteners on the flaps, above the doors. Unsnap the top from the rear bow.

Release the locking tabs on the Bow Releases from the holes in the bow and slide the rear bow down to the Bow Mounts. Release the Horizontal Rod from the Windshield Bracket. Remove the Vertical Rod from the Vertical Retainer Mount and lay the bow assembly down on the rear of the vehicle.

Unfasten the top from the windshield and lay it down on the body. Make sure that the rear corners of the top are tucked under the rear bow. Fold the top in half from front to back and continue folding until the top is about 1 foot wide at the rear of the vehicle. Secure the top by clipping the Bow Tie Downs into the Side Belt Rails.

12 Removal of Soft Top for Open Air Driving

When operating the vehicle with the fabric top removed, it is very important that the supporting hardware system be disconnected from the windshield bracket and folded flat to the rear of the vehicle. The vertical and horizontal rods should be snapped into the plastic clips located on the inside of both bow mount brackets. Wrap the elastic straps around the bows and insert the plastic strip into the side belt rail. Never operate the vehicle with the fabric removed and the hardware in the fully erected position.

Supertop® Replacement Skin – Installation Instructions

Care and Maintenance of your Bestop Product

Your Bestop product is made of the finest materials available. To keep it looking new and for the maximum possible wear, it will need periodic cleaning and maintenance.

Washing: The fabric should be washed often using soap, warm water and a soft bristle brush. Rinse with clear water to remove all traces of soap or use Bestop-recommended Bestop Cleaner and Bestop Protectant. Bestop Cleaner and Bestop Protectant are specially formulated to provide a total cleaning and protection system. Bestop Cleaner will not harm vehicle finish, is biodegradable and environmentally friendly. Bestop Protectant protects against UV-fading, cracking and hardening.

Windows: Keep windows clean to avoid scratching. DO NOT use a brush on the windows! Wash with a water-soaked cloth or sponge and a mild dishwashing detergent or use Bestop-recommended Bestop Vinyl Window Cleaner, which safely cleans and protects vinyl windows while helping prevent UV damage. NEVER WIPE THE WINDOWS WHEN THEY ARE DRY. Be careful when cleaning snow or frost from the vinyl windows since they are easily scratched and may crack at low temperatures. DO NOT roll the sides or rear window in cold weather. The windows become stiff and will crack.

Zippers: Keeping the zipper cleaned and lubricated with a silicone lubricant will help prevent damage and keep the zippers in a smooth working condition. If a zipper opens behind the slider, the slider may have been spread apart. This problem can usually be repaired by using an ordinary pair of pliers to bring the sides back into parallel. Return slider to the end of the zipper in the normal Open position. Squeeze lightly at first and test the zipper. If the zipper continues to remain open squeeze more firmly with the pliers and try the zipper again. Repeat this procedure until the zipper operates correctly.

Water: Seeping through at the seams may be stopped by applying 3-M Scotchgard® on the inside of the seams. Rips in the fabric may be repaired with Bondex® iron on patches. Iron the patches to the Inside of the top, carefully following the Bondex® instructions.

Snaps: Keep snaps cleaned and lubricated with silicone to help prevent snaps from sticking to the studs. If a snap does become stuck to a stud, use a screwdriver and GENTLY pry apart to prevent permanent damage to the snap or the top fabric.

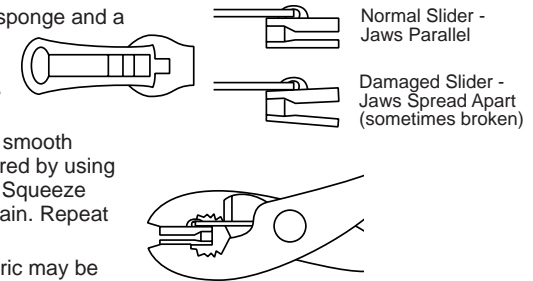

LIMITED WARRANTY

We warrant our product to be free from defects in material and workmanship, for the terms specified below, provided there has been normal use and proper maintenance. This warranty applies to the original purchaser only. All remedies under this warranty are limited to the repair or replacement of any item or items found by the factory to be defective within the time period specified. If you have a warranty claim, first you must call our factory at the number below for instructions. You must retain proof of purchase and submit a copy with any items returned for warranty work. Upon completion of warranty work, if any, we will return the repaired or replaced item or items to you freight prepaid. Damage to our products caused by accidents, fire, vandalism, negligence, misinstallation, misuse, Acts of God, or by defective parts not manufactured by us, is not covered under this warranty.

THE WARRANTY TIME PERIOD IS AS FOLLOWS FOR REPLACE-A-TOP™, SAILCLOTH REPLACE-A-TOP™, SUPERTOP®, SUPERTOP® REPLACEMENT SKINS, SUNRIDER®, AND TIGERTOP®: TWO YEARS FROM DATE OF PURCHASE.

THE WARRANTY TIME PERIOD IS AS FOLLOWS FOR ALL OTHER "SOFT GOODS" MANUFACTURED BY OUR COMPANY (USING PRIMARILY VINYL, PLASTICS, AND/OR FOAM): ONE YEAR FROM DATE OF PURCHASE.

THE WARRANTY TIME PERIOD IS AS FOLLOWS FOR ALL OTHER "HARD GOODS" MANUFACTURED BY OUR COMPANY (USING PRIMARILY METALS, PLASTICS, AND/OR FIBERGLASS): ONE YEAR FROM DATE OF PURCHASE.

ANY IMPLIED WARRANTIES OF MERCHANTABILITY AND/OR FITNESS FOR A PARTICULAR PURPOSE CREATED HEREBY ARE LIMITED IN DURATION TO THE SAME DURATION AND SCOPE AS THE EXPRESS WRITTEN WARRANTY. OUR COMPANY SHALL NOT BE LIABLE FOR ANY INCIDENTAL OR CONSEQUENTIAL DAMAGE.

Some states do not allow limitations on how long an implied warranty lasts, or the exclusion or limitation of incidental or consequential damages, so the above limitations or exclusions may not apply to you. This warranty gives you specific legal rights, and you may also have other rights which vary from state to state.



For further information or request for warranty work, please contact:

Bestop Inc., Customer Service
Toll-Free: (800)845-3567
Main: (303)465-1755
E-mail: csbestop@Bestop.com
Website: www.Bestop.com