







# Installation Instructions Windjammer™

## Vehicle Application

- Jeep JK Wrangler  
2007  
Part Number: 80031

[www.Bestop.com](http://www.Bestop.com) - We're here to help! Visit our web site and click on ["Ask a Question"](#). Click here for more [Jeep Accessories by Bestop](#).

INSTALLATION TIME	SKILL LEVEL
 1/2 Hour	 1 - Easy

TOOLS	
 Safety Glasses	 Torx Wrench
<b>T30</b>	





### Installation Tips

Before you begin installing this assembly, read all instructions thoroughly.

#### For a smooth fit:

For ease in installation, the product should be installed at temperatures above 72° F. Below this temperature, the fabric may contract an inch or more, making it difficult to fit to the vehicle. It is normal for fabric to contract and wrinkle when stored in the shipping carton. Within a few days after the installation, the fabric will relax and the wrinkles will disappear.

 **CAUTION** Safety glasses should be worn at all times while installing this product.

 **WARNING** This product is designed primarily to enhance the appearance of the vehicle and to shield the occupants from ordinary weather conditions. Do not rely in any way on the components of this product to contain occupants within the vehicle, or to protect against injury or death in the event of an accident. This product will not protect the occupants from falling objects. Never operate the vehicle in excess of manufacturer's specifications.

#### WEAR SEAT BELTS AT ALL TIMES

Read and follow, precisely, all installation instructions provided when installing product. Failure to do so may result in a poor fit and could place occupants of the vehicle in a potentially dangerous situation.

# Windjammer™ – Installation Instructions

## Parts List

Windjammer™

Qty - 1

### 1 Remove Rear Window

Open zipper on Rear Window. Pull the Tailgate Bar out of the mounts on the vehicle. Slide the Tailgate Bar off the Rear Window and set it aside to be used later.

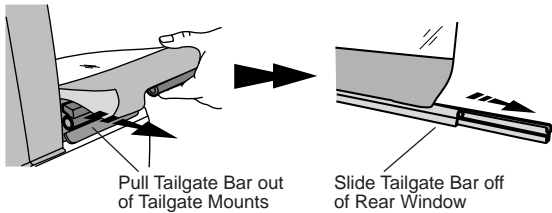

### 2 Fold the Top Down

Release the front of the top from the windshield and lay the bows down. Refer to owner's manual for instructions.

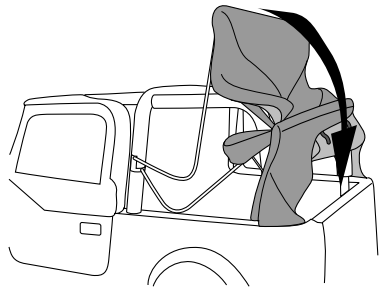

### 3 Wrap Fabric around Bows

Wrap the top fabric tightly around the bows. Then wrap the legs tightly around the top fabric.

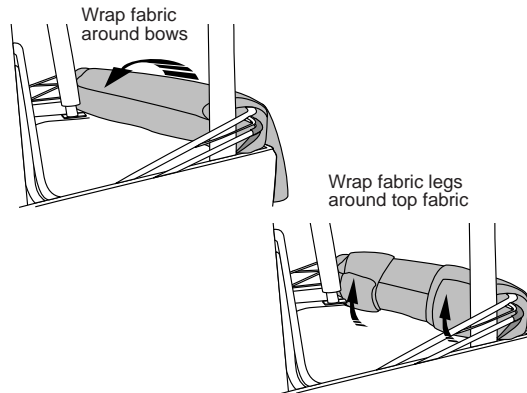

### 4 Remove Top Assembly

Use a T30 Torx to remove the soft top assembly.

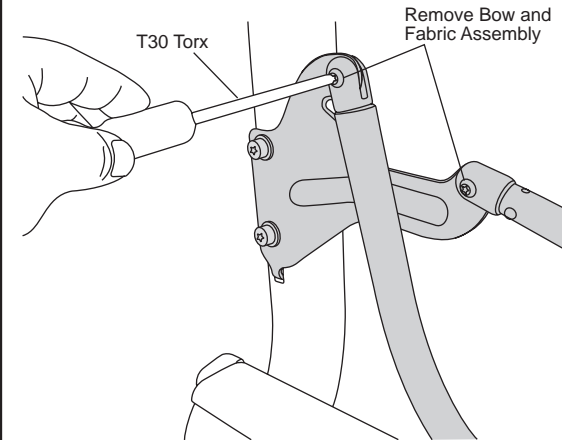

### 5 Remove Pivot Brackets

Use a T30 Torx to remove the main Pivot Brackets on both sides of the vehicle.

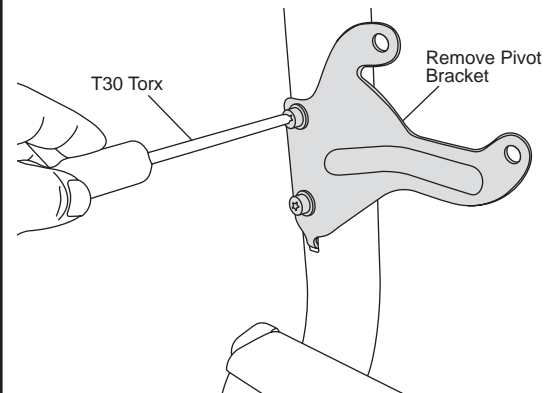

# Windjammer™ – Installation Instructions

## 6 Secure Windjammer™ to Top Sport Bar

Orient the Windjammer™ with the window toward the top and with the vinyl side out. Start with the top straps and thread the end of each strap around the sport bar and through each buckle. Loosely tighten each strap to hold the Windjammer™ in position.

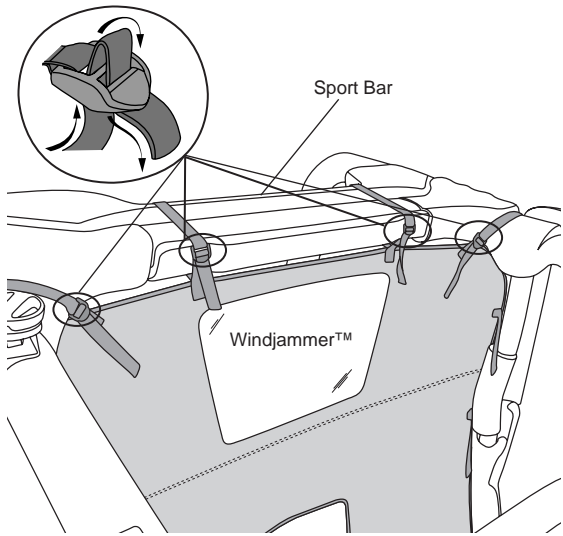

## 7 Secure Windjammer™ to Side Sport Bars

Thread the side straps loosely around the side sport bars.

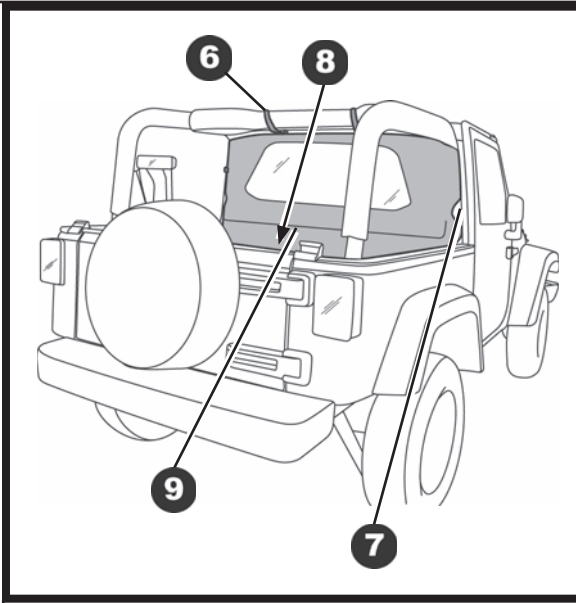
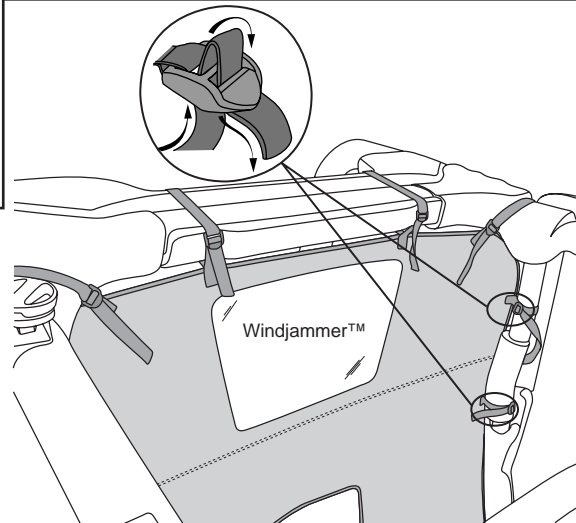

## 8 Secure Windjammer™ to Seat Brackets

Pull down gently on the fabric and thread the straps through the back of the seat brackets. Buckle the straps.

Tighten all straps.

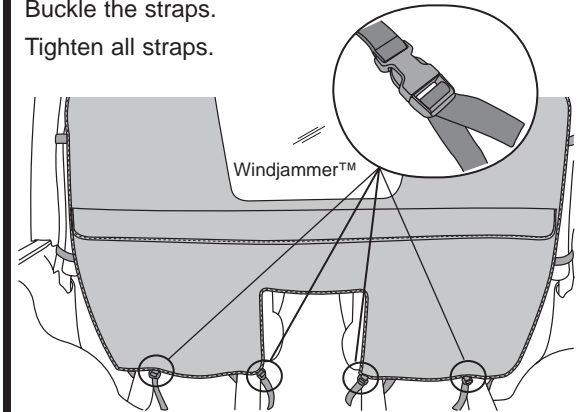

## 9 Secure Windjammer™ to Duster™ Deck Cover – Optional

If you have a Duster™ Deck Cover on your vehicle, attach it to zipper under the flap on the Windjammer™.

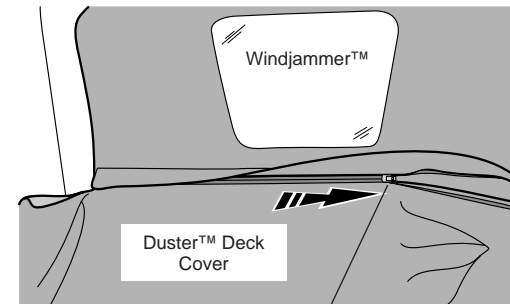

Zip Duster™ Deck Cover to Windjammer™

## Windjammer™ – Installation Instructions

---

### Care and Maintenance of your Bestop Windjammer™

Your Windjammer™ is made of the finest materials available. To keep it looking new and for the maximum possible wear, it will need periodic cleaning and maintenance.

**Washing:** The fabric should be washed often using soap, warm water and a soft bristle brush. Rinse with clear water to remove all traces of soap.

**Windows:** Keep windows clean to avoid scratching. DO NOT use a brush on the windows! Wash with a watersoaked cloth or sponge and a mild dishwashing detergent. NEVER WIPE THE WINDOWS WHEN THEY ARE DRY. Be careful when cleaning snow or frost from the vinyl windows since they are easily scratched and may crack at low temperatures. DO NOT roll the sides or rear window in cold weather. The windows become stiff and will crack.

**Water:** Seeping through at the seams may be stopped by applying 3-M Scotchgard® on the inside of the seams. Rips in the fabric may be repaired with Bondex® iron on patches. Iron the patches to the Inside of the top, carefully following the Bondex® instructions.

---

### Limited Warranty

We warrant our product to be free from defects in material and workmanship, for the terms specified below, provided there has been normal use and proper maintenance. This warranty applies to the original purchaser only. All remedies under this warranty are limited to the repair or replacement of any item or items found by the factory to be defective within the time period specified.

If you have a warranty claim, first you must call our factory at the number below for instructions. You must retain proof of purchase and submit a copy with any items returned for warranty work. Upon completion of warranty work, if any, we will return the repaired or replaced item or items to you freight prepaid. Damage to our products caused by accidents, fire, vandalism, negligence, misinstallation, misuse, Acts of God, or by defective parts not manufactured by us, is not covered under this warranty.

THE WARRANTY TIME PERIOD IS AS FOLLOWS: ALL "SOFT GOODS" MANUFACTURED BY OUR COMPANY (USING PRIMARILY VINYL, PLASTICS, AND/OR FOAM): ONE YEAR FROM DATE OF PURCHASE.

ANY IMPLIED WARRANTIES OF MERCHANTABILITY AND/OR FITNESS FOR A PARTICULAR PURPOSE CREATED HEREBY ARE LIMITED IN DURATION TO THE SAME DURATION AND SCOPE AS THE EXPRESS WRITTEN WARRANTY. OUR COMPANY SHALL NOT BE LIABLE FOR ANY INCIDENTAL OR CONSEQUENTIAL DAMAGE.

Some states do not allow limitations on how long an implied warranty lasts, or the exclusion or limitation of incidental or consequential damages, so the above limitations or exclusions may not apply to you.

This warranty gives you specific legal rights, and you may also have other rights which vary from state to state.



For further information or request for warranty work, please contact:

Bestop Inc. Customer Service

(800) 845-3567

(303) 465-1755