



AEROMOTIVE
Part # 14137
'04-'06 Subaru STI Fuel Rail Kit
INSTALLATION INSTRUCTIONS

CAUTION:

Installation of this product requires detailed knowledge of automotive systems and repair procedures. We recommend that this installation be carried out by a qualified automotive technician.

Installation of this product requires handling of gasoline. Ensure you are working in a well ventilated area with an approved fire extinguisher nearby. Extinguish all open flames, prohibit smoking and eliminate all sources of ignition in the area of the vehicle before proceeding with the installation.

When installing this product, wear eye goggles and other safety apparel as needed to protect yourself from debris and sprayed gasoline.

WARNING!

The fuel system is under pressure. Do not open the fuel system until the pressure has been relieved. Refer to the appropriate vehicle service manual for the procedure and precautions for relieving the fuel system pressure.

The enclosed Aeromotive fuel rails utilize o-ring sealed AN-08 style ports; these ports are **NOT PIPE THREAD** and utilize **NO THREAD SEALANT**. To use the enclosed fuel rails in your vehicle's fuel system you must install the necessary adapter fittings and o-rings, high pressure fuel lines and regulator to adapt your system to the configuration and ports of these fuel rails. Please call for a catalog of the complete line of quality Aeromotive products.

The enclosed Aeromotive fuel rails are intended to be installed on an unmodified OEM intake manifold of the identified application. Aeromotive cannot guarantee the proper fitment on aftermarket intake manifolds and the end user is responsible for verifying proper fitment and assumes all liability.

When installing o-rings it is important to place a small amount of light oil on both the o-ring and the mating surface to ease installation and prevent damaging the o-ring.

The following installation instructions are for a typical installation, for specific year and model installation instructions please refer to your vehicles service manual.

Aeromotive system components are not legal for sale or use on emission controlled motor vehicles.

Special tools needed:

Fuel line quick disconnect tool

Supplies needed:

Vehicle service manual
Fuel injector replacement O-rings
Light oil
Solvent parts cleaner
Clean shop towels

This kit contains the following parts:

1ea p/n 14136 Subaru STI 2.5L Fuel Rails
1ea p/n 13101 A1000 EFI Regulator
1ea p/n 15119 Supply Tee Adapter Fitting
2ea p/n 15635 AN-06 to 5/16" Barb Fitting
1ea p/n 15606 ORB-06/AN-06 Port Fitting
3ea p/n 15607 ORB-08/AN-08 Port Fitting
2ea p/n 15610 ORB-10/AN-08 Port Fitting
2ea ORB-06 O-Ring
4ea ORB-08 O-Ring
2ea ORB-10 O-Ring

2ea p/n 15618 ORB-08 Slim Line Port Plug
1ea p/n 15650 AN-06 Straight Hose End
1ea p/n 15652 AN-06 90-Degree Hose End
1ea p/n 15653 AN-08 Straight Hose End
1ea p/n 15654 AN-08 45-Degree Hose End
5ea p/n 15655 AN-08 90-Degree Hose End
1ea p/n 15665 AN-08 90-Deg. Male ORB Hose End
4ft AN-06 Stainless Steel Braided Fuel Line
15ft AN-08 Stainless Steel Braided Fuel Line
2ft ¼" OD Vacuum Tubing

The following steps are typical of most installations:

1. Once the engine has been allowed to cool, disconnect the negative battery cable, relieve fuel system pressure and drain engine coolant, referring to the appropriate vehicle service manual for the procedure on doing so.
2. First the factory manifold must be removed using the following steps, for specific details and instructions refer to the factory service manual.
3. Remove the turbo intercooler (top mount only) and air intake duct.
4. Disconnect all the wiring harness connections, noting where each goes.
5. Remove the bolts holding accessories and brackets to the manifold.
6. Disconnect all vacuum lines from the manifold, noting where each goes.
7. Remove the tumbler valve bolts connecting them to the heads, keeping the intake bolted to the top of the tumbler valve. In some cases it may be easier to remove the tumbler valves from the intake manifold.
8. Disconnect the fuel lines from the fuel rail assembly located on the driver side by the firewall, placing clean shop towels around the fuel lines to catch any gasoline that may be spilled during their removal

Failure to satisfy all safety considerations will result in fire, explosion, injury and/or loss of life to yourself and/or others.

9. Carefully lift off the intake manifold, tumbler valve, OE fuel rail assembly.
10. Remove the three bolts holding the OE fuel lines to the bottom of the intake manifold.
11. Remove the four bolts holding the OE fuel rails to the tumbler valves.
12. Remove the OE fuel rail assembly from the intake manifold assembly, being careful not to damage the fuel injector pipe insulator between the bottom of the OE fuel rail and the tumbler valve.

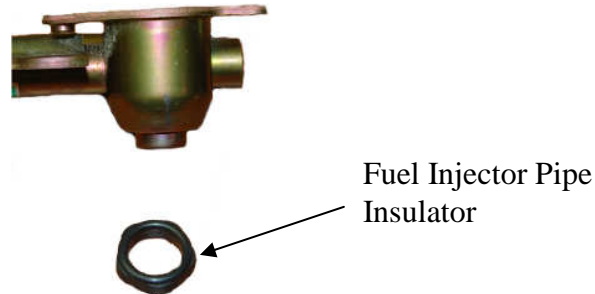

13. Remove each of the injector spring clips.
14. Place clean shop towels around the injectors to catch any gasoline that may be spilled during their removal. Remove each of the injectors from the manifold by gently pulling upward on each of the injectors.

Failure to satisfy all safety considerations will result in fire, explosion, injury and/or loss of life to yourself and/or others.



15. Remove the old o-rings from the fuel injectors, inspect the injectors for any dirt or debris and clean if needed. It is suggested that the old o-rings be replaced, contact your local auto parts store for replacement o-rings.
16. Coat the new fuel injector o-rings with a light oil to ease installation.

17. Carefully install the new injector o-rings on the injectors.
18. Confirm the backside (the end closest to the vehicles firewall) of both Aeromotive fuel rails have a p/n 15618 slim-line ORB-08 port plug pre-installed.

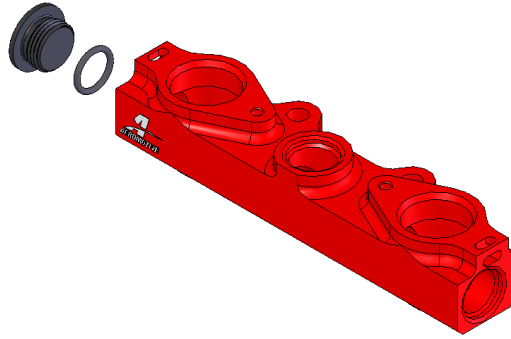

19. Place a thin coat of light oil in the fuel rail injector bores to help prevent cutting the o-rings during installation.
20. Carefully place each of the fuel injectors in the corresponding fuel injector bore of the Aeromotive fuel rails.

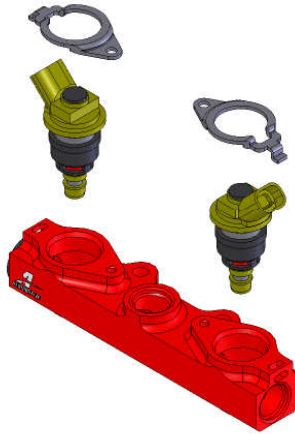

21. Reinstall the injector retaining clips and tighten screws.

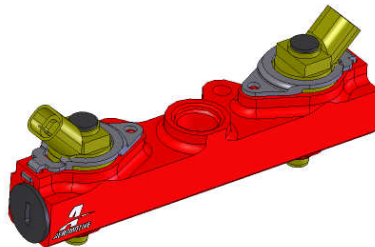

22. Inspect the fuel injector pipe insulators and replace if needed. Install each of the sealing washers on the bottoms of the fuel rail.

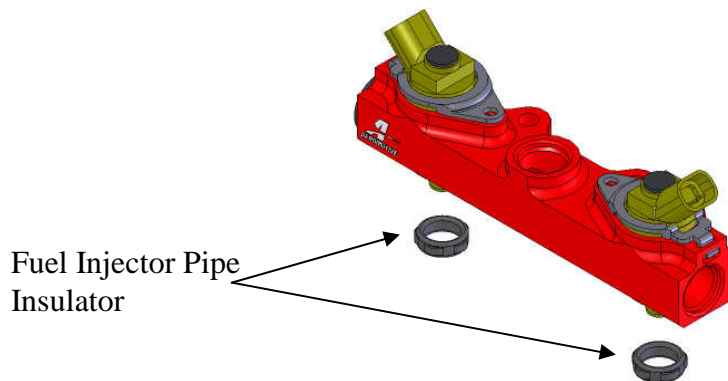

23. Place each of the Aeromotive fuel rail / injector assemblies onto each of the tumbler valves, being sure to align the bottom of the fuel rail with the injector bores in the tumbler valve.
24. Reinstall the fuel rail mounting bolts and tighten.
25. Position the intake manifold assembly on the engine.
26. Find suitable place in the vehicle's engine compartment to mount the Aeromotive regulator, typically on or near the passenger side strut tower. Using the supplied mounting bracket as a template, mark the bracket mounting holes and drill to accept a #10 screw.
27. With the bracket attached to the regulator, mount the bracket and regulator to the vehicle using two #10 screws, nuts and lock washers.
28. Install one ORB-10 o-ring on each of the two p/n 15610 ORB-10/AN- 08 port fittings and one ORB-06 o-ring on the p/n 15606 ORB-06/AN-06 port fitting. Install fittings into the regulator by threading the o-ring side of p/n 15610 into each of the two ORB-10 inlet ports on each side, and the o-ring side of p/n 15606 into the bottom/return port.

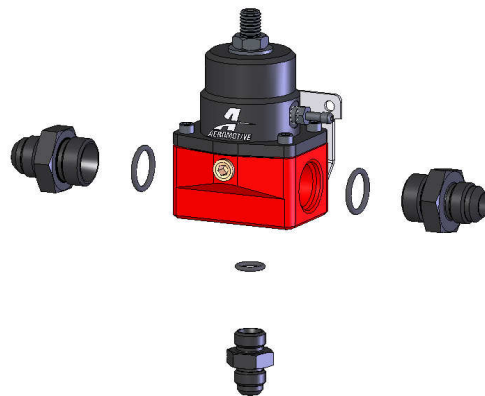

29. Install one ORB-08 o-ring on each of the two ORB-08/AN-08 port fittings.



30. Install one ORB-08 o-ring on the AN-08 90-degree male ORB hose end.



31. Thread the o-ring side of one of the ORB-08/AN-08 port fittings into the top center port, and thread the AN-08 90-degree male ORB hose end in the front port, of the passenger side fuel rail.

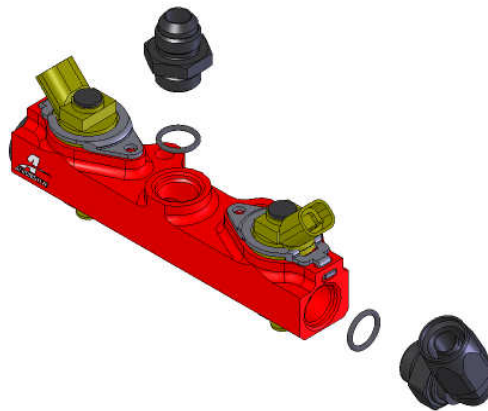

32. Thread the o-ring side of two of the ORB-08/AN-08 port fittings into the top center port, and in the front port, of the driver side fuel rail.

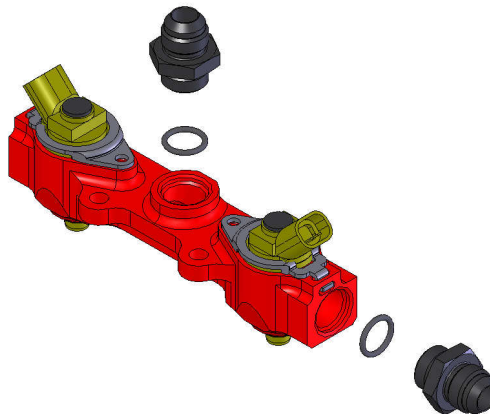

33. Connect the AN-08 45-degree hose end to one side of the fuel pressure regulator. Plan a route for the line between the fuel pressure regulator and the AN-08 90-degree male ORB Hose end located in the front of the passenger side fuel rail. Measure the length of fuel line needed and cut. See section titled Hose and Fitting Assembly for fuel line assembly instructions. Once the hoses are assembled, **ensure there is no debris in the hose** and install it.

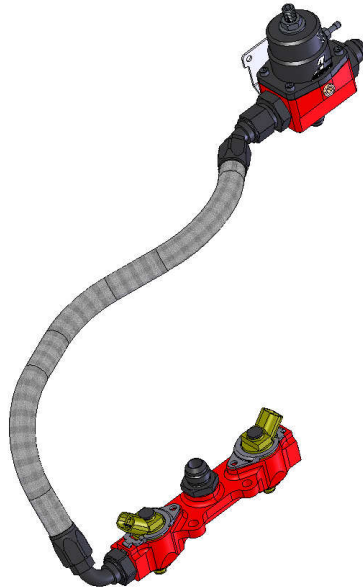

34. Reinstall intake manifold assembly replacing gaskets and retightening bolts as outlined in factory service manual.

Note: When reinstalling the tumbler valve / intake manifold assembly locate the sensor on the passenger side of the block directly behind the fuel rail and connect the wiring. With the bolts installed loosely in the tumbler valves make sure there is clearance between the plug in the back side of the fuel rail and the sensor by sliding the tumbler valve assembly forward then torque down the tumbler valves as outline in the vehicle service manual.

35. Connect one of the AN-08 90-degree hose ends to the fuel pressure regulator and another to the front side of the driver side fuel rail. Plan a route for the line between these two hose-ends, measure the length of line needed and cut. See section titled Hose and Fitting Assembly for fuel line assembly instructions. Once the hoses are assembled, **ensure there is no debris in the hose** and install it.

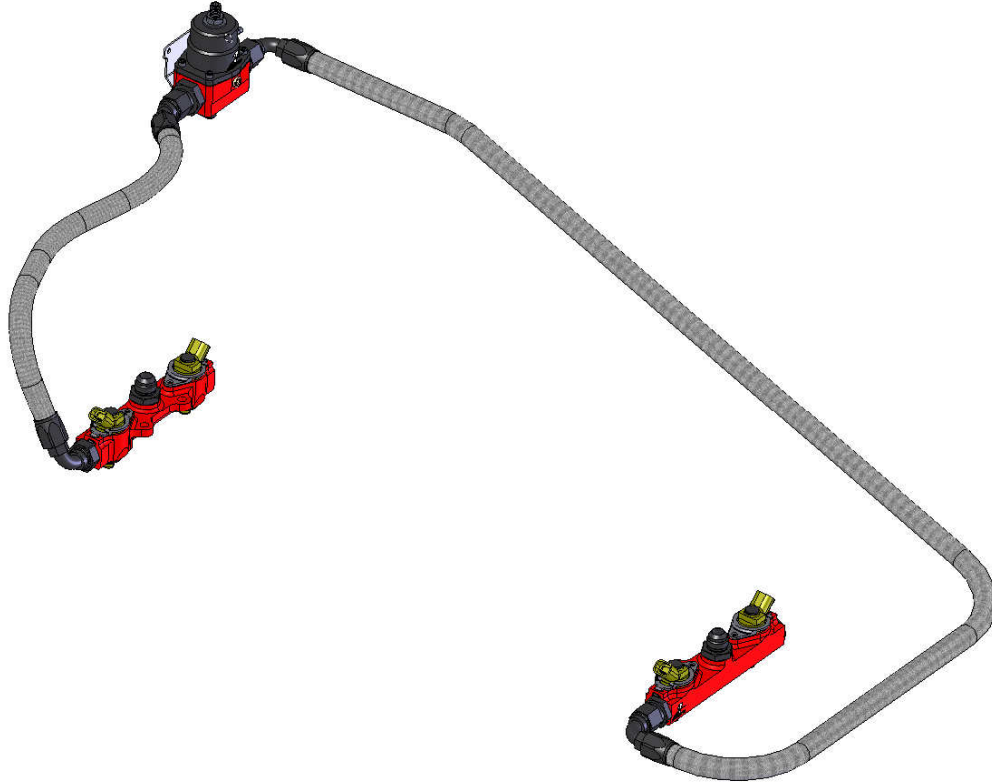

36. Install one ORB-06 o-ring over the male flare and up the shoulder of an AN-06 to 5/16 barb adapter fitting. Install the AN side of this fitting into the supply tee adapter fitting. Locate the assembled tee adapter fitting where it will connect to the OEM fuel supply hose.



37. Connect one of the AN-08 90-degree hose ends to the top center port on the driver side fuel rail and an AN-08 straight hose end to the supply line tee adapter fitting. Plan a route for the line between the fuel rail and the tee fitting, measure the length of fuel line needed and cut. See section titled Hose and Fitting Assembly for fuel line assembly instructions. Once the hoses are assembled, **ensure there is no debris in the hose** and install it.

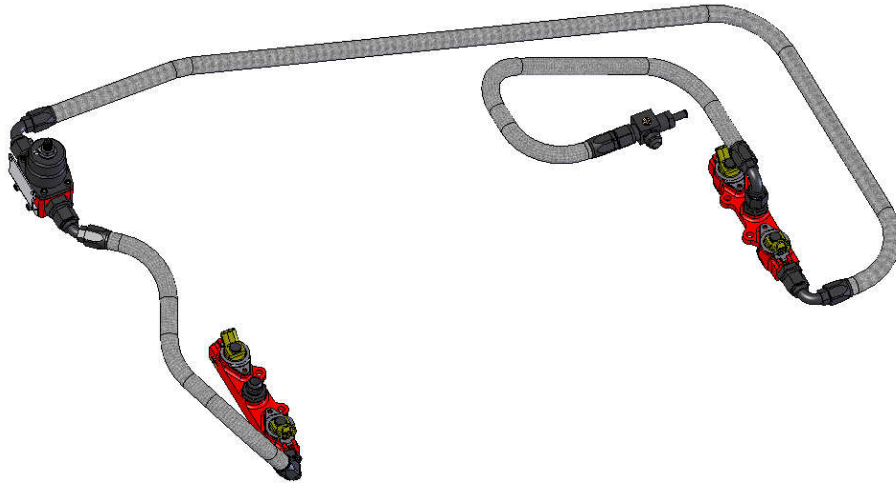

38. Connect one of the AN-08 90-degree hose ends to the top center port on the passenger side fuel rail and a second AN-08 90-degree hose end to the remaining AN-08 male on the supply line tee adapter fitting. Plan a route for the line between the fuel rail and the tee fitting, measure the length of fuel line needed and cut. See section titled Hose and Fitting Assembly for fuel line assembly instructions. Once the hoses are assembled, **ensure there is no debris in the hose** and install it.



39. Connect the AN-06 90-degree hose end to the bottom/return port located on the fuel pressure regulator and a AN-06 straight hose end to the AN-06 to 5/15 barb return line adapter fitting. Locate the AN-06 barb adapter fitting where it will connect to the OEM return line hose. Plan a route for the line between the fuel pressure regulator and the return line fitting, measure the length of fuel line needed and cut. See section titled Hose and Fitting Assembly for fuel line assembly instructions. Once the hoses are assembled, **ensure there is no debris in the hose** and install it.

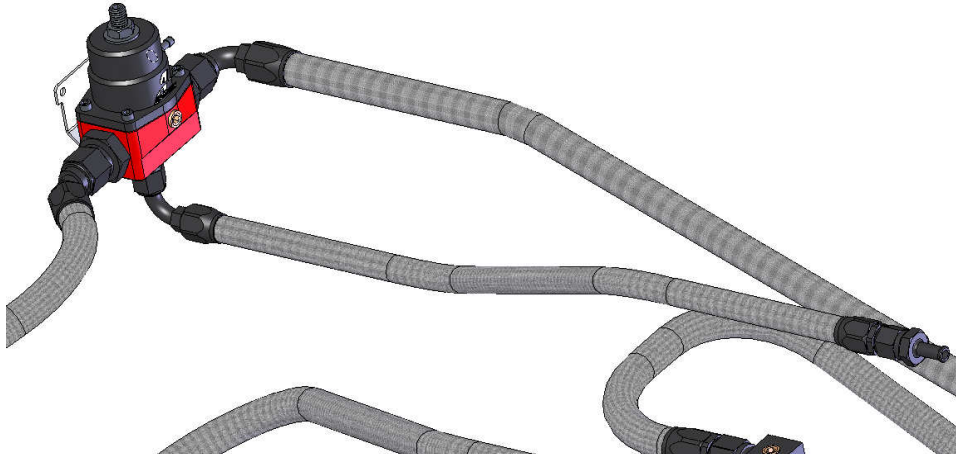

40. Install/tighten clamps securing the supply and return barb adapters to the OEM supply and return lines. Check all hose-end connections to ensure their properly tightened.
41. After installing and securing all the fuel lines, the system should look similar to below.

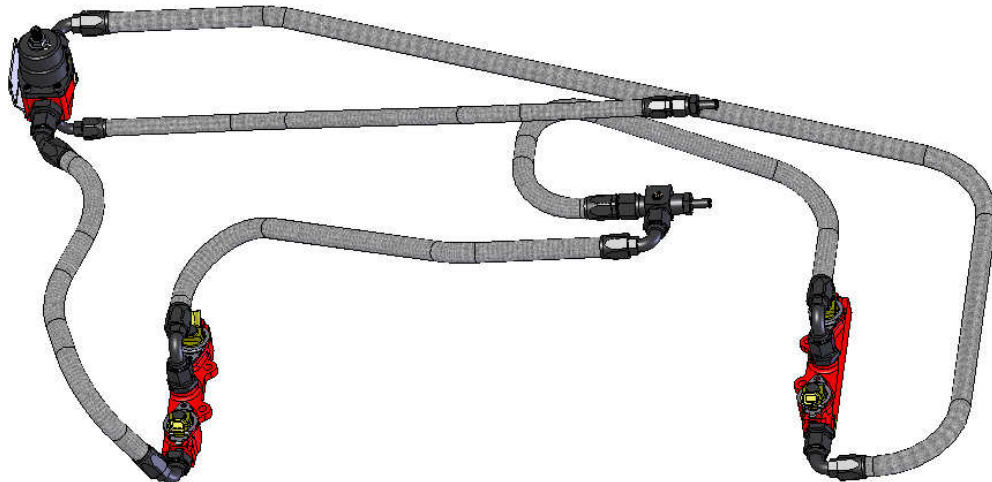

Ensure the any spilled gasoline and any gasoline soaked shop towels are cleaned up and removed from the vicinity of the vehicle!

42. Reinstall any electrical wiring, vacuum lines, fuel lines and throttle body components that were removed for the original fuel rail removal.
43. Refill engine coolant and check system for leaks.
44. Reconnect the battery and turn the ignition to the ON position WITHOUT starting the car. After several second turn the ignition key to the OFF position, wait one minute. Repeat this process until you pressurize the fuel system.
45. Adjust the fuel pressure regulator to the desired fuel pressure. Once the fuel pressure gauge registers the desired fuel system pressure and there are no fuel leaks, start the engine.
46. With fuel pressure in the system, check for leaks from and around all the fuel system components and all fuel lines and connections. If any fuel leaks are found, turn the ignition key to the OFF position, remove any spilled gasoline and repair the leak before proceeding.
47. Once the fuel system has been confirmed to be leak free, test drive the vehicle to insure proper operation and re-check the fuel and coolant systems for leaks. If any leaks are found, immediately shutoff the engine and repair the leak(s).

Hose and Fitting Assembly

CAUTION:

When assembling this product, wear eye goggles and other safety apparel as needed to protect yourself from debris and sharp edges.

- A. Wrap hose with masking tape at desired cutoff length. Cut hose through masking tape squarely to desired length using a cut-off machine or a fine tooth hacksaw. Remove the masking tape.
- B. Unthread the hose socket from the rest of the hose end fitting.



- C. Insert hose in the socket with a twisting and pushing motion until the hose is fully seated in the socket.
- D. Using a grease pencil, marker or tape, mark the location of the hose in relation to the hose socket which you just installed.
- E. Using a light oil lubricate the inside of the hose and the hose end mating parts.
- F. Carefully thread the hose end onto the hose socket, making sure that the hose does not push out of socket, by observing the mark you placed on the hose in step D.

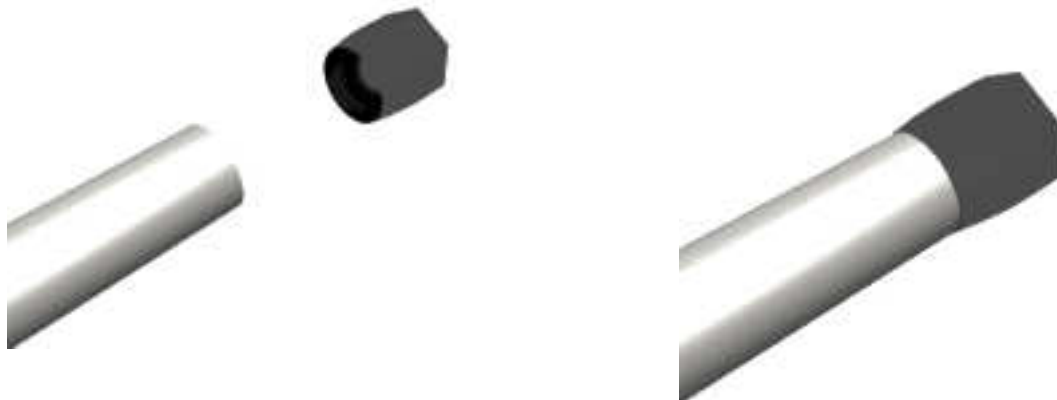



- G. Using a properly sized wrench, complete threading the two components together (The maximum allowable gap between the two fitting components is .030 inches).



- H. Inspect the hose for push out by comparing the mark you made on the hose in step D to the hose end socket location.
- I. Clean all debris from exterior and interior of hose.
- J. All lines should be tested to twice their operation pressure prior to use.

AEROMOTIVE, INC. LIMITED WARRANTY

This Aeromotive Product, with proof of purchase dated on or after January 1, 2003, is warranted to be free from defects in materials and workmanship for a period of one year from the original date of purchase. No warranty claim will be valid without authentic, dated proof of purchase.

This warranty is to the original retail purchaser and none other and is available directly from Aeromotive and not through any point of distribution or purchase.

If a defect is suspected, the retail purchaser must contact Aeromotive directly to discuss the problem, possible solutions and obtain a Return Goods Authorization (RGA), if deemed necessary by the company. Please call 913-647-7300 and dial option 3 for the technical service dept. All returns must be shipped freight pre-paid to the company and with valid RGA before they will be processed.

Aeromotive will examine any product returned with the proper authorization to determine if the failure resulted from a defect or from abuse, improper installation, misapplication or alteration. Aeromotive will then, at it's sole discretion, return, repair or replace the product.

If any Aeromotive product is determined defective, buyer's exclusive remedy is limited in value to the sale price of the good. In no event shall Aeromotive be liable for incidental or consequential damages.

Aeromotive expressly retains the right to make changes and improvements in any product it manufactures and sells at any time. These changes and improvements may be made without notice at any time and without any obligation to change the catalogs or printed materials.

Aeromotive expressly retains the right to discontinue at any time and without notice any Aeromotive product that it manufactures or sells.

This warranty is limited and expressly limits any implied warranty to one year from the date of the original retail purchase on all Aeromotive products.

No person, party or corporate entity other than Aeromotive shall have the right to: determine whether or not this Limited Warranty is applicable to any Aeromotive product, authorize any action whatsoever under the terms and conditions of this Limited Warranty, assume any obligation or liability of any nature whatsoever on behalf of Aeromotive under the terms and conditions of this Limited Warranty.

This Limited Warranty covers only the product itself and not the cost of installation or removal.

This Limited Warranty is in lieu of and expressly excludes any and all other warranties, expressed or implied. This Limited Warranty gives you specific legal rights, and you may also have other rights which vary from state to state.