



Installation Instructions

For Part Numbers:

200-185	700-469 Airaid Oiled Media Filter
201-185	701-469 SynthaMax Dry Media Filter - Red
202-185	702-469 SynthaMax Dry Media Filter - Black
203-185	703-469 SynthaMax Dry Media Filter - Blue

2005-06 Cadillac Escalade/ESV/EXT
 2005-06 Chevrolet Avalanche 1500
 2005 Chevrolet Silverado 1500
 2005-06 Chevrolet Tahoe/Suburban 1500/2500
 2006 Chevrolet Tahoe (Canadian)
 2005-06 GMC Sierra 1500/1500HD/2500HD/3500HD
 2007 GMC Sierra "Classic" 1500/1500HD/2500HD/3500HD
 2005-06 GMC Yukon/Yukon XL 1500/2500
 4.8L V8, 5.3L V8, 6.0L V8
 With Electric Cooling Fan & Low Profile Hood

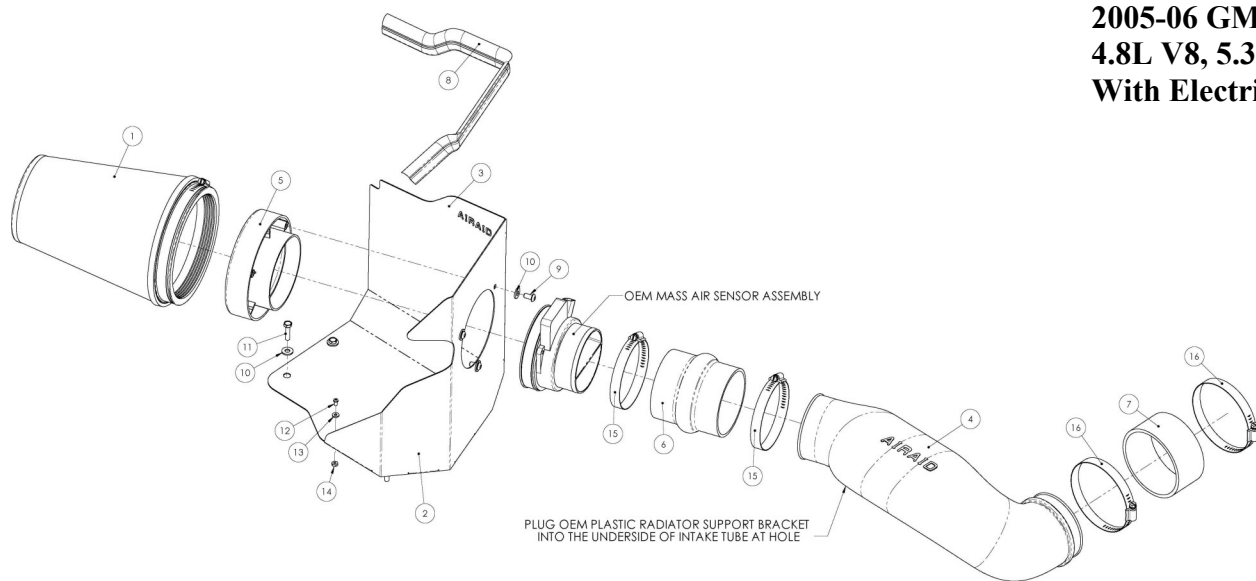

Component Identification

1.	Airaid Premium Filter	1
2.	MAF Panel Coated	1
3.	Rear Air Dam Coated	1
4.	Modular Intake Tube	1
5.	Black Filter Adapter	1
6.	Urethane Hump Hose	1
7.	Urethane Coupler	1
8.	Weather Strip 19 1/2"	1
9.	1/4"-20x1/2" SS Button Head	3
10.	1/4" Flat Washer	7
11.	M6-1x25 Hex Bolt	4
12.	6-32 x 5/16" Screw	5
13.	#6 Flat Washer	5
14.	6-32 Keps Nut	5
15.	#60 Hose Clamp	2
16.	#64 Hose Clamp	2

Full color instructions can be viewed on our web site at Airaid.com. Use the **Product Search** function to find your part number, and click **View Details**.



1. **Disconnect negative battery cable.**
 With a 5/16" socket, remove one bolt on the top of the beauty cover. Set the bolt and the cover aside for re-installation later.

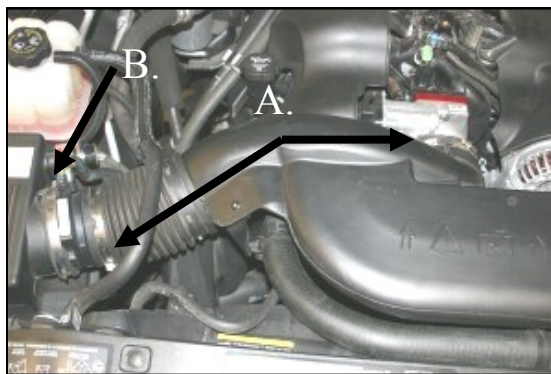

2. A.) Loosen the hose clamps on both ends of the factory intake tube. B.) Next loosen the hose clamp on the Mass Air Flow sensor where it clamps on the factory airbox.



3. With a screwdriver, pry the factory tube away from the plastic clamp on the radiator hose, and remove the tube.



4. Without disconnecting the electrical connector, remove the Mass Air Flow sensor from the factory airbox, and set it aside.



5. Grab the factory airbox and rock it back and forth, and remove it from the vehicle. It is only held in by grommets, no bolts.

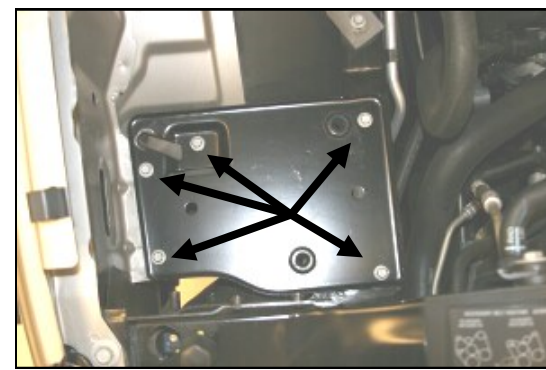

6. Remove 5 bolts and remove the factory airbox mounting plate.



7. Assemble the two Cool Air Dam panels (#2) and (#3) using the five supplied screws (#12), washers (#13), and nuts (#14), as shown.



8. Install the filter adapter (#5) into the CAD using three button head bolts (#9), and washers (#10).



9. Install the assembled CAD in place of the factory airbox using four bolts (#11) and washers (#10). Do not over tighten the bolts.



10. Re-install the Mass Air Flow sensor onto the filter adapter, and tighten the hose clamp. Make sure the rectangle area where the wiring connects is pointing straight up.



11. Install the urethane hump hose (#6) on the Mass Air Flow sensor with two #60 hose clamps (#15). Next install the coupler (#7) on the throttle body with two #64 hose clamps (#16).



12. Install the Modular Intake Tube into the hump hose first, and then into the throttle body. Adjust for fit, and tighten all four hose clamps. Re-insert the plastic piece from step #3 into the hole on the bottom of the MIT.



13. Install the Airaid Premium Filter (#1) onto the filter adapter (#5), and tighten the hose clamp. Next install the weather strip (#8) onto the top of the CAD as shown. For ease of installation start at the fender, and work towards the radiator.



14. Re-install the beauty cover and bolt removed in step #1.

15. Double check your work!

Make sure there is no foreign material in the intake path. Make sure all clamps, hoses, bolts, and screws are tight.

16. Reconnect the negative battery cable!

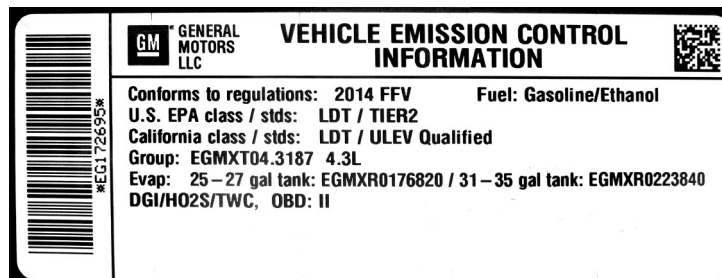

WARNING! If your vehicle has a Vehicle Emission Control Information decal affixed to the factory air-box, a new replacement label must be obtained and installed in a readily visible position in the engine compartment in order to remain CARB compliant. Failure to do so will prevent the vehicle from passing a smog check. Replacement labels can be ordered from your local dealership. Regulations state that the VEI label shall not be affixed to any equipment which is easily detached from the vehicle. Label placement, under the hood on a painted surface is recommended.

Thank you for purchasing the Airaid Intake System. Contact Airaid @ (800) 498-6951 8:00 AM - 5:00 PM MST weekdays for questions regarding fit or instructions that are not clear to you. Your Airaid Intake System was carefully inspected and packaged. Check that no parts are missing, or were damaged during shipping. If any parts are missing, contact Airaid. The air filter element is protected from direct exposure to water and debris; care should be taken not to drive through deep water. WATER INGESTION IS THE DRIVERS RESPONSIBILITY! The air filter is reusable and should be cleaned periodically.

FILTER IDENTIFICATION

700-469 Airaid Oiled Media
702-469 Airaid SynthaMax Dry Media - Black

701-469 Airaid SynthaMax Dry Media - Red
703-469 Airaid SynthaMax Dry Media - Blue

For your Oiled media filter we suggest using the AIRAID Filter Tune-Up Kit!

SynthaMax

Do Not Oil



P/N 790-551 Aerosol Spray
P/N 790-550 Squeeze Spray



Synthamax Air Filters do not require oil. Service air filter as needed by cleaning with common non-petroleum all-purpose household cleaner and water. Simple Green®, Formula 409® or equivalent works great. Apply cleaner to outside of air filter and allow to soak. Then flush filter clean from the inside out with a garden hose and repeat steps if necessary. Do not apply high pressure water or air to clean filter. Allow filter to air dry and reinstall.