

AIRRAID®

INTAKE SYSTEMS

#300-128 INSTALLATION INSTRUCTIONS

03-04 Dodge Cummins 5.9L Turbo Diesel Quick Fit

(Note : Use P/N 300-155 For 2004-07 vehicles w/optional “quiet hood pad”)

Thank you for purchasing the Airaid Intake System. Please read the instruction manual carefully before proceeding with the installation. Contact Airaid @ (800) 498-6951 8:00 AM - 5:00 PM MST weekdays for questions regarding fit or instructions that are not clear to you. Your Airaid Intake System was carefully inspected and packaged. Check that no parts are missing, or were damaged during shipping. If any parts are missing, contact Airaid. The air filter element is protected from direct exposure to water and debris; care should be taken not to drive through deep water. WATER INGESTION IS THE DRIVERS RESPONSIBILITY! The air filter is reusable and should be cleaned using the Airaid Filter Tune-Up Kit periodically.

Thank you for selecting Airaid.



Packing List:

720-128	Airaid Premium Filter	1
KIT128FPC	Front Air Dam Panel	1
KIT128RPC	Rear MAF Air Dam Panel	1
KIT128A	Black Plastic Filter Adapter	1
KITWSTRIP02	Weather Strip 27"	1
KIT155HP	Hardware & Instructions	1
- KIT15FW3016	#8 Flat Washer	2
- KIT25C62HCSS	1/4-20 x 5/8" Hex Bolt	3

Packing List (cont'd):

- KIT09FWZ019	1/4" Flat Washer	3
- KIT6C31MXPPZ	6-32 Phillips Screw	4
- KIT6CNKEPZ	6-32 Nut	4
- KIT6NWSAPZ	#6 Washer	4
- KIT10BHCP63	8-32 Button Head Screw	2

Tools Required for this Installation:

Flat Head Screwdriver
7mm & 8mm Sockets & Ratchets
3/32" Allen Wrench, T-20 bit

Installation Instructions. Read Me!



1. Disconnect the negative battery cable and disconnect the electrical connector. Using the T-20 bit, loosen the two star head bolts and remove the electrical sensor. (Retain sensor for installation of Airaid Intake System)



2. Remove the factory filter minder with grommet and retain for use with the Airaid Intake System.



Filter Minder



Sensor



Factory Grommet

3. Parts to retain for installation of Airaid Intake System.



4. Loosen the clamp connecting the factory air box lid to the factory air intake tube and unclip the factory air box lid and remove entire filter/intake assembly from vehicle. (Note: leave the lower factory air box lid in place)

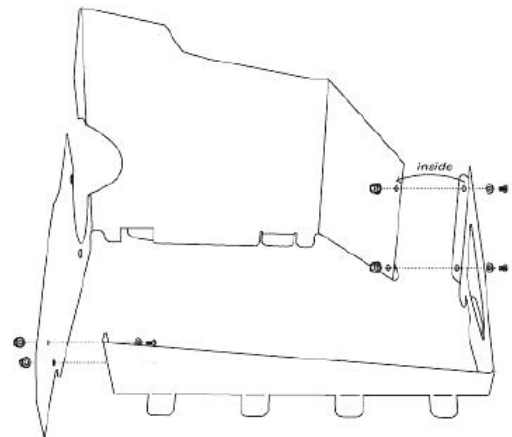

5. Assemble Airaid Quick Fit cold air dam panels using the (4) 6/32 bolts, washers and nuts provided.

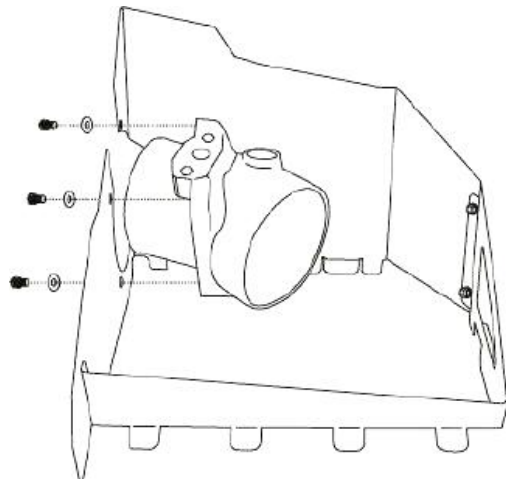

6. Assemble the air filter adapter to the cold air dam using the (3) 1/4-20 bolts and washers provided.

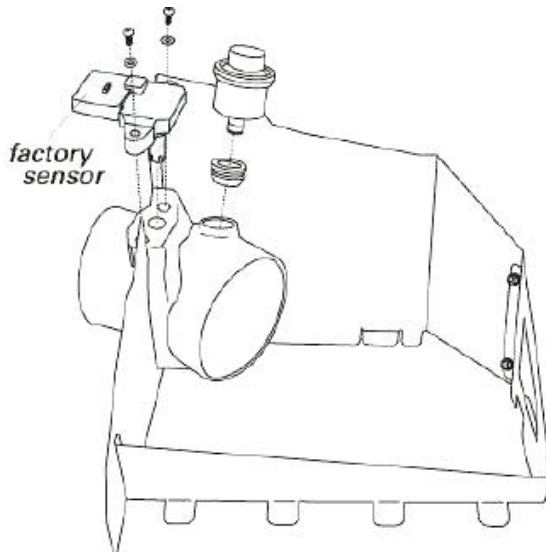

7. Fasten the factory sensor on top of the Airaid adapter using the (2) 8/32 screws and washers & a 3/32 Allen Wrench to tighten. In addition, mount the factory rubber grommet and filter minder onto the Airaid plastic adapter.

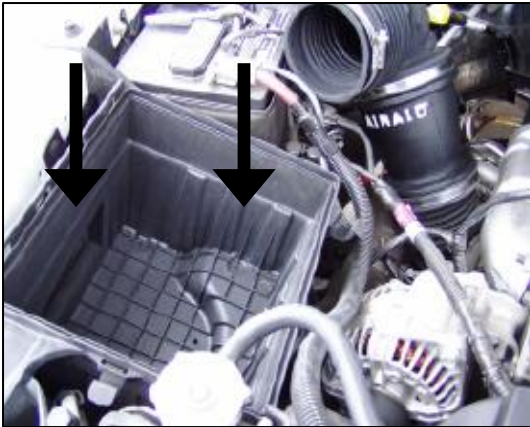

8. Install Airaid intake assembly in place of the factory air box lid & tighten factory hose clamp on intake tube to Airaid system.

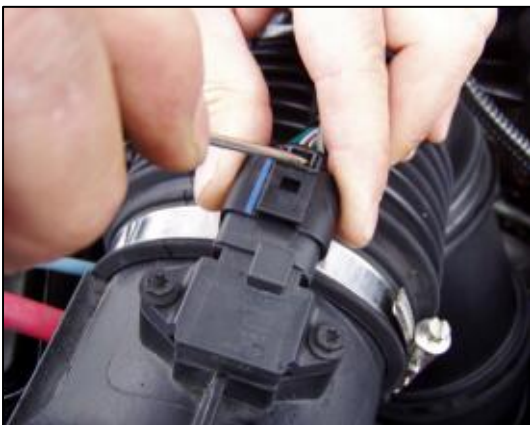

9. Re-connect the wire harness to the sensor on top of the adapter.

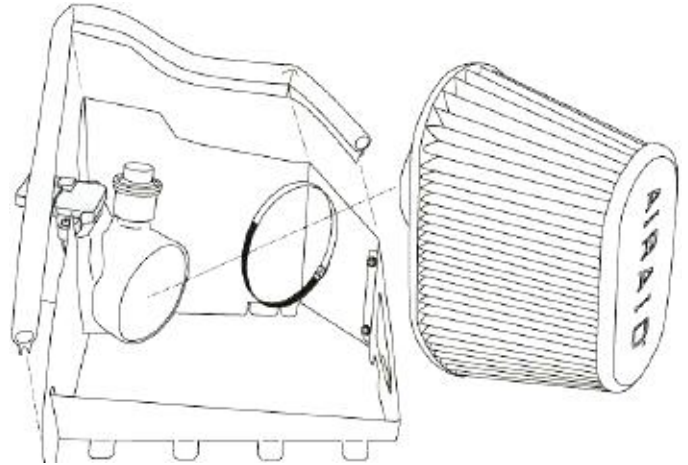

10. Mount Airaid Premium Filter to the filter adapter and tighten hose clamp. Next, press the weather strip onto the top of the Cool Air Dam (*Hint: start at a corner and work toward the edges*).

11. Double check your work to be certain that all nuts, bolts, and clamps are securely fastened.

12. Reconnect the negative battery cable.



Airaid Modular Intake Tube P/N 300-928 is also available for this application to replace the factory silencer tube. Please contact your local dealer for details.



Before



After!



Don't Forget Your AIRAID Filter Tune-Up Kit!



P/N 790-550

Instructions Revision
Date: 02/01/07