



Installation Instructions

For Part Numbers:

- 450-174 700-461 Airaid Oiled Media Filter
- 451-174 701-461 SynthaMax Dry Media Filter - Red
- 452-174 702-461 SynthaMax Dry Media Filter - Black
- 453-174 703-461 SynthaMax Dry Media Filter - Blue

2012-13 Boss 302 Mustang
5.0L V8

Component Identification

1.	Airaid Premium Filter	1
2.	Airaid Intake Tube	1
3.	Modular Venturi Tube (MVT)	1
4.	Cool Air Box	1
5.	Urethane Hump Hose	1
6.	Silicone Reducer	1
7.	Filter Adapter	1
8.	Weather strip 25"	1
9.	1/4-20 Button Head Bolt	3
10.	1/4" Flat Washer	3
11.	8-32x3/8" Button Head Screw	2
12.	#72 Hose Clamp	2
13.	#64 Hose Clamp	1
14.	#56 Hose Clamp	1
15.	Firewall Plug*	1
16.	5/8 Aluminum Fitting	1
17.	5/8 Grommet	1
18.	174 O Ring	1
19.	#20 Torx Bit	1

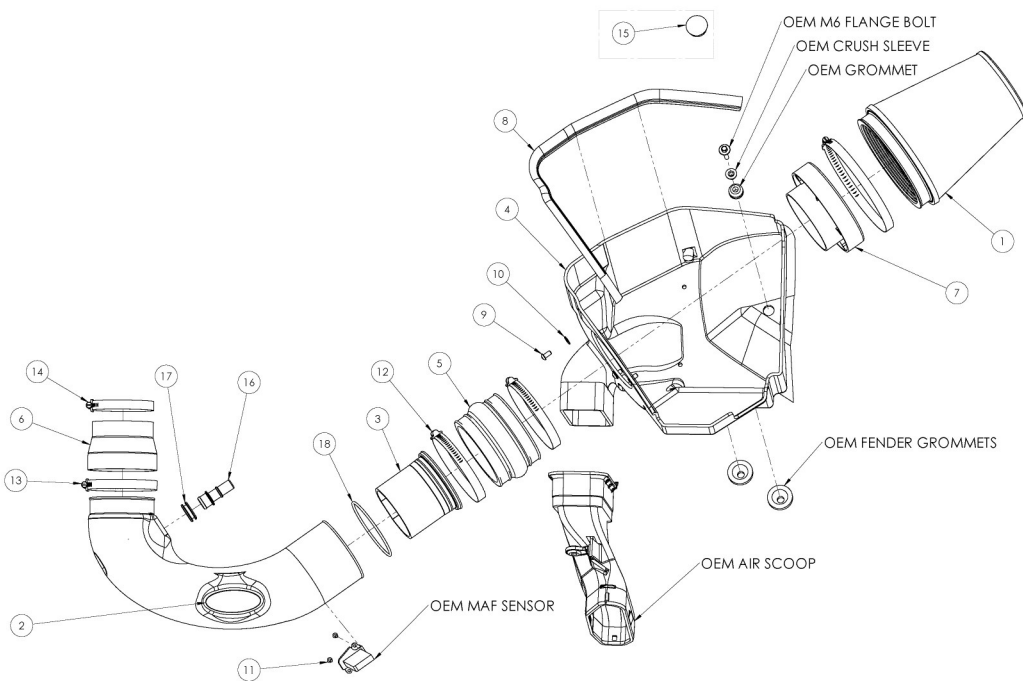

INSTALL NOTE: If you are installing this kit on a vehicle equipped with a Power Dome Hood with Heat Extractors we suggest the use of our optional AIRAID pre-filter (Part #799-469) to give an added layer of protection from the elements

Full color instructions can be viewed on our web site at Airaid.com. Use the **Product Search** function to find your part number, and click **View Details**.



Disconnect The Negative Battery Terminal!

1. Make sure the ignition switch is turned off and the parking brake has been set.

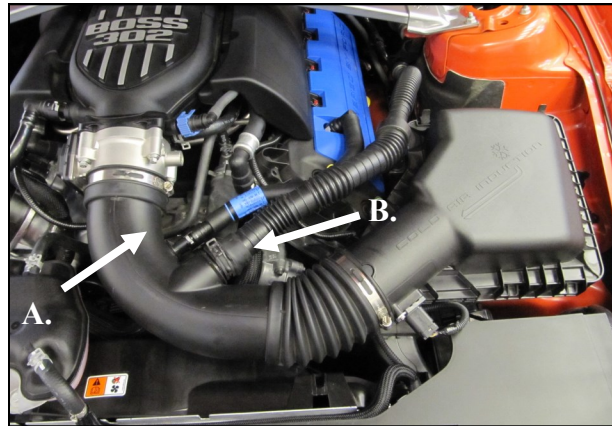

2. A) Loosen the hose clamps on the factory intake tube B) Squeeze the clamp and disconnect the resonator from the air intake tube. C) Carefully depress the hose lock tab and disconnect the crank case breather line. D) Remove the factory intake tube.

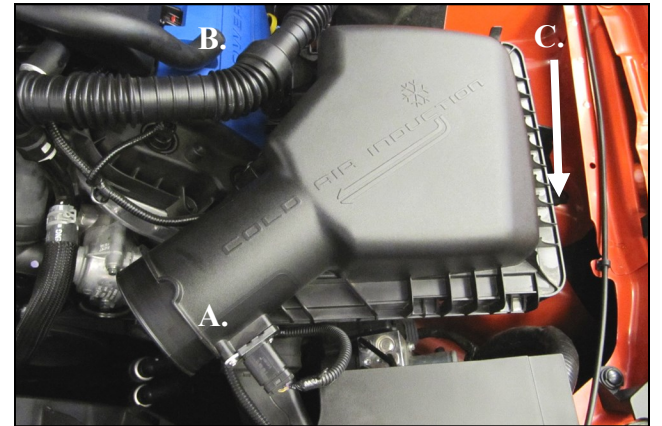

3. A) Slide the red tab out of the connector and disconnect the Mass Air Flow sensor. Carefully pry the harness anchor from the air box using a standard screwdriver. B) Separate the resonator tube from the stand off attached to the Air box lid. C) Using a 10mm socket, remove the bolt securing the air box to the inner fender and remove the air box assembly. This bolt will be reused in step 12.



4. Unbolt the Intake resonator from the inner fender and disconnect it at the drivers side firewall. Remove the entire assembly from the vehicle and set it aside. It will not be reused.



5. Plug the resonator hole in the firewall with the Firewall Plug (#15).

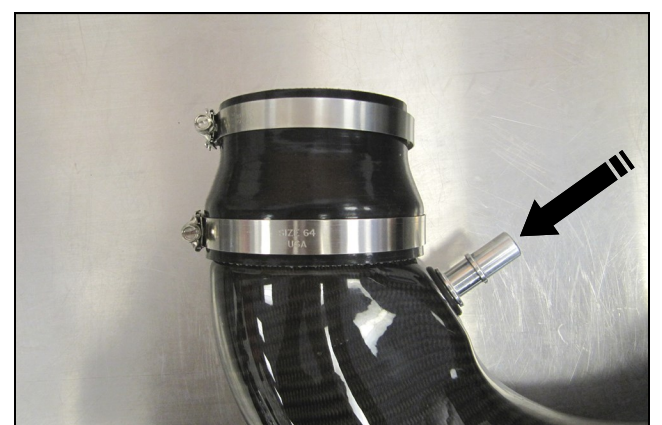

6. A.) Install the Silicone Reducer (#6) and Hose clamps onto the Airaid Intake Tube (#2). Place the #56 clamp (#14) on the Throttle body side of the reducer, and the #64 clamp (#13) on to the tube side. B.) Insert the 5/8" Grommet (#17) into the Intake tube as shown. Complete the tube assembly by inserting the 5/8 Aluminum Fitting (#16) into the Grommet.

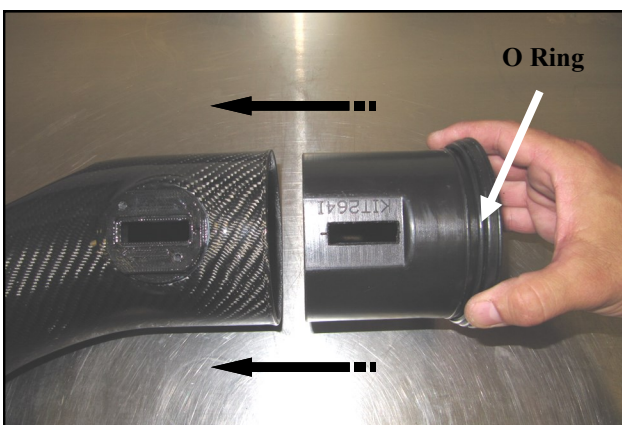

7. Slide the Modular Venturi Tube (#3) into the Airaid Intake tube (#2). Make sure to align the two slots for the Mass Air Flow sensor and that the O Ring (#18) is in Place.



8. Install the Mass Air Flow sensor into the intake tube using two provided 8-32x3/8" screws (#11).



9. Install the Filter Adapter (#7) onto the Airaid Cool Air Box (#4) as shown. Use the three 1/4-20 button head bolts (#9), and flat washers (#10) to secure the Adapter.

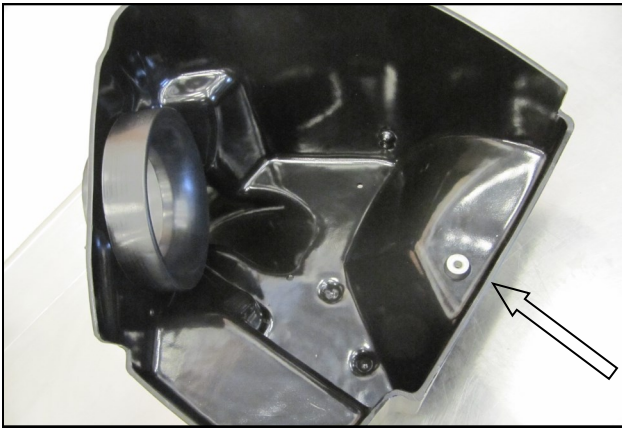

10. Remove the factory upper air box mounting grommet and steel sleeve, and re-install into the Airaid CAB.



11. Install the hump hose (#5) and two #72 hose clamps (#12) onto the filter adapter as shown. Leave the two hose clamps loose for now.

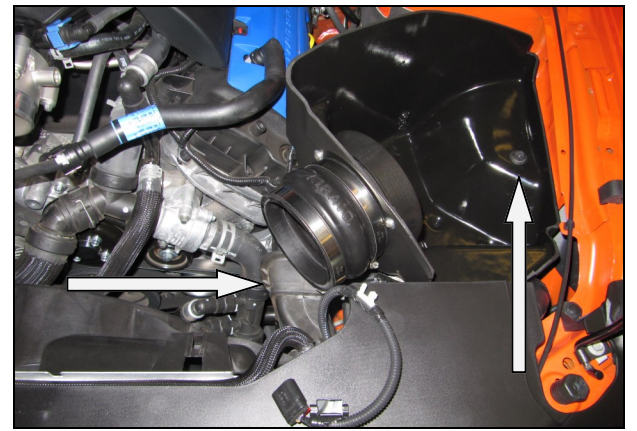

12. Install the CAB into the vehicle. Make sure that the air inlet of the CAB aligns with the factory duct, and the two locating pins on the bottom are seated in the factory grommets. Next reinstall the factory bolt that was removed in step #3 thru the steel sleeve and grommet and into the inner fender.



13. Install the Airaid Intake tube onto the throttlebody first then into the Hump Hose and tighten the clamps. Reconnect the crank case breather line to the Aluminum fitting on the Intake Tube.

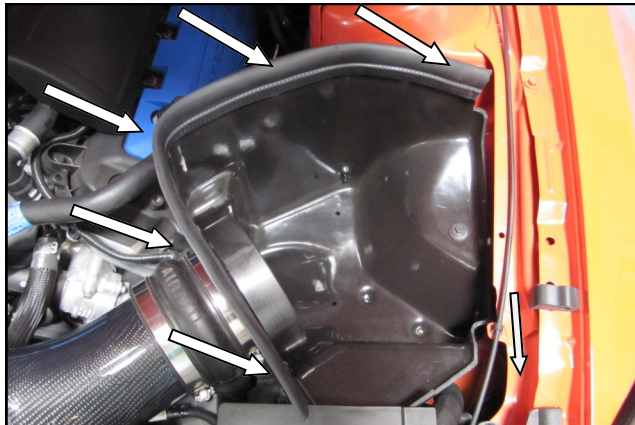

14. Install the Weather Strip (#8) onto the Cool Air Box with the contoured edge rolling away from the filter area. Start at the front of the vehicle and work your way back



15. Install the Airaid Premium Filter (#1) onto the filter adapter and tighten the hose clamp.



16. Reconnect the Mass Air Flow sensor, which is now located in the lower back side of the intake. Slide the locking tab back into the connector.

17. Double check your work!

Make sure there is no foreign material in the intake path. Make sure all clamps, hoses, bolts, and screws are tight. Double check the hood clearance!

Reconnect the negative battery cable!

Thank you for purchasing the Airaid Intake System. Contact Airaid @ (800) 498-6951 8:00 AM - 5:00 PM MST weekdays for questions regarding fit or instructions that are not clear to you. Your Airaid Intake System was carefully inspected and packaged. Check that no parts are missing, or were damaged during shipping. If any parts are missing, contact Airaid. The air filter element is protected from direct exposure to water and debris; care should be taken not to drive through deep water. WATER INGESTION IS THE DRIVERS RESPONSIBILITY! The air filter is reusable and should be cleaned periodically.

FILTER IDENTIFICATION

700-461 Airaid Oiled Media
702-461 Airaid SynthaMax Dry Media - Black

701-461 Airaid SynthaMax Dry Media - Red
703-461 Airaid SynthaMax Dry Media - Blue

**For your Oiled media filter
we suggest using the AIRAID
Filter Tune-Up Kit!**



P/N 790-551 Aerosol Spray
P/N 790-550 Squeeze Spray



SynthaMax

Do Not Oil

Synthamax Air Filters do not require oil. Service air filter as needed by cleaning with common non-petroleum all-purpose household cleaner and water. Simple Green®, Formula 409® or equivalent works great. Apply cleaner to outside of air filter and allow to soak. Then flush filter clean from the inside out with a garden hose and repeat steps if necessary. Do not apply high pressure water or air to clean filter. Allow filter to air dry and reinstall.