



350 S. St. Charles St. Jasper, In. 47546
Ph. 812.482.2932 Fax 812.634.6632

www.ridetech.com

Part # 11260210
68-74 GM "X" Body Complete CoilOver System

Front Components:

1	11263510	Front HQ Series CoilOvers
1	11162899	Front Lower StrongArms
1	11163699	Front Upper StrongArms
1	11009300	RideTech Tall Spindles
1	11169100	Front MuscleBar

Rear Components:

1	11267199	Rear AirBar – Bolt-on 4 Link
1	11266510	Rear HQ Series CoilOvers

Components:

1	85000000	Spanner Wrench
---	----------	----------------



350 S. St. Charles St. Jasper, In. 47546
Ph. 812.482.2932 Fax 812.634.6632
www.ridetech.com

Part # 11263510
68-74 GM "X" Body HQ Series Front CoilOvers
For Use w/ StrongArms and Tall Spindle

Shock Assembly:

2	24139999	3.6" stroke HQ Series shock
2	90009989	2.75" threaded stud top
2	90001994	.625" I.D. bearing
4	90001995	bearing snap ring

Components:

2	59080650	Coil spring – 8" long / 650 # rate
2	90002313	2.75" stud top base
2	90002222	Spring retainer kit (included upper and lower spring retainer, screw & clip)
2	90001902	Aluminum cap for Delrin ball
2	90001903	Delrin ball upper half
2	90001904	Delrin ball lower half
4	70010828	Delrin Spring Washer

Hardware:

2	99562003	9/16" SAE Nylok jam nut	Stud top hardware
---	----------	-------------------------	-------------------

COILOver

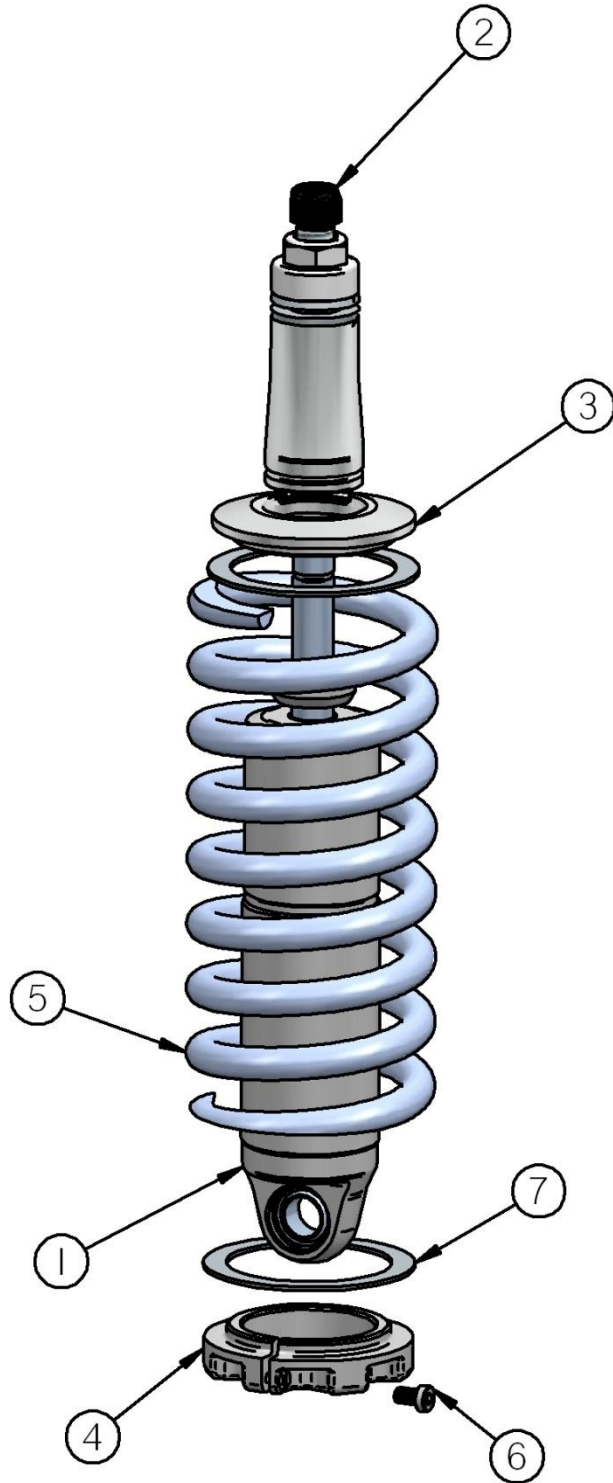

1. Impact Forged, Monotube shock
2. Rebound adjustment knob (SA Only)
3. Upper coil spring retainer
4. Lower coil spring retainer
5. High tensile coil spring
6. Set screw
7. Delrin Spring Washer

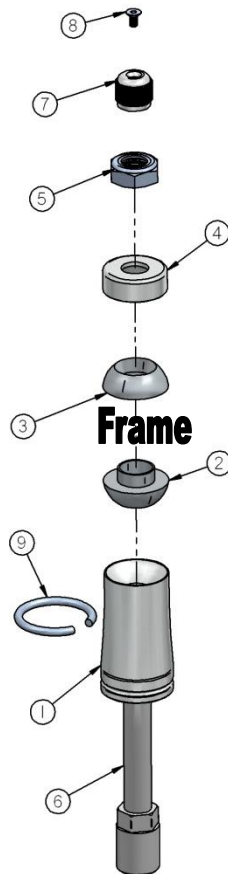

1. Stud top base
2. Lower Delrin ball half
3. Upper Delrin ball half
4. Aluminum cap
5. 9/16" Nylok jam nut
6. Threaded stud
7. Adjustment knob (SA Only)
8. Screw
9. Snap ring

COILOver

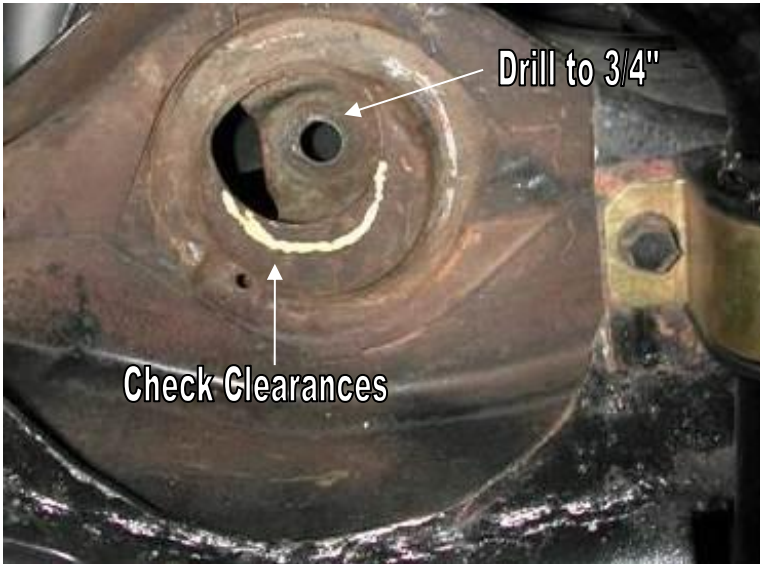

1. Inspect the factory welds attaching the upper shock bracket to the frame. Re-weld if necessary.

2. To allow the step in the lower Delrin ball half to slide into the factory shock hole, the hole will need to be drilled out to $\frac{3}{4}$ ".

3. Assemble the CoilOver then place into the coil spring pocket w/ the stud and lower Delrin ball sticking through the factory shock hole.



4. Check clearance between the upper spring retainer and stud base with the factory coil spring retainer.

5. Place the upper Delrin ball over stud, then the aluminum cap. Secure the assembly w/ the 9/16" Nylok jam nut.

6. Attach the bottom of the shock to the lower StrongArms using the spacers and hardware supplied w/ the arm.



350 S. St. Charles St. Jasper, In. 47546
Ph. 812.482.2932 Fax 812.634.6632

www.ridetech.com

Part # 11162899

67-69 GM "F" Body & 68-74 GM "X" Body Lower StrongArms

For Use w/ Shockwave or CoilOver

Components:

1	90000621	Driver side lower arm
1	90000622	Passenger side lower arm
2	90000898	Ball joint (includes boot, grease fitting, castle nut & cotter pin)
4	90000516	Inner bushing sleeve - .5" I.D. x .75" O.D. x 2.375" long
8	70010759	Delrin bushing half – 1.5" O.D.
4	90002062	Aluminum spacers – shock to lower arm

Hardware:

2	99501024	1/2"-13 x 3 1/4" Gr.5 bolt	Shockwave to lower arm
4	99501005	1/2"-13 x 3 1/2" Gr.5 bolt	Lower arm to frame
6	99502001	1/2"-13 Nylok Nut	Lower arm
2	99371010	3/8" x 5 1/2" USS bolt	Sway bar end link
4	99372002	3/8" USS Nylok Nut	Sway bar end link & Steering Stop
2	99371005	3/8" x 1 1/4" USS bolt	Steering stop

STRONG ARMS™

by Air Ride Technologies

Installation Instructions



1. After removing the factory lower control arm, clean the bushing mounting surfaces on the frame.
2. Fasten the lower arm to the frame with the $\frac{1}{2}$ " x $3 \frac{1}{2}$ " bolts and Nylok nuts supplied.

Note: On some cars the frame brackets may be pinched and will need to be spread back apart to allow bushing to slide in.

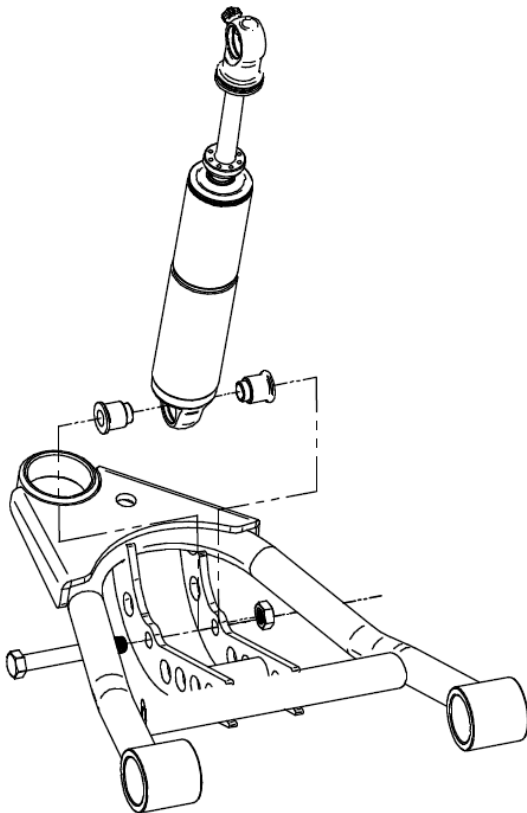

3. Swing the lower StrongArm up to the Shockwave and secure with the $\frac{1}{2}$ " x $3 \frac{1}{4}$ " bolt and Nylok nut, an aluminum spacer must be installed on each side of the bearing.
4. Slide the ball joint boot over the stud, then push the stud up through the spindle. Secure w/ the new castle nut and cotter pin supplied.
5. Grease the ball joints.
6. The Delrin Bushings are self-lubricating, no grease is required.



7. Screw a $3/8"$ x $1\ 1/4"$ bolt and nut into the hole in the side of the lower arm. This will act as an adjustable steering stop. After the wheel is install check wheel clearance all full lock and adjust as necessary.

8. If using factory style sway bar, shorten the sway bar end link spacer to $1\ 1/2"$ tall. New $3/8"$ x $5\ 1/2"$ bolts and Nylok nuts are supplied.

STRONG ARMS™

by Air Ride Technologies

Item #	Description	Qty.
1.	Passenger side arm	1
1.	Driver side arm	1
2.	Aluminum bearing spacer	4
3.	Ball joint	2
5.	Inner bushing sleeve	4
6.	1/2"-13 x 3 1/4" bolt	2
7.	1/2"-13 x 3 1/2" bolt	4
8.	1/2"-13 Nylok nut	6
9.	3/8"-16 x 1 1/4" bolt	2
10.	3/8"-16 Nylok nut	2
11.	Delrin Bushing Half	8

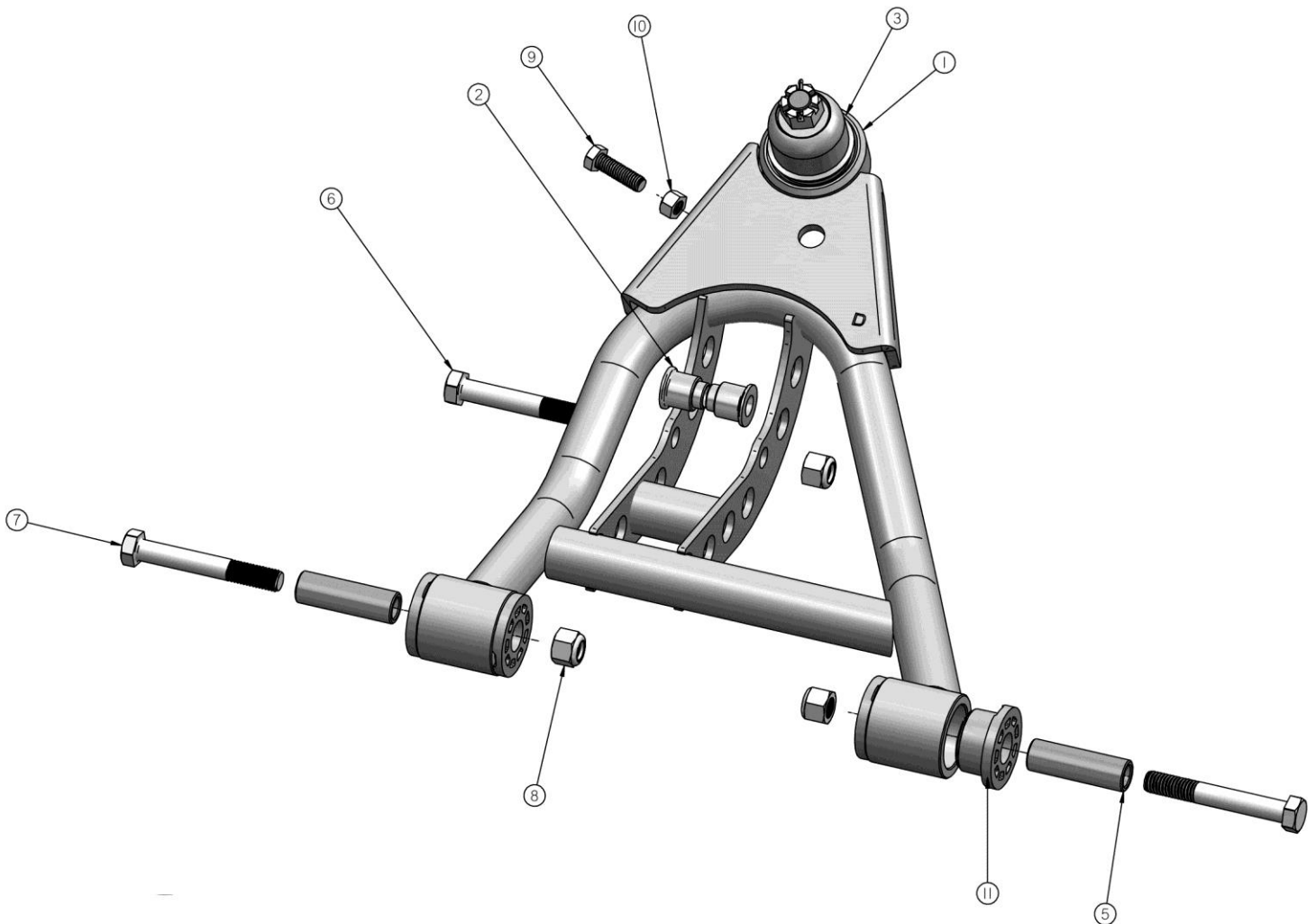



350 S. St. Charles St. Jasper, In. 47546
Ph. 812.482.2932 Fax 812.634.6632

www.ridetech.com

Part # 11163699
67-69 GM "F" Body & 68-74 GM "X" Body Upper StrongArms

Components:

1	90002390	Drivers side arm
1	90002391	Passenger side arm
2	90000908	Ball joint (includes boot, grease fitting, castle nut & cotter pin)
2	90000914	Caster Adjustable Cross shaft w/Hardware
2	70010826	Delrin Bushing – no ledge
2	70010827	Delrin Bushing – small ledge
4	70010759	Delrin Bushing – outer
4	90002737	Cross shaft T-washer
4	70010883	Zero Offset Caster Slugs
2	90001083	Medium bump stop w/ hardware

Installation Instructions



Driver Side Top View

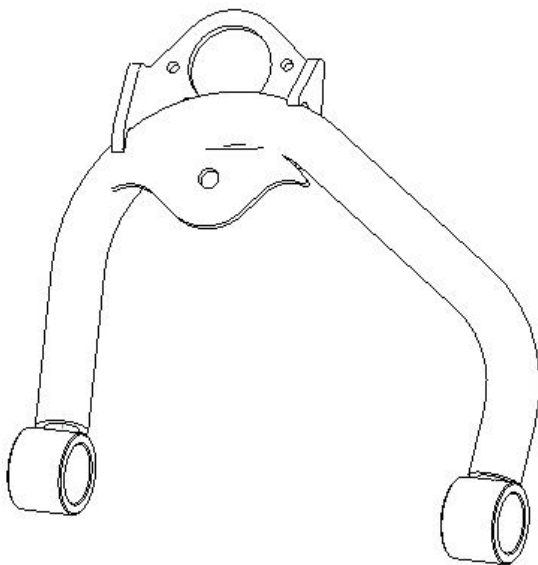

1. On some cars, to remove the upper control arm you must remove the bolts, which are pressed into the frame. We made a slide hammer adapter (a nut with a piece of angle iron welded to it) to aid in removing the bolts.

2. Fasten the upper arm to the frame using the factory hardware. Reinstall the current alignment shims, but **vehicle must be realigned**. This arm was designed with an extra 2 degrees of positive caster with the centered caster slugs. Additional caster slugs are available if more or less caster is desired. By changing the caster slugs you can achieve the caster setting you are wanting without having to run a lot of shims. Caster is explained on the next page.

3. Drop ball joint down through upper arm. Slide ball joint boot over stud, then place boot retainer over the boot. Clamp assembly tight w/ the hardware supplied.

4. Fasten the ball joint to the spindle w/ the new castle nut and cotter pin supplied.

5. Tighten the cross shaft nuts enough to create drag on the delrin bushings, the arm should still move.

6. Lubricate the ball joint w/ standard grease.

STRONG ARMS™

by Air Ride Technologies

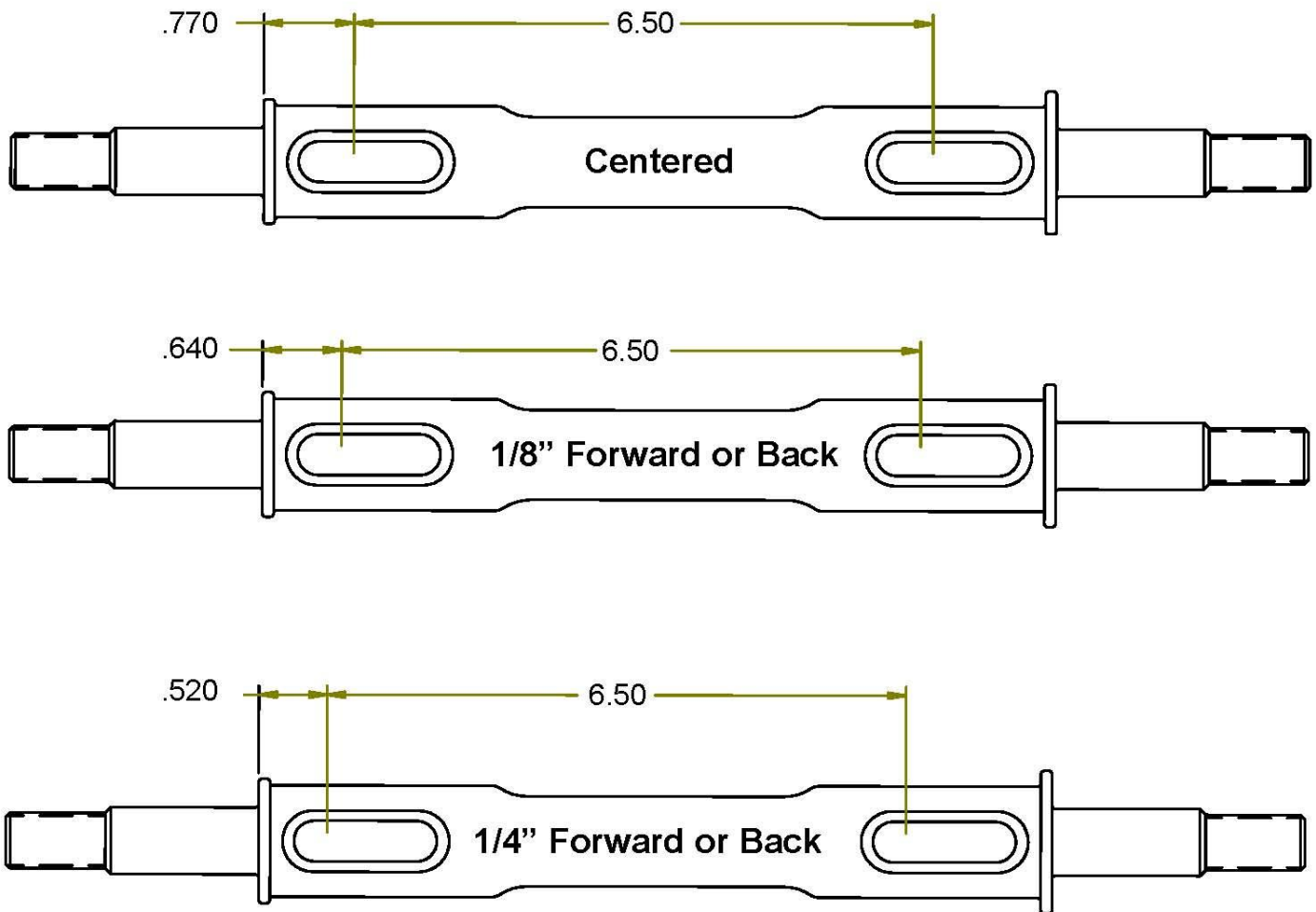

These Strong Arms come equipped with a changeable caster slug setup. This allows you to add or remove caster from the front suspension, if desired. The caster slugs that come in the kit are setup to put the control arm in the centered position, which is approximately 3 degrees of caster. The caster slugs allow you to add or remove caster without having to use a stack of shims. If more or less caster is desired, optional caster slugs can be purchased from your Ridetech dealer or Ridetech.

Caster Explained:

To understand caster you need to picture an imaginary line that runs through the upper ball joint and extends through the lower ball joint. From the side view the imaginary line will tilt forward or backward. The tilting of this imaginary line is defined as caster.

Caster is measured in degrees by using a caster camber gauge. If the imaginary line described above tilts towards the back of the car, at the top, then you will have positive caster. If the imaginary line tilts forward then you would have negative caster.

Positive caster provides the directional stability in your car. Too much positive caster will make the steering effort difficult. Power steering will allow you to run more positive caster. Negative caster requires less steering effort but can cause the car to wander down the highway.

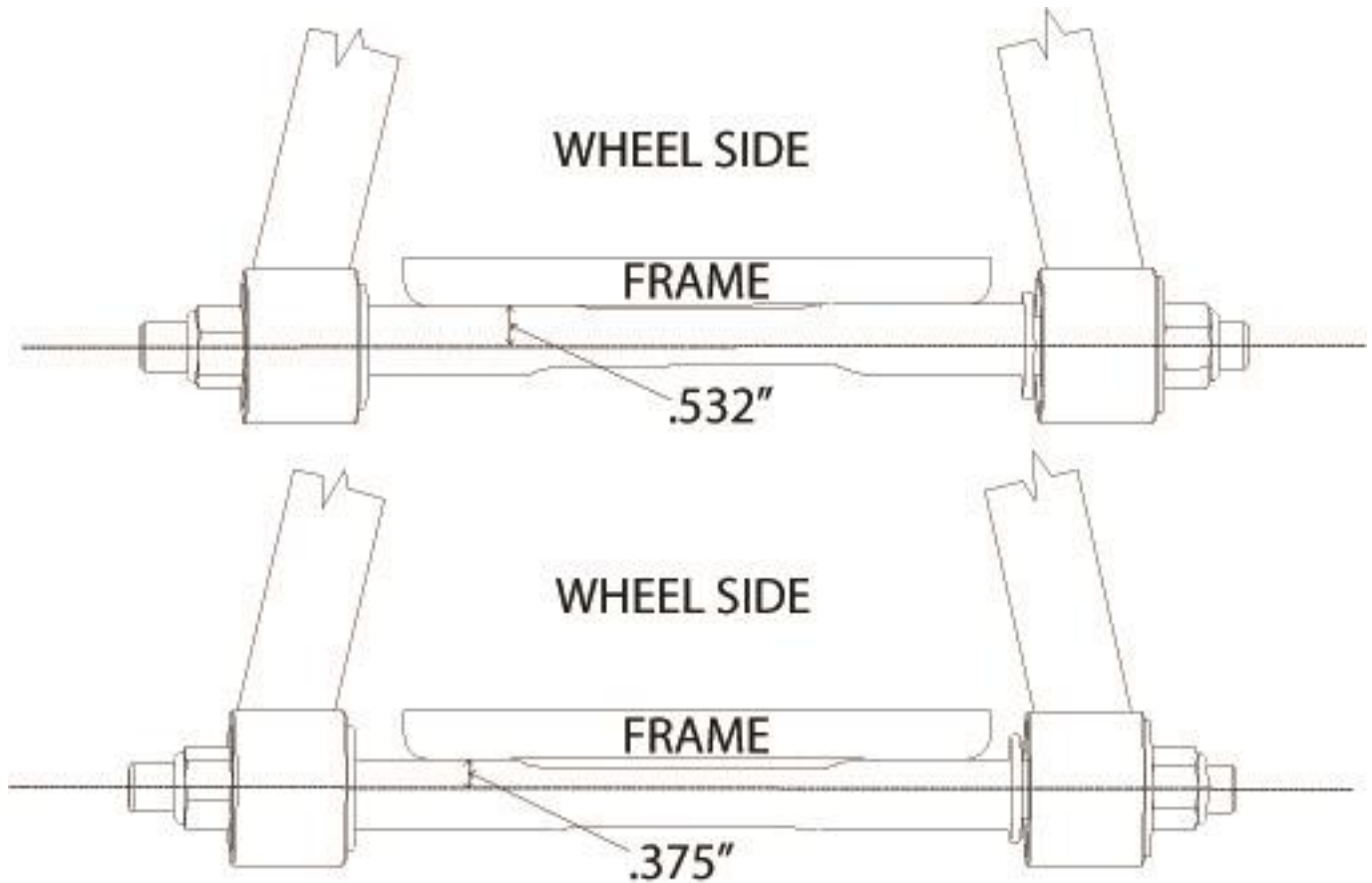

Offset Upper Cross Shaft

The cross shaft that is used in the upper control arm is offset. The offset combined with the caster slug option allows you to achieve the alignment setting you desire with minimal shims. To change the direction that the Icon faces, simply spin the cross shaft in the control arm.

If you are after an aggressive **Track or Autocross Alignment**, bolt the control arm to the frame bracket with the arm offset to the inside of the car (like the top illustration). The Ridetech Icon will be facing the engine.

If a **Street Alignment** is desired, bolt the control to the frame bracket with the arm offset to the outside of the car (like the bottom illustration). The Ridetech Icon will be facing the wheel.

STRONG ARMS™

by Air Ride Technologies

Item #	Description	Qty.
1.	Passenger side arm	1
1.	Driver side arm (Shown)	1
2.	Extension stop	2
3.	Ball joint	2
5.	3/8"-16 Nylok nut & washer	2
6.	1/4"-28 x 7/8" hex bolt	8
7.	1/4"-28 nut	8
8.	Inner Delrin bushing w/ledge	2
9.	Inner Delrin bushing no ledge	2
10.	Outer Delrin bushing	4
11.	T-Washer washer	4
12.	5/8"-18 lock nut	4
13.	Caster Adjustable Cross shaft	2
14.	Caster Slug	4

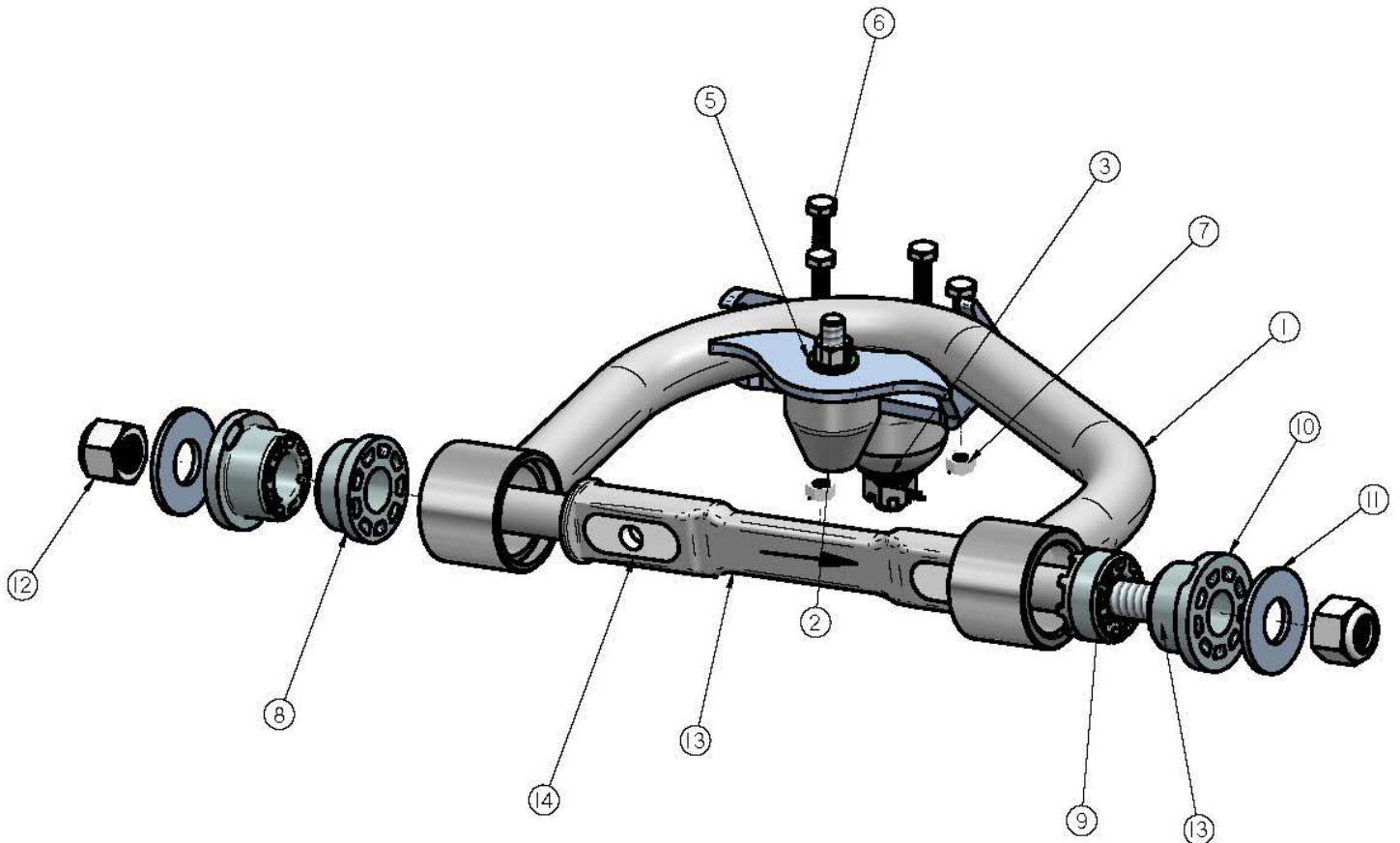



350 S. St. Charles St. Jasper, In. 47546

Ph. 812.482.2932 Fax 812.634.6632

www.ridetech.com

11009300 GM "A" & "F" Body Tall Spindles

2 Tall Spindles

Hardware:

Lower steering arm bolts

(4) 1/2NFX 2 1/2" flathead socket head bolts with Nyloc nuts

Lower caliper bracket bolts

(2) 1/2NFX 2" flathead socket head bolts with Nyloc nuts (Wilwood and Baer Brake kits)

(2) 1/2NFX 2" Grade 8 hex head bolts (use with stock stamped 1/2" thick caliper brackets)

INSTRUCTIONS FOR Ridetech Tall SPINDLES

These spindles will fit '67-69 Camaro, '64-'72 Chevelle, and '68-'74 Nova. They will provide a 2" drop, and are taller than stock to improve the car's cornering ability. The raised upper ball joint will cause the tires to lean into the corner, like a motorcycle, rather than outboard as the shorter stock spindles do. This camber action change also raises the roll center for less body roll, and transfer the car's center of gravity inboard in the turn as well. You will see an appreciable improvement in handling. Standard size anti sway bars will work well with those improvements, without the need for monster sway bars that can cause a harsh ride.

The spindles are modeled after stock disc brake spindles and will accept any disc brake set up designed for those. If your car came with drum brakes, be sure to swap to the appropriate disc brake master cylinder and valving. We have test fitted ECI, Wilwood, Baer, Aerospace, and stock GM kits. The only modification we discovered to be necessary was a small trim on the bottom of the stamped ¼" steel caliper bracket that holds the caliper. It is an area that is not stressed and will not cause any loss of strength. There are variations among the various reproduction the shaft to be flipped in it's bushings for brackets, so the trim will be seen only on some of those.

Stock stamped control arms will accept these spindles, as will any aftermarket arms we have seen. Our own tubular control arms have the upper ball joint plates rotated slightly for better ball joint angles on lowered cars. We also set the ball joint ¾" to the rear of the car to allow more aggressive positive caster settings, as well as to compensate for the normal forward rake seen on hot rods. The upper control arms shaft has a 3/16" offset, allowing the shaft to be rotated in it's bushings for a 3/8" net change in the upper arm's effective length. That design was pioneered by the MOOG company, as many stock autos suffer from a sagged cross member, making it difficult to obtain good alignment numbers. We suggest the alignment be done with 1/8" toe in, ½ degree positive camber, and 3 degrees positive caster with power steering, 2 degrees manual.

It is important to be sure you have the proper steering arms. Many cars were updated to disc brakes in the past by using disc brake and spindle assemblies from a donor car. However, the Chevelle steering arms are front steer, and the tie rod is roughly the same height as the lower ball joint. The Camaro and Nova arms are rear steer, with the outer tie rod end much lower than the ball joint. If the incorrect arms are used, the incorrect height tie rod end will cause major bump steer problems. Our testing of prototype versions of these spindles revealed that a small additional lowering of the mounting holes for the steering arms was necessary to remove the small amount of factory bumpsteer, and to account for the changes made by the taller spindle. We included that enhancement in the production version of your new dropped spindles.



Disassembly of the ball joints from the spindles can be eased by making the simple tool shown in the photo below. A pair of 1 1/2" long bolts are threaded into a matching hex coupler. The ball joint cotter pins are removed, and the hex nuts loosened a couple turns. Place the tool between the ball joint studs, and turn a bolt to expand the tool, gently popping the ball joint studs loose. If your ball joint boots are torn, as often happens when a pickle fork is used to separate the ball joints, NAPA has replacements. The best way to remove the outer tie rod pivot is to loosen the hex nut, and then rap the steering arm boss with a hammer. Tie rod ends pullers are also available if you want to be more gentle on the parts. Do NOT hammer on the tie rod stud itself! Be sure to leave the shock absorber in place to control the spring and prevent it jumping out.

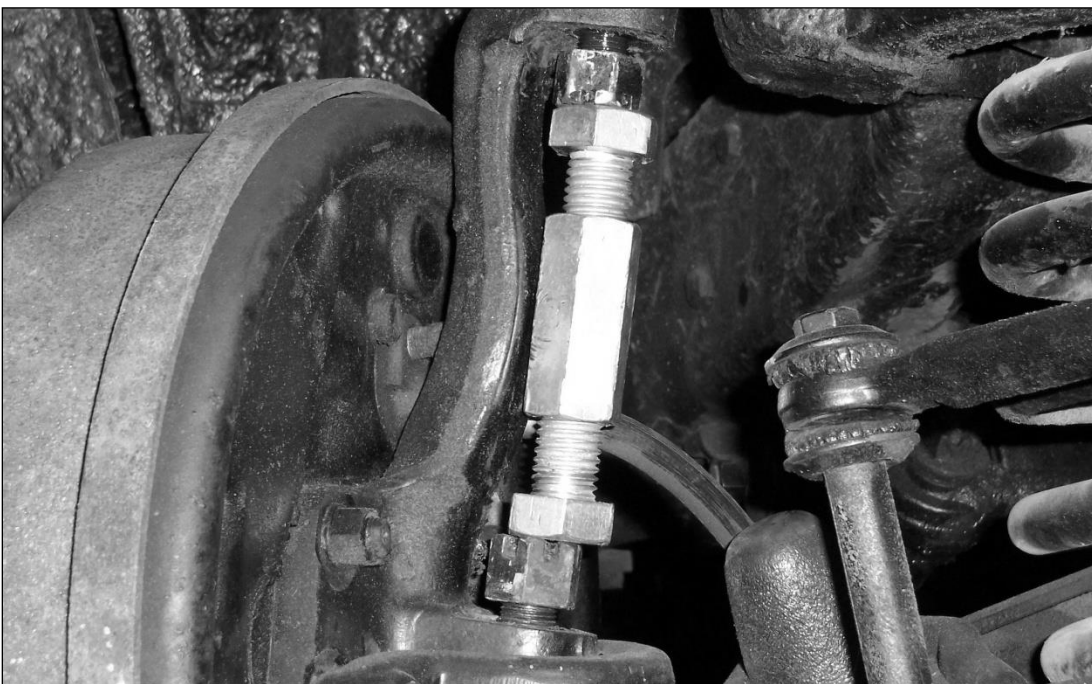

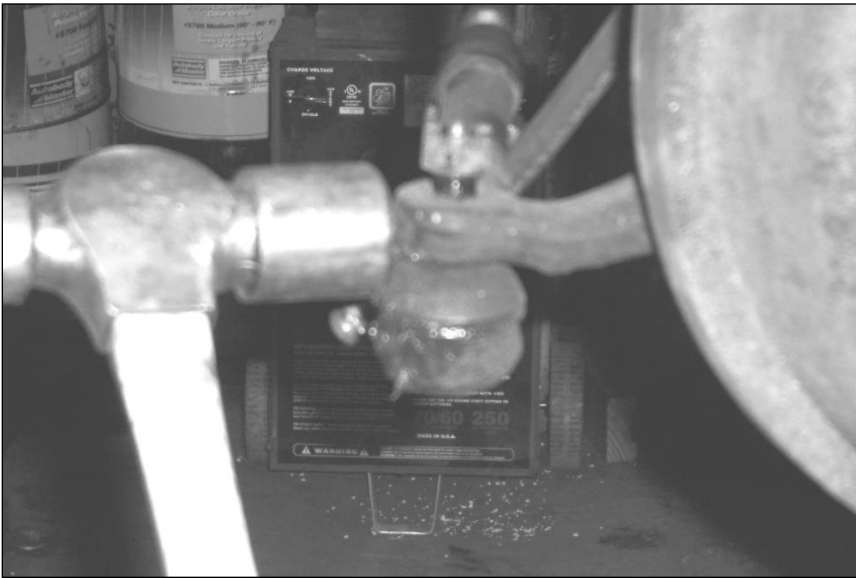

If you remove the calipers but leave the hoses attached, supporting them to avoid stressing the hoses, you won't even need to rebleed the brakes!

Reattach the new spindle, being sure to get the castle nuts tight, and install new cotter pins. Attach the steering arms into the lower holes in the spindles using the 4 supplied 1/2NFx2 1/2" long flathead bolts and Nyloc nuts supplied. The 1/2NFx 2" long flat head bolts and nyloc nuts we supply are for use with Wilwood and Baer brake kit lower bracket bolts. The 1/2NFx2" hex head bolts are used with stock caliper brackets. Reassemble your disc brakes as well. Now would be a good time to clean and grease the bearings.

BEFORE you try moving the car, pump the brakes to reset the pads to the rotors. Rebleed if necessary. Have the alignment shop set the car with 1/2 degree positive camber, 2-3 degrees positive caster, and 1/8" toe in. We're sure you'll be amazed at the difference in handling!



350 S. St. Charles St. Jasper, In. 47546
Ph. 812.482.2932 Fax 812.634.6632

www.ridetech.com

Part # 11169100
**67-69 GM "F" Body & 68-74 GM "X" Body Front MuscleBar
w/ PosiLinks**

Components:

1	90000116	Sway bar	
1	90000121	Driver side arm	
1	90000122	Passenger side arm	
2	90000137	Frame bracket	
2	90001099	Polyurethane frame bushing	
2	90000924	10mm straight PosiLink	
2	90000926	10mm 90 degree PosiLink	
4	90000717	T-bushings	
2	99250001	Grease Zerk fittings – ¼"-20	
2	90001092	Tube of lithium grease	
2	99115001	10 x 1.5 x 36mm stud	In PosiLinks (use Loc-tite)

Hardware Kit: 99010044

4	99112002	10mm Nylok nut	PosiLinks
2	99373003	3/8" SAE flat washer	PosiLinks
4	99311009	5/16" x 1" USS SHCS	Frame bracket
4	99312003	5/16" USS Nylok nut	Frame bracket
8	99313002	5/16" SAE flat washer	Frame bracket
6	99371021	3/8"-16 x 1" FHSCS	Arm to sway bar (Use Loc-tite)
2	99502003	½" SAE Nylok jam nut	Steering arm

MUSCLEbar[™]

by Air Ride Technologies

POSI•Link[™]

11169100 Installation Instructions

1. This sway bar is designed for use with our lower StrongArms. Installation on other arms may require modification.
2. Remove the end links from the factory sway bar. Then remove the bolts attaching the sway bar to the frame.
3. On some cars, the compression stop bracket that is welded to the frame will need to be removed to allow clearance for the sway bar arm.



3. On some cars, the compression stop bracket that is welded to the frame will need to be removed to allow clearance for the sway bar arm.



4. Apply lithium grease to the poly bushing then slide it over the sway bar.



5. Secure the sway bar to the frame with two 5/16" x 1" Socket Head Cap Screws, flat washers and Nylok nuts.

Note: Due to the larger diameter bar, the front hole must be drilled with a 5/16 bit, in front of the factory hole. Use the bracket as a template.



6. On some cars clearance of the cross member may be needed for sway bar clearance.



7. Attach the arm to the bar using three 3/8" x 1" Flat Head Cap Screws. **Blue or Green Loc-tite must be applied to the threads of these bolts.**

Note: With the Arms installed, the lower portion of the MuscleBar should be towards the ground. If it is pointing toward the front of the car, remove the bar and flip it end for end and reinstall the bar and arms.

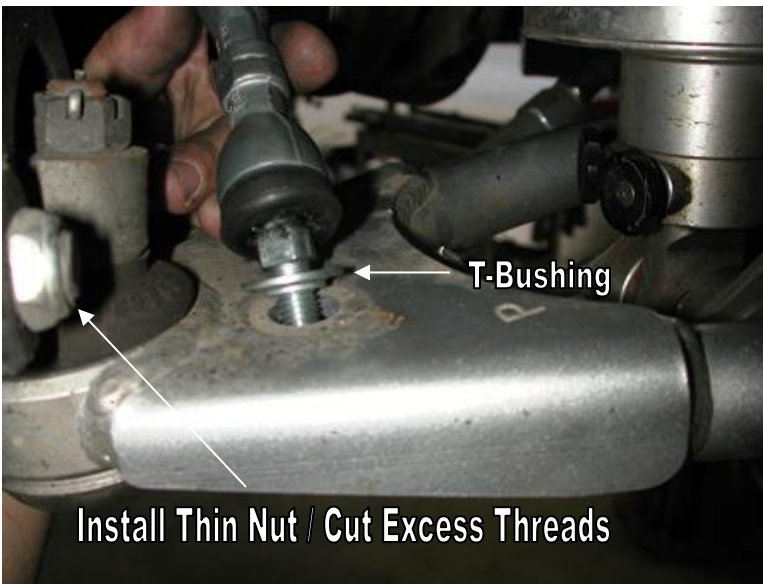

8. The straight end of the PosiLink will attach to the lower control arm. **A "T"-Bushing must be installed on each side of the control arm.** Secure the assembly with a 10mm Nylok nut.

Note: To avoid the front steering arm bolt hitting the PosiLink, a thin Nylok jam nut is installed and the excess threads must be cut off.



9. Attach the other end of the PosiLink to the sway bar arm with a 3/8" flat washer and a 10mm Nylok nut.

10. Check sway bar and PosiLink clearance through full suspension travel, turning the wheel lock to lock. Make sure that the PosiLinks do not bind.

ridetech

350 S. St. Charles St. Jasper, In. 47546

Ph. 812.482.2932 Fax 812.634.6632

www.ridetech.com

Part # 11267199 68-74 Nova Rear AirBar

Components:

1	90002077	Lower axle bracket - Driver
1	90002078	Lower axle bracket - Passenger
2	90001624	Lower billet Shockwave mount
2	90001617	Lower Shockwave stud
4	90002067	Aluminum spacer for stud
2	90000704	Tall Axle tabs (Outside)
2	90000705	Short Axle tabs (Inside)
1	90000703	Upper cradle assembly
2	90001001	Upper bars – TW 7.375" (C-C length 9.250")
1	90001029	Lower bar – WW 24.75" - Passenger side
1	90002328	Lower bar – WW 24.75" - Driver side
2	99250001	1/4"-28 straight grease fitting
2	90001589	Threaded Kevlar line Heim end
2	99752004	3/4"-16 jam nut – for rod end
4	90000552	Aluminum spacer for Heim end
4	90001942	Rubber bushings pressed into bars & rod ends
4	90001090	Poly bushing for lower bar
2	90000526	Lower bar bushing sleeve
2	70010694	Jig brackets for upper bar installation



Hardware Kit: (Part # 99010030)

2	1/2"-13 x 1 1/4" Gr. 5 bolt	Billet mount to axle bracket
2	1/2"-13 x 1 3/4" Gr. 5 bolt	Billet mount to axle bracket
4	1/2"-13 Nylok nut	Billet mount to axle bracket
6	5/8"-11 x 2 3/4" Gr.5 bolt	Bar ends
6	5/8"-11 Nylok jam nut	Bar ends
2	1/2"-13 x 2 1/4" Gr.5 bolt	Upper Shockwave mount
2	1/2"-13 Nylok jam nut	Upper Shockwave mount
16	3/8"-16 x 1" Thread forming bolt	Upper cradle assembly
16	3/8" SAE flat washer	Upper cradle assembly
8	7/16"-20 Nylok nut	Lower axle mount - U bolts
2	3/8"-16 x 3/4" Gr. 5 bolt	Upper bar installation jig
2	3/8"-16 nut	Upper bar installation jig

AirBAR[®]

by Air Ride Technologies

1. Raise the vehicle to a safe and comfortable working height. Use jack stands to support the vehicle with the suspension hanging freely.
2. Support the axle and remove the bump stops, leaf springs, shocks and tail pipes. Refer to the factory service manual for proper disassemble procedures. Keep the factory upper shock bolts, bump stop bolts, U-bolts, and front leaf spring mount and bolts.



3. One more thing needs to be removed before starting the assembly; it's the pinion snubber and mount. For a clean cut use a cut off wheel and smooth any burrs.

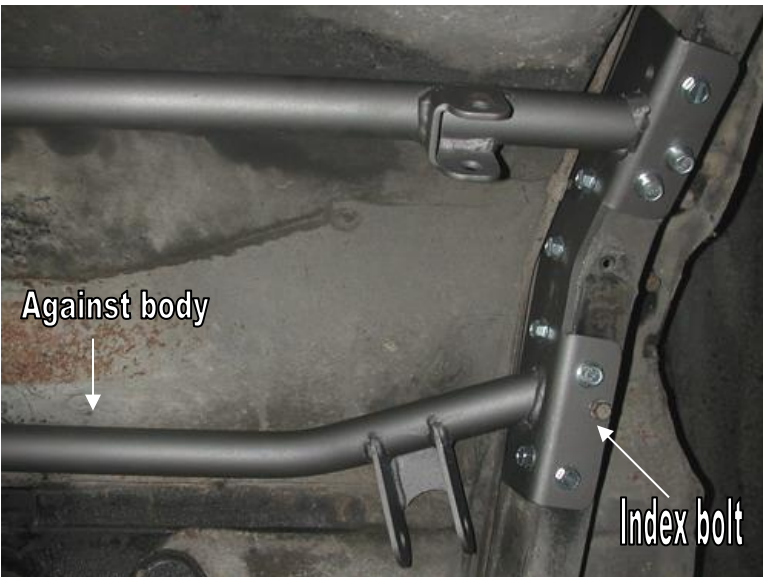

4. Lower the axle enough to slide the upper cradle into place. On most cars the location of the cradle will index off of the factory bump stop bolt hole. If your car has the bump stop beside the frame, slide the cradle forward until the front tube touches the body.

Note: The gas line may need to be moved.

5. A series of self-tapping 3/8" bolts are used to hold the cradle in place. First drill the holes with a 5/16" bit and then thread the bolts into the frame.

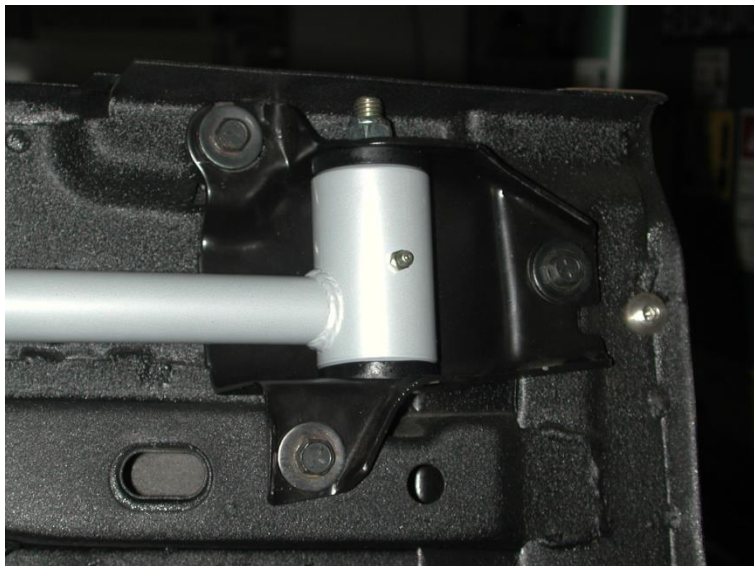

6. Install the large end of the lower bar (the long one) into the factory spring mount using the factory hardware. Do not over tighten this bolt; it should be snug. The bar is offset to the inside of the car for wheel and tire clearance.

7. This bushing is polyurethane and is lubricated at the factory with lithium grease, additional lubrication is not needed. Future lubrication can be done using any non-petroleum based lubricant.

8. Bolt the bar and mount back onto the car using the factory hardware.

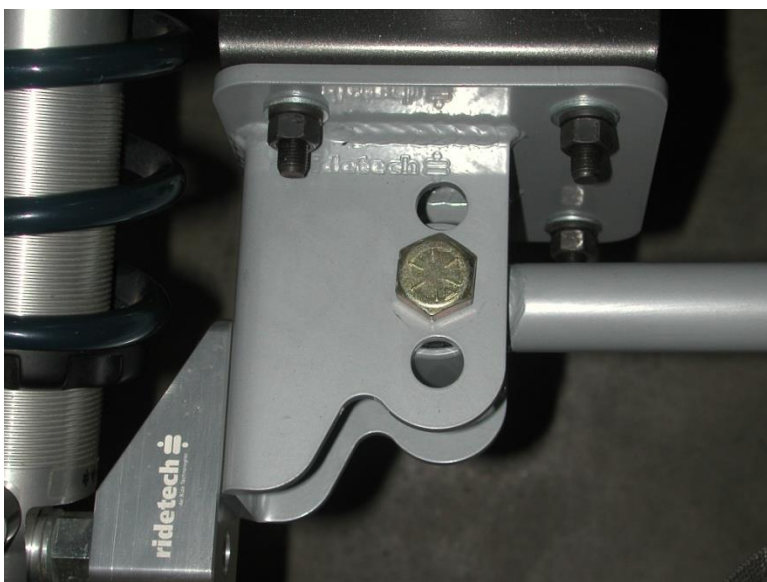

9. The lower axle bracket will be fastened to the leaf spring pad using the factory U-bolts. It is offset to the inside of the car. New 7/16" nylocs are supplied.

10. Bolt the lower Shockwave mount to the lower holes of the axle bracket if you have a monoleaf car. If you have a multileaf car the bottom of the billet mount will be flush with the axle bracket.

11. Swing the lower bar up to the axle bracket and insert 5/8" x 2 3/4" bolt. The standard hole is the center hole like in the picture. Thread 5/8" Nylok onto the bolt but **do not tighten** yet.

12. This end of the bar as well as the upper bars are rubber and do not require lubrication.



13. Check the length of the upper bar; it should be 9 1/4" C-C. Bolt the axle tabs to the upper bar as shown in the picture. (Longer ears to the front) Then place the other end into the cradle. Both ends use a 5/8" x 2 3/4" and should not be fully tightened yet. For now just the let axle tabs sit on the axle.

14. Before welding these tabs to the axle you will need to center the axle and set pinion angle. We used a plum on the outside of the quarter panel to center the axle left to right. Setting the pinion angle is explained on the next page. **This must be done at ride height.**

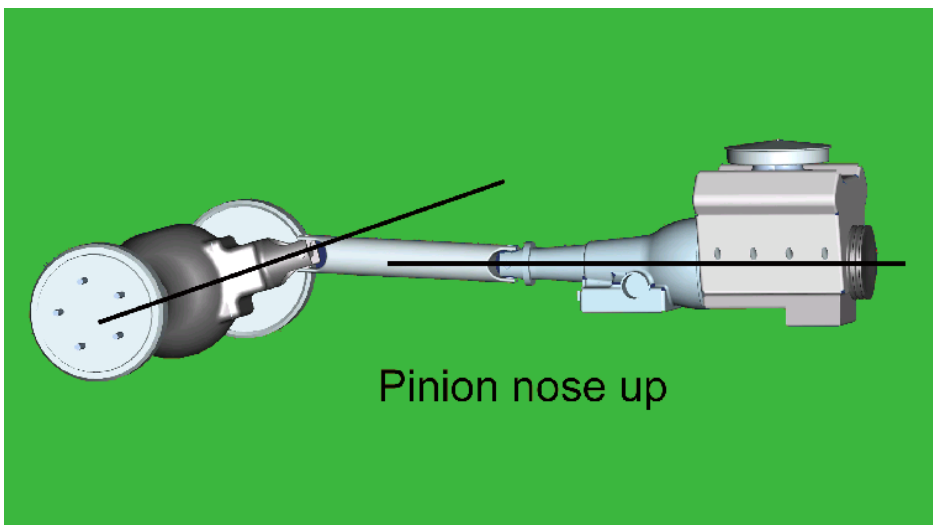
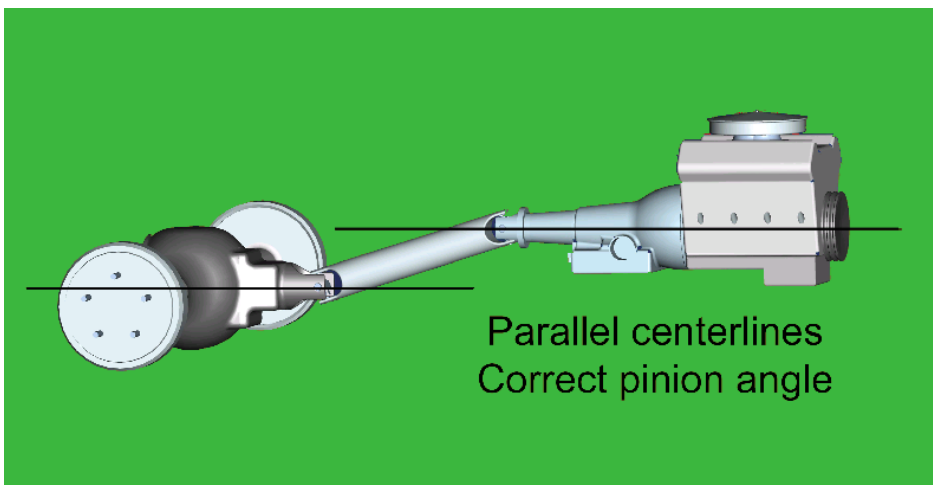
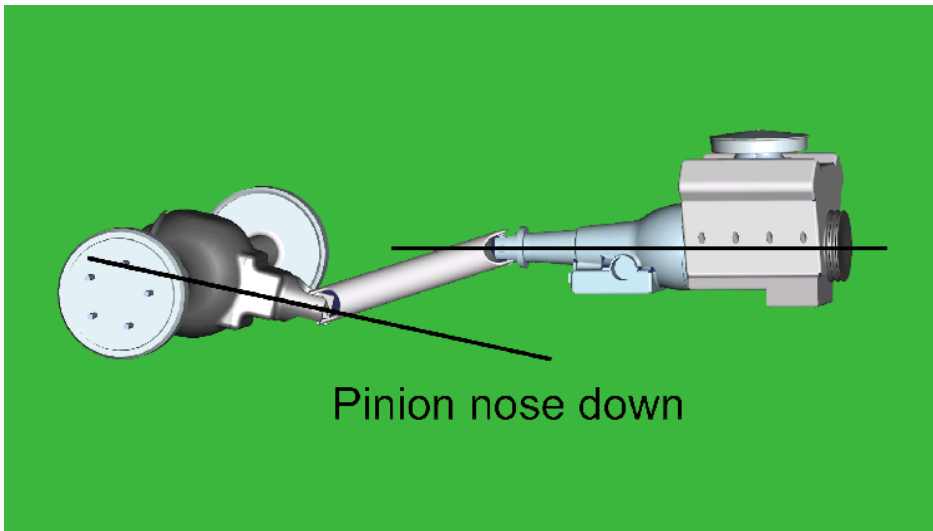

15. How do you set the pinion angle? On a single-piece shaft you want to set it up where a line drawn through the center of the engine crankshaft or output shaft of the transmission and a line drawn through the center of the pinion are parallel to each other but not the same line.

A simple way to do this is to place a digital angle finder or dial level on the front face of the lower engine pulley or harmonic balancer. This will give you a reading that is 90 degrees to the crank or output shaft unless you have real problems with your balancer. At the other end, you can place the same level or angle finder against the front face of the pinion yoke that is also at 90 degrees to the centerline. If you rotate the yoke up or down so both angles match, you have perfect alignment.

Road testing will tell you if you have it right. If you accelerate and you get or increase a vibration, then the pinion yoke is too HIGH. Rotate it downward in small increments of a degree or two until the problem goes away. If you get or increase a vibration when decelerating, then the pinion yoke is too LOW. Rotate it upward to correct it.



16. One helpful trick to help maintain ride height and pinion angle while adjusting is to tack weld a spacer between the axle and the outside of the frame as shown in the picture. This spacer should be 8 3/8" tall giving the Shockwave an eye-to-eye measurement of 14 1/2" to 15".

17. After double-checking pinion angle, ride height, and axle center the tabs can be tack welded. Remove the bar to avoid frying the bushing and finish welding the tabs to the axle.



18. Apply thread sealant to the air fitting and screw it into the Shockwave.

19. Install the Shockwaves using the 1/2" x 2 1/4" bolt and nyloc on top and the 7/16" nyloc on the lower stud mount. There should be a washer on either side of the Shockwave on the stud and none on the upper mount.

20. You can now go back and snug all of the bar end nylocs. This must be done at ride height.

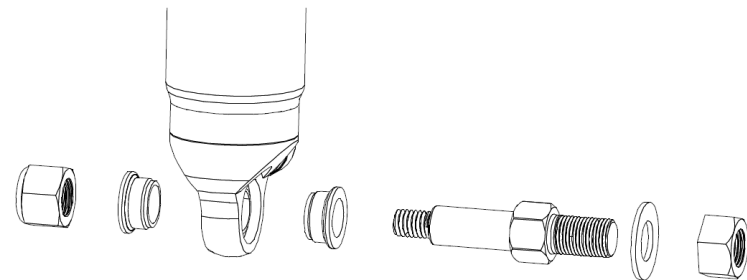

21. You can now remove the spacer from between the axle and frame.

22. The installation is complete but you want to check clearance of the brake lines, parking brake cables, vent tubes and exhaust. For the exhaust you can either install a turndown or reroute the exhaust under the axle.

23. Ride height is 14.5", around 70psi.

Upper Bar Installation Jig

- This jig has been supplied to aid in the installation of the upper 4 link bar. It can be temporarily used to properly align, locate and weld the tabs onto the axle. It will also ensure that the mounting bolts are parallel to the ground.
- Follow the diagram below to set the jig to the same length as the upper bar, use the 3/8" x 3/4" bolt and nuts to set the length.
- Position the axle at ride height. Center the axle left to right between the quarter panels. Set pinion angle.
- Bolt one end of the jig to the cradle using a 5/8" x 2 3/4" bolt.
- Using another 5/8" x 2 3/4" bolt, fasten the axle tabs to the other end. The tabs must be bolted to the **outside** of the jig.
- Swing the bar down letting the tabs rest onto the axle. Trim the brackets as necessary to minimize the gap to be welded.
- Check pinion angle, ride height and axle center. Tack-weld the tabs in place.
- Remove jig and install upper bar.
- Repeat this process for the other side.
- Recheck pinion angle, ride height and axle center. (Sound familiar?)
- After the tabs have been tack welded on both sides, remove the upper bars to avoid melting the rubber bushings. Let the axle drop down for better access to the tabs. Lay 1" welds on the inside and outside of the tabs. Skip around from one side to the other to avoid overheating the tube.

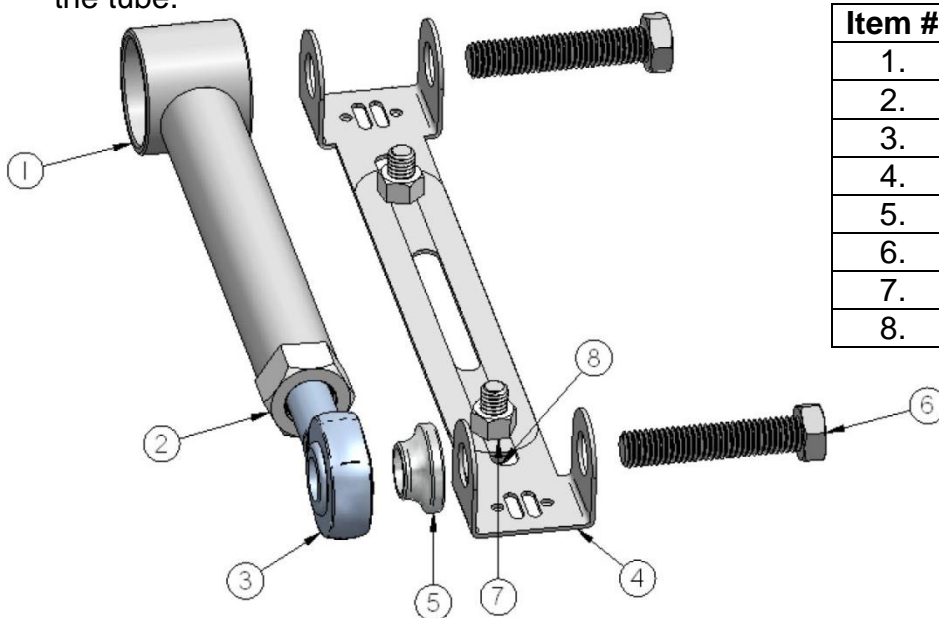

Item #	Description
1.	Upper bar
2.	3/4"-16 jam nut
3.	Heim end
4.	Alignment jig
5.	Aluminum spacer
6.	5/8"-11 x 2 3/4" bolt
7.	3/8"-16 nut
8.	3/8"-16 x 3/4" bolt





350 S. St. Charles St. Jasper, In. 47546

Ph. 812.482.2932 Fax 812.634.6632

www.ridetech.com

Should I weld my AirBar 4 link assembly in?

Since we get this question quite often, it deserves a proper explanation.

The AirBar has been designed for bolt-in installation. We have paid special attention to interfacing with key structural areas of each vehicle, fastening bracketry in at least two planes to properly distribute load paths, and to using appropriate fasteners that roll, rather than cut, threads into the vehicle structure.

Having said that, you could potentially encounter a vehicle that has rust or collision damage in these areas. Or maybe you intend to consistently place the vehicle in severe racing applications with sticky racing slicks and high speed corners. In these cases it is perfectly acceptable to weld the AirBar components into your vehicle. Even in these severe cases we recommend that you install the entire AirBar assembly first [including the fasteners], and then use short 1" long tack welds to secure your installation. Remember that the vehicle structure metal is typically much thinner [.060"-.120"] than the .188" thick AirBar brackets. If you burn through the vehicle sheet metal structure you may end up with an installation that is weaker than before you tried to weld it.

The other reason to weld in your AirBar assembly is...you simply want to. You're a welding kind of guy...that's the way you've always done it...you have the skills and equipment to do it. In that case...weld away with our blessing!

Ride Height

We have designed most cars to have a ride height of about 2" lower than factory. To achieve the best ride quality & handling, the shock absorber needs to be at 40-60% overall travel when the car is at ride height. This will ensure that the shock will not bottom out or top out over even the largest bumps. Measuring the shock can be difficult, especially on some front suspensions. Measuring overall wheel travel is just as effective and can be much easier. Most cars will have 4-6" of overall wheel travel. One easy way to determine where you are at in wheel travel is to take a measurement from the fender lip (center of the wheel) to the ground. Then lift the car by the frame until the wheel is just touching the ground, re-measure. This will indicate how far you are from full extension of the shock. A minimum of 1.5" of extension travel (at the wheel) is needed to ensure that the shock does not top out. If you are more than 3" from full extension of the shock then you are in danger of bottoming out the shock absorber.

Adjusting Spring Height

When assembling the CoilOver, screw the spring retainer tight up to the spring (0 preload). After entire weight of car is on the wheels, jounce the suspension and roll the car forward and backward to alleviate suspension bind.

- If the car is too high w/ 0 preload then a smaller rate spring is required. Although threading the spring retainer down would lower the car, this could allow the spring to fall out of its seat when lifting the car by the frame.
- If the car is too low w/ 0 preload, then preload can then be added by threading the spring retainer up to achieve ride height. On 2.6" - 4" stroke shocks, up to 1.5" of preload is acceptable. On 5-7" stroke shocks, up to 2.5" of preload is acceptable. If more preload is needed to achieve ride height a stiffer spring rate is required. Too much preload may lead to coil bind, causing ride quality to suffer.



350 S. St. Charles St. Jasper, In. 47546
Ph. 812.482.2932 Fax 812.634.6632
www.ridetech.com

Part # 11266510
68-74 GM "X" Body Single Adjustable Rear Coil-Overs
For Use w/ AirBar

Shock Assembly:

- | | | |
|---|----------|-----------------------------------|
| 2 | 24159999 | 5" stroke single adjustable shock |
| 2 | 90002024 | 1.7" eyelet – rebound adjustable |
| 4 | 90001994 | .625" I.D. bearing |
| 8 | 90001995 | bearing snap ring |

Components:

- | | | |
|---|----------|-------------------------------------|
| 2 | 59120175 | Coil spring – 12" long / 175 # rate |
| 2 | 90002222 | Spring retainer kit |
| 4 | 90002043 | Aluminum bearing spacer - .5" I.D. |
| 4 | 70010828 | Delrin Spring Washer |

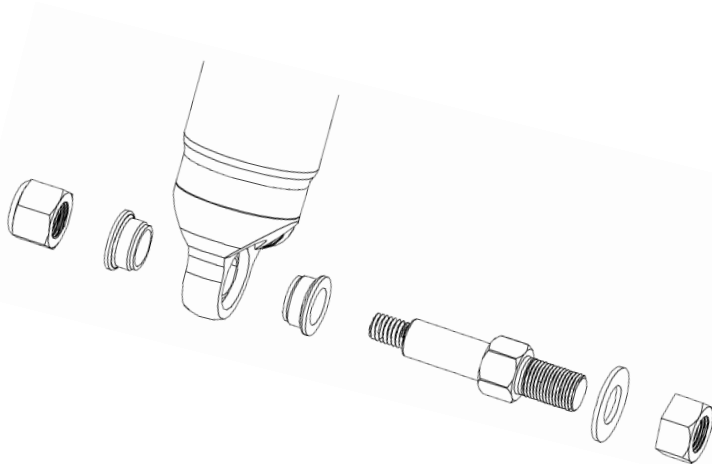

1. Install the Coil-overs using the 1/2" x 2 1/4" bolt and nyloc on top and the 7/16" nyloc on the lower stud mount. There should be .625" Spacers (included in the Airbar) on either side of the Coil-overs on the Stud (included in the Airbar) and .5" Spacers on either side on the upper mount.

Assembly...



First using the supplied lower adjuster nut(90002222) thread the nut onto the shock from the bottom side as seen in figure 1



Next install delrin washers then coil spring over the top of the shock as seen in figure 2



Before the upper spring mount can be installed screw the adjuster knob on the upper eye mount to the firmest setting (clockwise) as seen in figure 3.



Slide the Derlin washer over the spring, Next slide the upper spring mount (90002222) over eyelet as seen in figure 4.



Install upper spring mount retainer clip (90002057) into the groove on the upper eyelet as seen in figure 5. Then reinstall adjuster to complete assembly.



The included set of bearing spacers (900002044) are used to adapt the coil-overs to just about any application. The supplied spacers allow the coil-overs to accept 5/8" or 1/2" bolts.

Shock adjustment 101- Single Adjustable

Rebound Adjustment:

How to adjust your new shocks.

The rebound adjustment knob is located on the top of the shock absorber protruding from the eyelet.

You must first begin at the ZERO setting, then set the shock to a soft setting of 20.



-Begin with the shocks adjusted to the ZERO rebound position (full stiff). Do this by rotating the rebound adjuster knob clockwise until it stops.



-Now turn the rebound adjuster knob counter clock wise 20 clicks. This sets the shock at 20. (settings 21-24 are typically too soft for street use).

Take the vehicle for a test drive.



-if you are satisfied with the ride quality, do not do anything, you are set!



-if the ride quality is too soft increase the damping effect by rotating the rebound knob clock wise 3 clicks.

Take the vehicle for another test drive.



if the vehicle is too soft increase the damping effect by rotating the rebound knob clock wise 3 additional clicks.



-If the vehicle is too stiff rotate the rebound adjustment knob counter clock wise 2 clicks and you are set!

Take the vehicle for another test drive and repeat the above steps until the ride quality is satisfactory.

Note:

One end of the vehicle will likely reach the desired setting before the other end. If this happens stop adjusting the satisfied end and keep adjusting the unsatisfied end until the overall ride quality is satisfactory.