

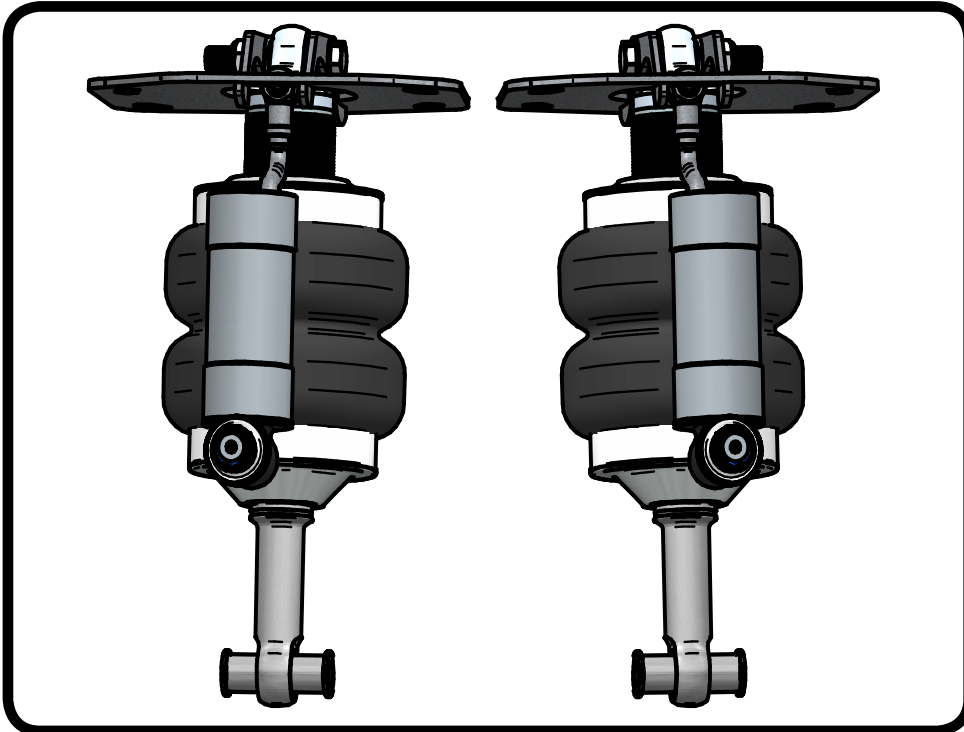

Part # 11505411 -2010-2015 Camaro

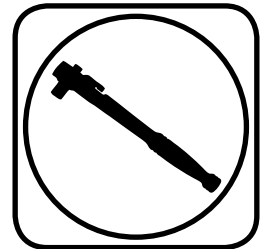

Recommended Tools



2010-2015 Camaro TQ Rear Shockwave System Installation Instructions

Table of contents

Page 2.....	Included components
Page 3.....	Disassembly
Page 4.....	Assembly
Page 5.....	Final Assembly and Shock Adjustment
Page 6.....	Shock Adjustment

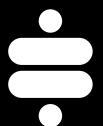



Included ComponentsIn the box

Item #	Part #	Description	QTY
1	24339999	3.6" Stroke TQ Series Shock	2
2	90002025	Shock Eyelet	2
3	90002382	Driver Upper ShockWave Mount	1
3	90002383	Passenger Upper ShockWave Mount	1
4	24190199	1000 Series ShockWave Bellow	2
5	90002043	Upper 1/2" ID Shock Spacer (NARROW)	4
6	90002381	Lower 1/2" ID Shock Spacer (WIDE)	4
	70008913	Bellow Locking Ring (Installed in ShockWave)	2
	99055000	Locking Ring Set Screw (Installed in ShockWave)	2
	31954201	1/4" tube to 1/4" NPT 90 degree Airline fitting	2
	90001994	5/8" ID Bearing (installed in shock and eyelet)	4
	90001995	Bearing Snap Ring (installed in shock and eyelet)	8
	90002221	Reservoir Mounts (Not Shown)	4
	85000003	Hex Wrench for Reservoir Mounting Screws	1
12	99501011	1/2-20 x 2 1/2" Hex Bolt	2
13	99503001	1/2" SAE Flatwasher	4
14	99502008	1/2"-20 Hex Nut	2
	99050000	5mm Socket Head Cap Screws- Reservoir Mounting (Not Shown)	12

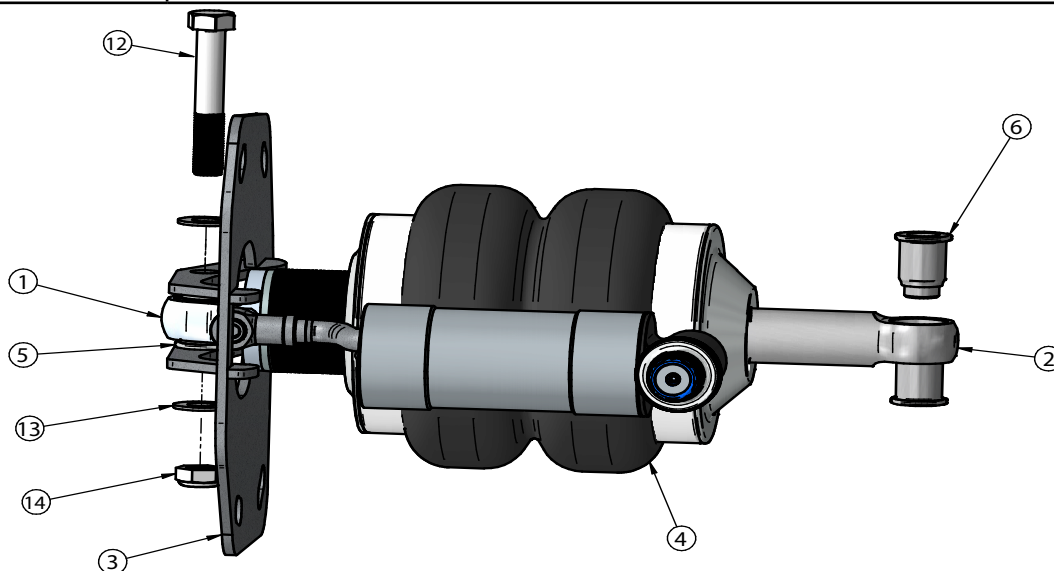



Disassembly

1. Raise the vehicle off the ground and safely support it by something other than the suspension.
2. Disconnect the swaybar linkage from the lower Control Arm.
3. Remove the Bolt attaching the OEM Shock setup from the lower control arm and retain it for reassembly.
4. Remove the (4) bolts attaching the upper shock mount. **Retain the Bolts for reassembly,**
5. Remove the bolt that attaches the Spindle to the lower control arm.
6. Swing the lower control arm down and remove the OEM Shock setup.

Assembly

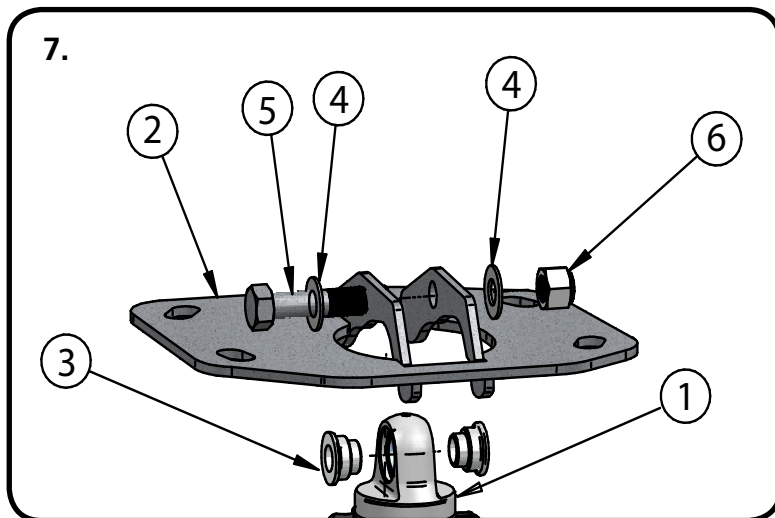

7. Install the Airfitting into the Shockwave using Teflon Tape. Install the shock body side of the ShockWave(1) into the upper mount(2) using a (90002403) spacer(3) installed into the bearing. With the spacers installed into the shock bearing, insert the ShockWave into the mount aligning the holes in the mount with the thru hole in the bearing spacers. Install a 1/2" Flatwasher(4) on the 1/2 x 2 1/2" Hex bolt(5) and insert in the aligned holes. Finish by installing a 1/2" Flatwasher(4) and 1/2" Nylok nut(6) and tightening the nut/bolt.



8. Install the ShockWave/Upper Mount assembly into the car using the factory hardware. There is a Driver and Passenger upper bracket. These brackets are marked accordingly. Once the assembly is installed in the car, rotate the shock eyelet so that the adjuster knob is towards the outside of the car.

Note: You will have to swing the lower arm down to get the assembly into the car.



Assembly

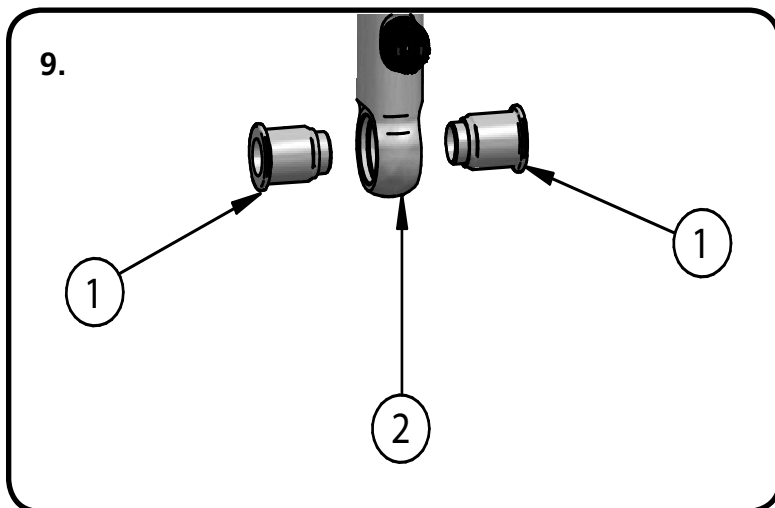

9. Install the (90002381) spacers(1) into the bearing in the ShockWave eyelet(2). Align the ShockWave eyelet with the factory mounting hole and reinstall the factory hardware and tighten.

Final Assembly

10. Reassemble car by reinstalling lower Control arm bolt through spindle and reattaching swaybar linkage to lower control arm and tightening hardware.
11. Repeat the previous steps on the other side.
12. Hook up the Airlines to the ShockWaves. The Air fitting can be clocked by grabbing the Airspring with your hands and rotating it on the shock.



Strut Adjustment

Shock adjustment 101- Single Adjustable

Rebound Adjustment:

How to adjust your new shocks.

The rebound adjustment knob is located on the top of the shock absorber protruding from the eyelet.

You must first begin at the ZERO setting, then set the shock to a soft setting of 20.



-Begin with the shocks adjusted to the ZERO rebound position (full stiff). Do this by rotating the rebound adjuster knob clockwise until it stops.



-Now turn the rebound adjuster knob counter clock wise 20 clicks. This sets the shock at 20. (settings 21-24 are typically too soft for street use).

Take the vehicle for a test drive.



-If you are satisfied with the ride quality, do not do anything, you are set!



-If the ride quality is too soft increase the damping effect by rotating the rebound knob clock wise 3 clicks.

Take the vehicle for another test drive.



-If the vehicle is too soft increase the damping effect by rotating the rebound knob clock wise 3 additional clicks.



-If the vehicle is too stiff rotate the rebound adjustment knob counter clock wise 2 clicks and you are set!

Take the vehicle for another test drive and repeat the above steps until the ride quality is satisfactory.

Note:

One end of the vehicle will likely reach the desired setting before the other end. If this happens stop adjusting the satisfied end and keep adjusting the unsatisfied end until the overall ride quality is satisfactory.

STILL HAVE QUESTIONS?

Tech line hours

Monday - Friday

8AM - 6PM (EST) 812-482-2932



Shock Adjustment

Shock adjustment 101- Triple Adjustable

Triple Adjustable:

Step One: High Speed Compression



- High speed compression adjustments are used in both street driving and track tuning.
- Begin with the shocks adjusted to the ZERO high speed compression position (full stiff). Do this by rotating the high speed compression adjuster (large knob) clockwise until it stops.
- Now turn the high speed compression adjuster knob counter clock wise 20 clicks. This sets the shock at 20. (settings 21-24 are typically too soft for street use. For typical street driving the high speed compression adjuster will remain at setting 20.

Step Two: Low Speed Compression

Low speed compression adjustment is what is typically felt during street driving.



- Begin with the shocks adjusted to the ZERO low speed compression position (full stiff). Do this by rotating the low speed compression adjuster (small knob) clockwise until it stops.
- Now turn the low speed compression adjuster knob counter clock wise 20 clicks. This sets the shock at 20. (settings 21-24 are typically too soft for street use). Take the vehicle for a test drive.
- if you are satisfied with the ride quality, do not do anything, you are set!
- if the ride quality is too soft increase the damping effect by rotating the low speed compression knob clock wise 3 clicks.

Take the vehicle for another test drive.



- if the vehicle is too soft increase the damping effect by rotating the low speed compression knob clock wise 3 additional clicks.
- If the vehicle is too stiff rotate the low speed compression adjustment knob counter clock wise 2 clicks and you are set!

Take the vehicle for another test drive and repeat the above steps until the ride quality is satisfactory.

Step 3:

Adjust rebound according to Single Adjustable instructions.

Note:

One end of the vehicle will likely reach the desired setting before the other end. If this happens stop adjusting the satisfied end and keep adjusting the unsatisfied end until the overall ride quality is satisfactory.