

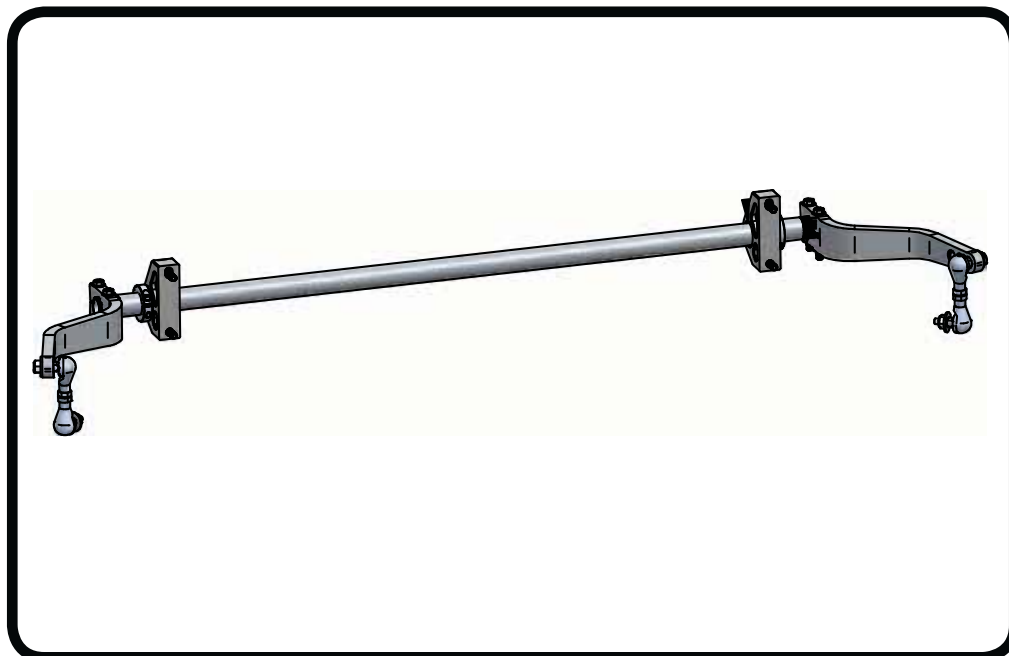

Part # 11509102 - 2010-2015 Camaro Rear MuscleBar

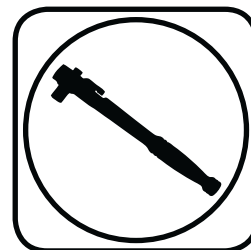

Recommended Tools

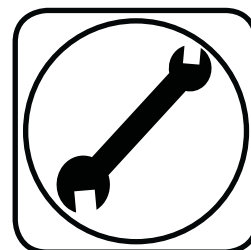

2010-2015 Camaro Rear StrongArm MuscleBar Installation Instructions

Table of contents

Page 2..... Included components and Hardware List

Page 3..... Getting Started

Page 4..... MuscleBar Installation

Page 5..... Final Tightening and Adjusting

This kit is designed to be used with Ridetech StrongArms.





Major ComponentsIn the box

Item #	Part #	Description	QTY
1	70012206	Splined Rear MuscleBar	1
2	90002132	MuscleBar Arms	2
3	70012148	MuscleBar Mount	2
4	70011928	Locking Ring	2
5	70012205	Delrin Bushing	2
6	90000926	90 Degree, 10mm PosiLink	2

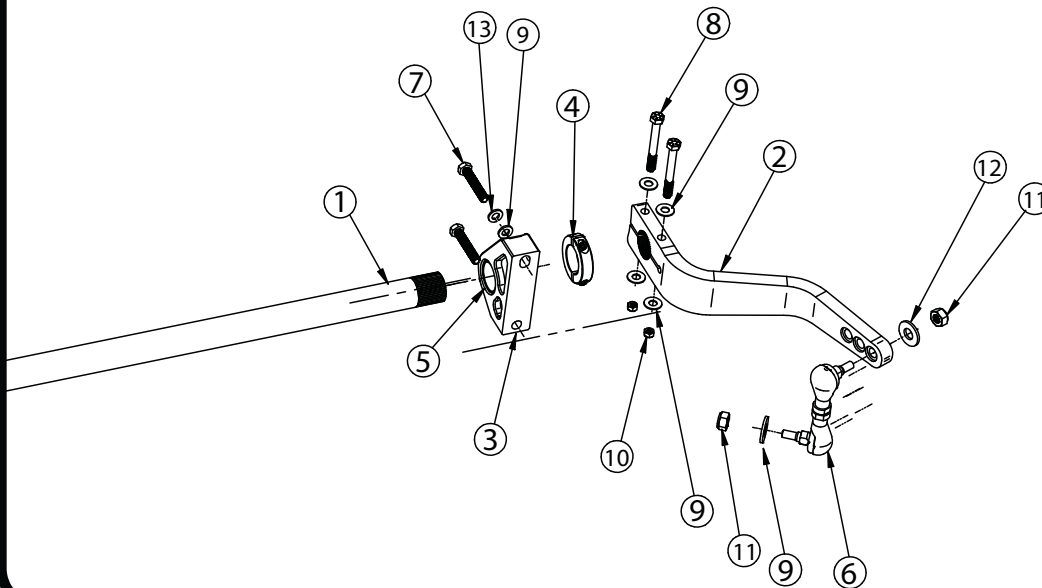

Hardware ListIn the box (Kit # 99010055)

Item #	QTY	Part Number	Description	Location
7	4	99081004	M8-1.25 x 50mm Hex Bolt	Bracket to Frame
8	4	99311024	5/16"-18 x 2 3/4" Hex Bolt	SwayBar Arm Pinch Bolt
9	12	99313001	5/16" SAE Flatwasher	SwayBar Arm Pinch Bolt, Bracket to Frame
10	4	99312003	5/16"-18 Nylok Nut	SwayBar Arm Pinch Bolt
11	4	99112002	M10-1.5 Nylok Nut	PosiLink to Swaybar and Control Arm
12	4	99373003	3/8" SAE Flatwasher	PosiLink
13	4	99083002	M8 Lockwasher	Bracket to Frame



Getting Started.....

Congratulations on your purchase of the Ridetech Rear MuscleBar. This kit has been designed to give your Camaro excellent handling along with a lifetime of enjoyment. Some of the key features of this MuscleBar: PosiLinks - The PosiLink makes the reaction of the swaybar instantaneous. Tuneability - this Musclebar has 3 positions to aid in the tuning your cars handling.

Note: This MuscleBar is designed to be used with the Ridetech StrongArms.

Note: THE ARMS CAN BE CLOCKED ON THE CAR OR THEY CAN BE CLOCKED ON A FLAT SURFACE BEFORE INSTALLATION. DO THIS BY SLIDING THE ARMS ON THE BAR USING A FLAT SURFACE TO KEEP THEM PARALLEL WITH EACH OTHER. AFTER YOU HAVE THE ARMS INSTALLED PARALLEL, MARK THE ARMS AND THE BAR. ALIGN THE MARKS WHEN INSTALLING THE ARMS AND THEY WILL BE CLOCKED THE SAME.

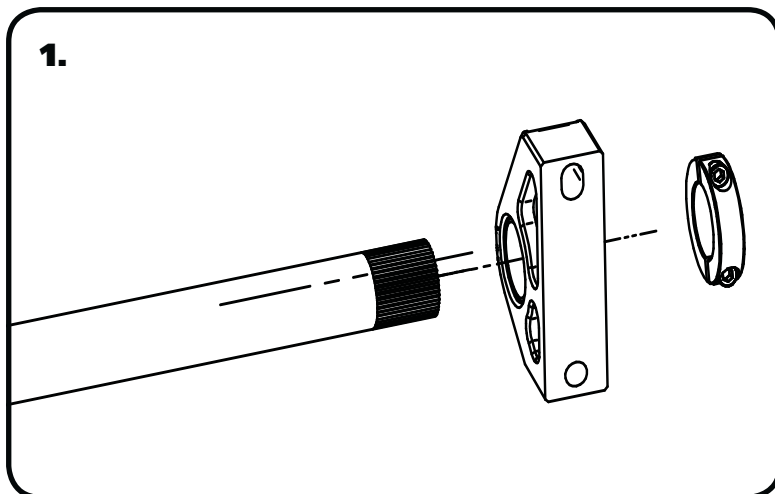

1. Install both Bushing Mounts onto the Splined Bar with the Flange side of the Inner Bushing facing out. With the Bushing Mount slid onto the bar, install the Locking Ring, but do not tighten.



2. Bolt the assembly into the OEM Swaybar location, with the LONG SIDE UP, using (4) 5/16" SAE Flatwashers, (4) 8M Lockwashers and (4) 8M-1.25 x 50mm Hex Bolts. The mounts are bolted with the long side on the top. Run the bolts down until they touch, but DO NOT TIGHTEN.



MuscleBar Installation



3. Center the Splined Bar by measuring each side and sliding it in the mounts until both sides measure the same. Once the Splined Bar is centered, tighten the Mounting Blocks. Next, slide the Locking Ring up against the Bushing and tighten the Locking Ring.

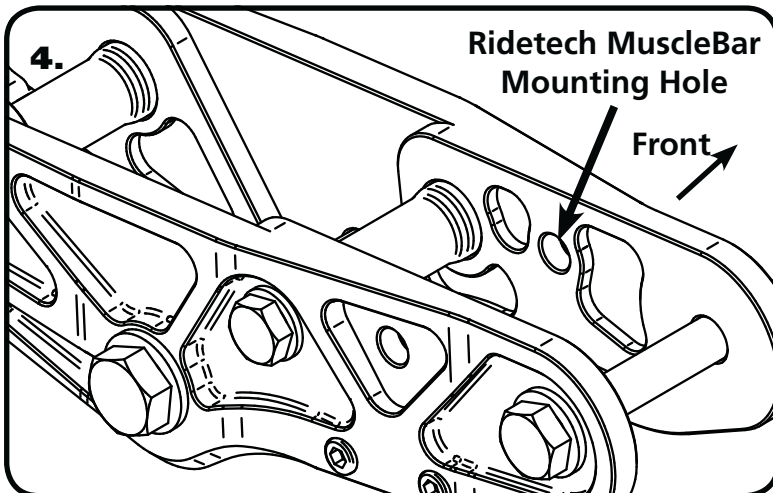

4. Use Diagram 5 to determine the correct PosiLink assembly for each side. Attach the PosiLinks to the StrongArm in the location shown in Diagram 4. Install 3/8" Flatwasher and 10mm Nylok nut on each PosiLink and tighten down.

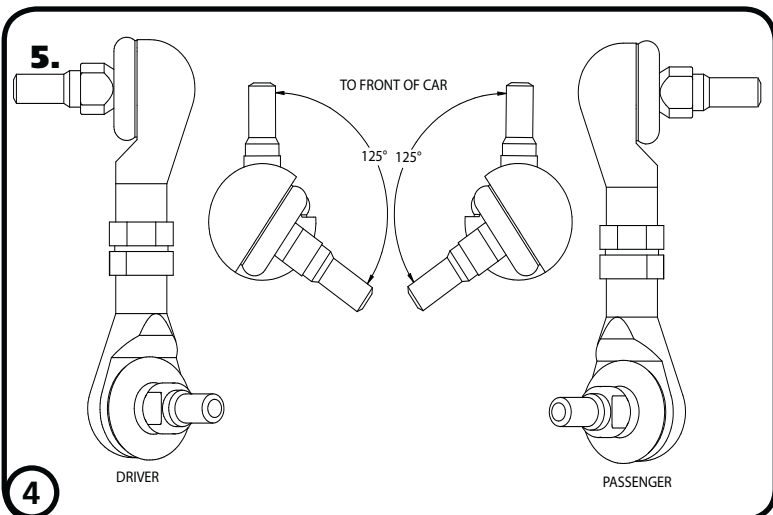

5. Diagram 5 shows the difference between the Driver and Passenger PosiLinks.



Final Tightening



6. The PosiLink can be used to get the arms clocked the same. Install one Arm on the Drivers Side and rotate it up and down until you can insert the PosiLink in the center hole. On the Passenger Side, install the arm on the Sway Bar. Try to insert the PosiLink in the center hole. Remove the Arm from the Splines and move it one Tooth at a time, reinstalling the arm until the PosiLink will go in the center hole easily.

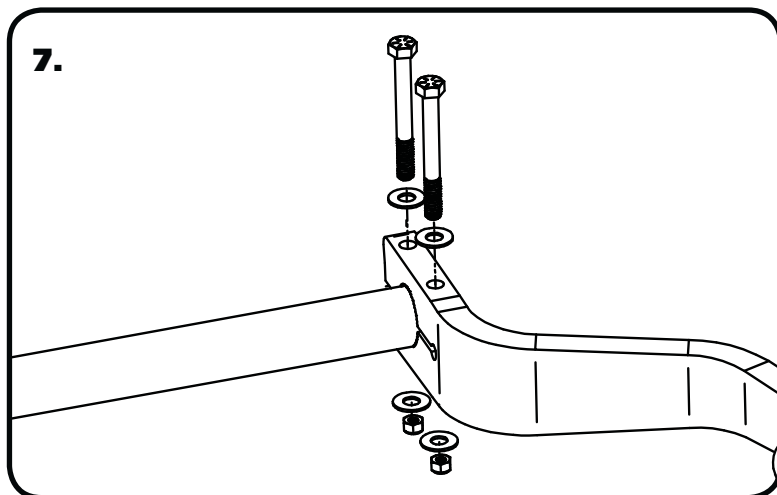

7. After the arms are installed, insert (2) 5/16" x 2 3/4" bolts with a 5/16" washer on each, through the Clamping Holes in the Arms. Install a 5/16" Flatwasher and 3/8" Nylok on the Bolt and Torque to 25 ftlbs. It will be necessary to torque each bolt multiple times.

8. After installation, be sure that the Musclebar will go through the entire suspension travel without contacting anything.

The MuscleBar has 3 positions to aid in the tuning of your car's handling. We start in the center position and tune from there. The Position to the front of the car will make the Musclebar softer. The position to the rear of the car will make the MuscleBar stiffer.

Note: The Delrin Bushings are Self-Lubricating and will not need to be lubricated.

STILL HAVE QUESTIONS?

Tech line hours

Monday - Friday

8AM - 6PM (EST) 812-482-2932

www.ridetech.com

812-482-2932