



Part # 11720110/11720115 - 2019 UP GM 1/2 Ton 2WD/4WD Lowering Kit

Front Components

111723699 Front Upper Control Arms
11723110/11723115 2WD/4WD Front CoilOver Kit

Rear Components

11729511 Rear Flip Kit with HQ Series Shocks

Recommended Tools



19 Up GM 1/2 Ton 2WD/4WD Lowering Kit Installation Instructions

Table of contents

Page 2-15.....Front Installation Instructions
Page 16-35..... Rear Installation Instructions
Page 36..... Alignment & Shock Adjustment

We recommend installing some components in conjunction with each other. On the front, the CoilOvers and Upper Control Arms should be installed at the same time. In the rear, install the Flip Kit in conjunction with the HQ Series Shocks.

IF YOU ARE PLANNING TO TOW WITH YOUR NEW LOWERING KIT, WE RECOMMEND THE RIDETECH AIR LEVELING KIT 11724099.

www.ridetech.com





Part # 11723110/11723115 - 2019 UP Silverado 2wd/4wd HQ Front CoilOvers

Recommended Tools

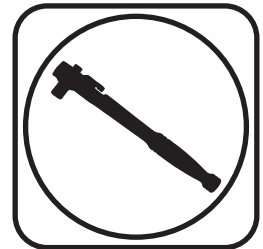

2019 UP Silverado Front CoilOvers Installation Instructions

Table of contents

Page 3-4.....	Included Components
Page 5.....	Disassembly and Getting Started
Page 6.....	Disassembly
Page 7.....	Mount Installation
Page 8-9.....	Installation of CoilOver Assembly
Page 10.....	CoilSpring and Shock Adjustment

THIS KIT IS DESIGNED TO REPLACE THE OEM SHOCK/SPRING SETUP.



Major ComponentsIn the box

Item #	Part #	Description	QTY
1	90003435	Upper CoilOver Mount Assembly	2
2	90003436	Lower CoilOver Mount Assembly - Driver	1
3	90003437	Lower CoilOver Mount Assembly - Passenger	1
4	982-10-805	5.2" Stroke HQ Series Shock	2
5	90002025	1.7" Shock Eyelet Assembly	2
6	90001994	5/8" ID Bearing (installed in shock eyelet/body)	4
7	90001995	Bearing Snap Ring (installed in shock eyelet/body)	8
8a	90001447(kit)	Lower Spring Adjuster Nut - 234-15-200	2
8b	90001447(kit)	Adjuster Nut Locking Screw - 99050001	2
8c	90001447(kit)	Upper CoilSpring Retaining Plate - 90002070	2
8d	90001447(kit)	CoilSpring Plate Retaining Ring - 038-01-006-A	2
9	90002043	.500" x .365" Shock Bearing Spacers	8
10	70010828	Delrin Spring Washer	4
11	59120550 (2WD) or 59100650 (4WD)	Coilspring 12" (2WD) 550lb - 2WD or Coilspring 10" (4WD) 650lb - 4WD	2 or 2

HARDWARE LIST Kit # 99010214

Item #	Part Number	Description	QTY
LOWER MOUNT			
12	99431033	7/16"-14 x 2 1/4" Hex Bolt	4
13	99432010	7/16"-14 Nylok Nut	4
14	99433005	7/16" SAE Flat Washer	8
UPPER MOUNT			
15	99371005	3/8"-16 x 1 1/4" Hex Bolt	6
16	99372001	3/8"-16 Nylok Nut	6
17	99373002	3/8" SAE Flat Washer	12
SHOCK TO SHOCK MOUNTS			
18	99501064	1/2"-13 x 2 3/4" Hex Bolt	4
19	99502009	1/2"-13 Nylok Nut	4
20	99503014	1/2" SAE Flat Washer	8



Major ComponentsIn the box

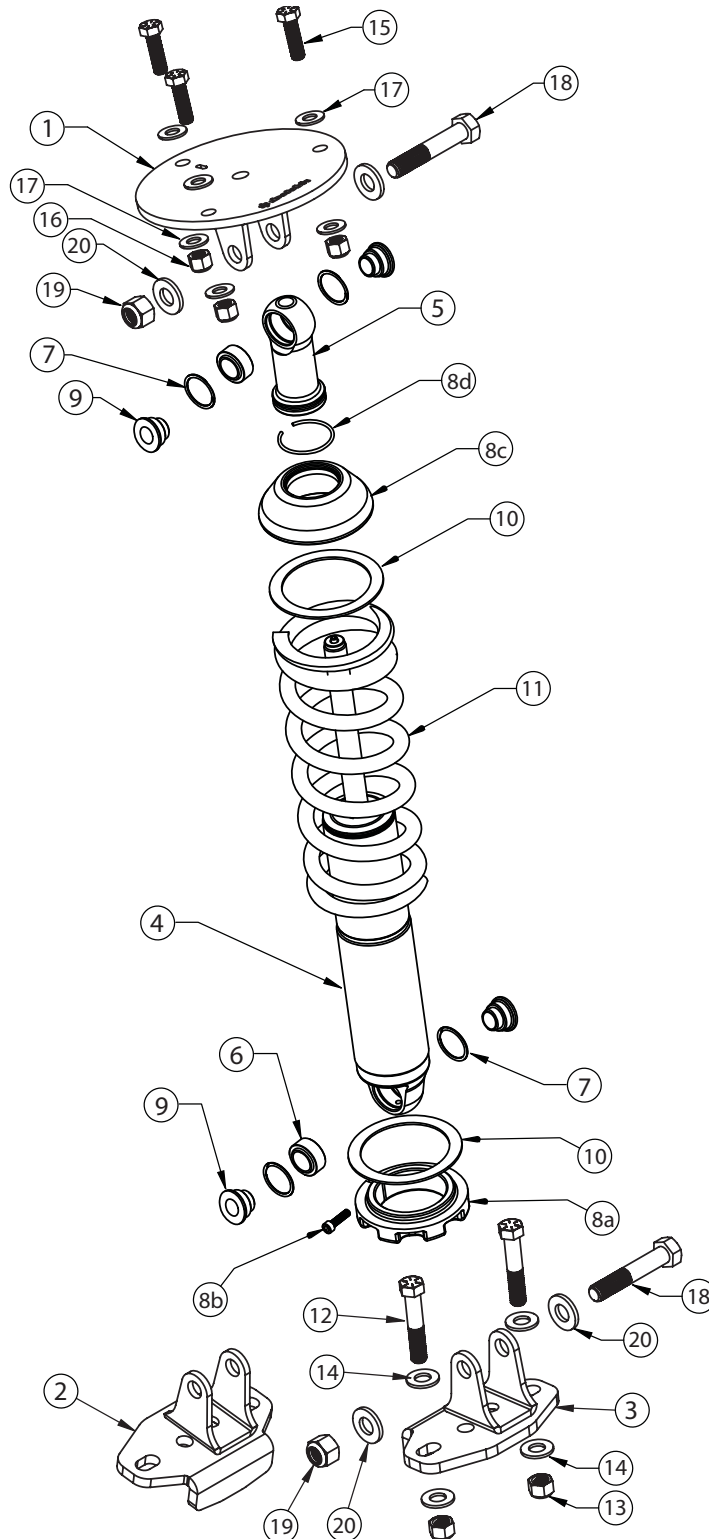



Alignment Note.....

THE LOWER YOU SET THE FRONT RIDE HEIGHT OF YOUR SILVERADO, THE HARDER IT WILL BE TO GET AN ALIGNMENT THAT IS WITHIN SPECIFICATIONS.

Disassembly

This CoilOver System is Designed to replace the factory Shocks and Springs.

The front OEM Shock and Spring assemblies will need to be removed from the front of the truck. **DO NOT DISASSEMBLE THE SHOCK/SPRING ASSEMBLY.**

1. Raise the vehicle and support it by the frame, allowing the suspension to hang freely.
2. You will need to raise and lower the suspension to simplify installation. We use a jack to do this.
3. When replacing the upper control arms, replace them in conjunction with the coilovers.

Getting Started.....

4. The CoilOvers need to be assembled before putting the shocks in the mounts. Assemble the shocks and springs using the instructions below.

NOTE: The Upper Mounts are not side specific so they are the same for both sides of the truck.

CoilOver Assembly...



1

First, using the supplied lower adjuster nut (803-00-199) thread the nut onto the shock from the bottom side as seen in figure 1. Remove the plastic pellet that is in the split of the adjuster nut.



2

Next, install a delrin washer then coil spring over the top of the shock as seen in figure 2.



3

Before the upper spring mount can be installed screw the adjuster knob on the upper eye mount to the upper eye mount to the firmest setting (clockwise) as seen in figure 3. Then remove the Knob by holding it while removing the center screw.



4

Once the knob is removed slide a Delrin washer over the eyelet. Next, slide the upper spring mount (803-00-199) over eyelet as seen in figure 4.



5

Install upper spring mount retainer clip (803-00-199) into the groove on the upper eyelet as seen in figure 5. Then, reinstall adjuster to complete assembly.

Install the locking screw in the adjuster nut before setting spring preload, but DO NOT tighten until the spring preload has been set.

NOTE: Remember to adjust the shock valving before driving, the shock is currently set to full stiff.



Disassembly



5. With the suspension supported with a jack, remove the 3 upper shock/spring retaining nuts.



6. Remove the lower nut from the lower sway bar linkage. This will allow the suspension to be lowered easier for CoilOver removal and installation.



7. Remove the 2 lower shock/spring mounting bolts. The OEM shock/spring can now be removed from the truck.



Mount Installation

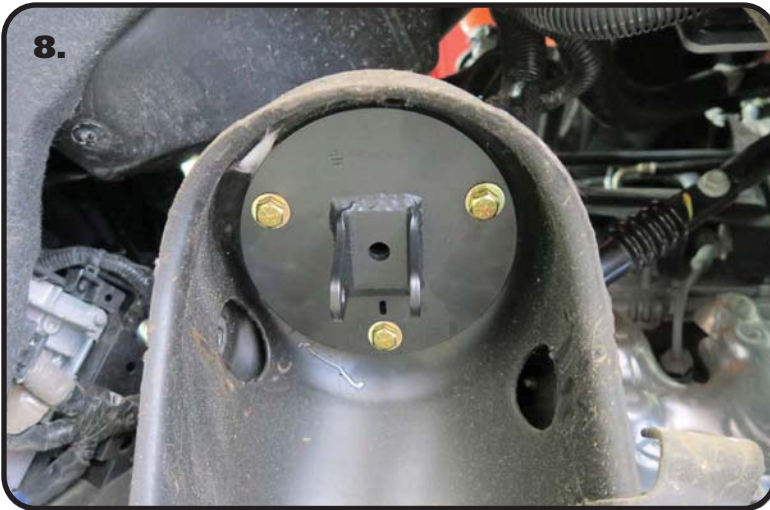

8. Install a 3/8" flat washer on each of (3) 3/8"-16 x 1 1/4" hex bolts. Align the mounting holes of the upper mount with the mounting holes in the frame. THE SLOT IN THE UPPER MOUNT, NEEDS TO BE TOWARD THE FRAME. The mounting bolts need to be installed with the threads pointing up. Insert a bolt/washer in each hole. Install a 3/8" flat washer and 3/8"-16 nylok nut on the threads of each bolt sticking through the frame. Torque the hardware to 45 ftlbs.

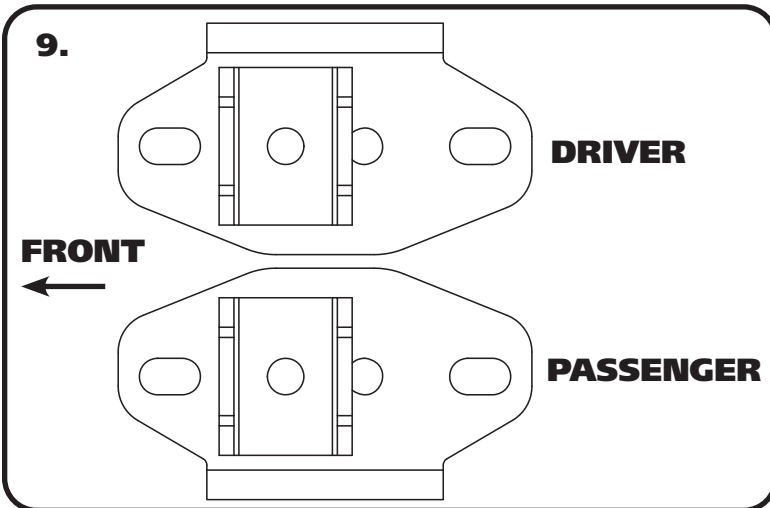

9. THE LOWER MOUNTS ARE SIDE SPECIFIC. **IMAGE 9** SHOWS A TOP VIEW OF BOTH MOUNTS. The shock mount is offset to the front of the truck.



10. Align the lower mount with the OEM shock mounting holes. The mount needs to be positioned with the bent tab to the inside of the truck. The shock mounting tabs need to be offset to the front of the truck. Install a 7/16" flat washer on each of (2) 7/16"-14 x 2 1/4" bolts. Insert the bolt/washers through the mount and control arm. Install a 7/16" flat washer and 7/16"-14 nylok nut on the threads of each bolt. Torque to 70 ft-lbs.



Installation of CoilOver Assembly

11.

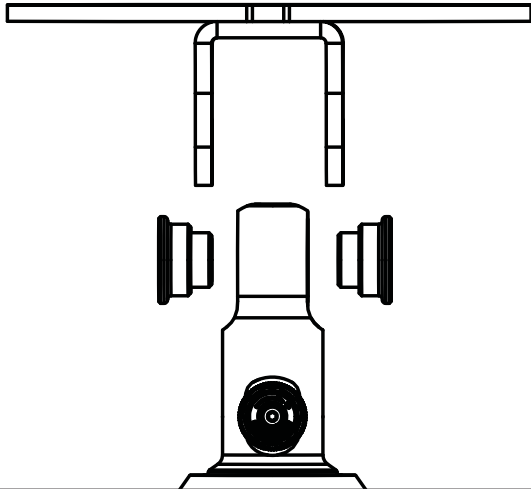

11. Insert the small diameter of the aluminum shock spacers into each side of the shock bearing in the eyelet.

12.

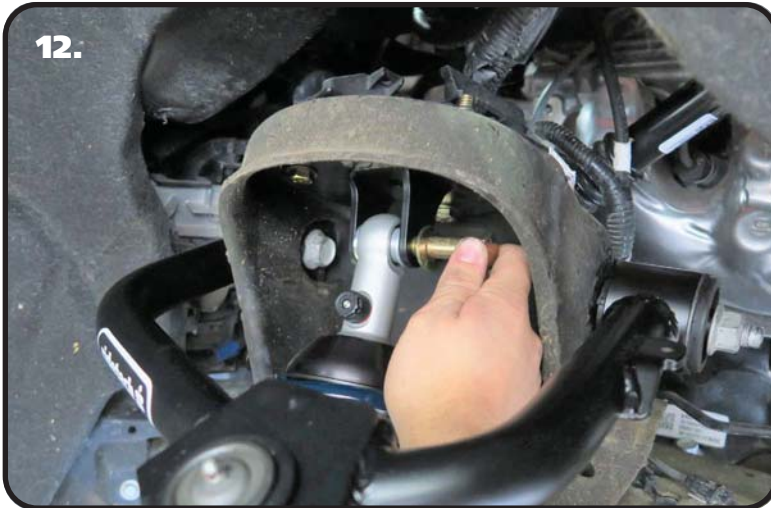

12. Insert the shock eyelet into the upper mount. Line up the shock bearing/spacers hole with the mounting holes of the upper mount. Insert a 1/2"-13 x 2 3/4" bolt through the mount/shock. **MAKE SURE THE ADJUSTMENT KNOB IS FACING OUT TO THE WHEEL.**

13.



13. Install a 1/2" flat washer and 1/2"-13 nylok nut on the threads of the bolt that are sticking through the mount.



Installation of CoilOver Assembly



14. Insert the small diameter of the aluminum shock spacers into each side of the shock bearing in the shock body. Insert the shock body into the lower mount. Line up the shock bearing/spacers hole with the mounting holes of the lower mount. Insert a 1/2"-13 x 2 3/4" bolt through the mount/shock.

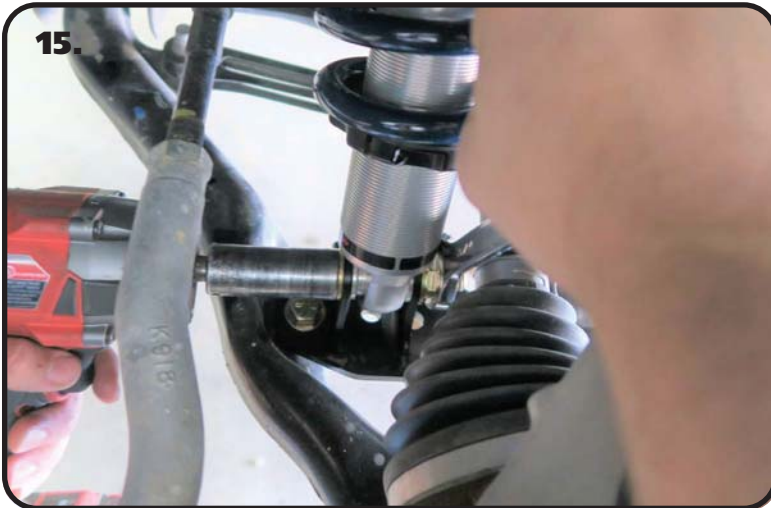

15. Install a 1/2" flat washer and 1/2"-13 nylok nut on the threads of the bolt that are sticking through the mount. Torque the upper and lower mounting hardware to 75 ftlbs.



16. Image 16 shows the CoilOver installed. Repeat steps 4-15 on the other side of the truck. Preload the springs of the CoilOver 1/2" to start. You may need to adjust the amount of preload in the spring, but this will be determined after the truck has been sat on the ground. Refer to **Page 9** for spring adjustment.

17. Install the upper control arms. Refer to the instructions supplied with the upper control arms..

Reattach the sway bar linkage.



CoilSpring & Shock Adjustment

Adjusting Spring Height

When assembling the CoilOver, screw the spring retainer tight up to the spring (0 preload). Measure from the bottom of the adjuster nut to the flat of the shock. Thread the adjuster up the shock 1/2" to preload the spring. Tighten the locking screw that is in the adjusting nut to lock the adjuster in place. After entire weight of truck is on the wheels, jounce the suspension and roll the truck forward and backward to alleviate suspension bind.

- If the truck is too high with 1/2" of preload, reduce the amount of preload that is on the spring by threading the adjusting nut down the shock body.
- If the truck is too low with 1/2" preload, then preload can then be added by threading the spring retainer up to achieve ride height.
- Lock the adjusting nut in place by tightening the locking screw that is the adjusting nut.

Shock Adjustment 101- Single Adjustable

Rebound Adjustment:

How to adjust your new shocks.

The rebound adjustment knob is located on the top of the shock absorber protruding from the eyelet.

You must first begin at the ZERO setting, then set the shock to a medium setting of 12.



-Begin with the shocks adjusted to the ZERO rebound position (full stiff). Do this by rotating the rebound adjuster knob clockwise until it stops.



-Now turn the rebound adjuster knob counter clock wise 12 clicks. This sets the shock at 12. (settings 21-24 are typically too soft for street use).

Take the vehicle for a test drive.



-if you are satisfied with the ride quality, do not do anything, you are set!

-if the ride quality is too soft increase the damping effect by rotating the rebound knob clock wise 3 clicks.

Take the vehicle for another test drive.



-if the vehicle is too soft increase the damping effect by rotating the rebound knob clock wise 3 additional clicks.



-If the vehicle is too stiff rotate the rebound adjustment knob counter clock wise 2 clicks and you are set!

Take the vehicle for another test drive and repeat the above steps until the ride quality is satisfactory.

Note:

One end of the vehicle will likely reach the desired setting before the other end. If this happens stop adjusting the satisfied end and keep adjusting the unsatisfied end until the overall ride quality is satisfactory.



Part # 11723699 - 2019 up Silverado Front Upper StrongArms

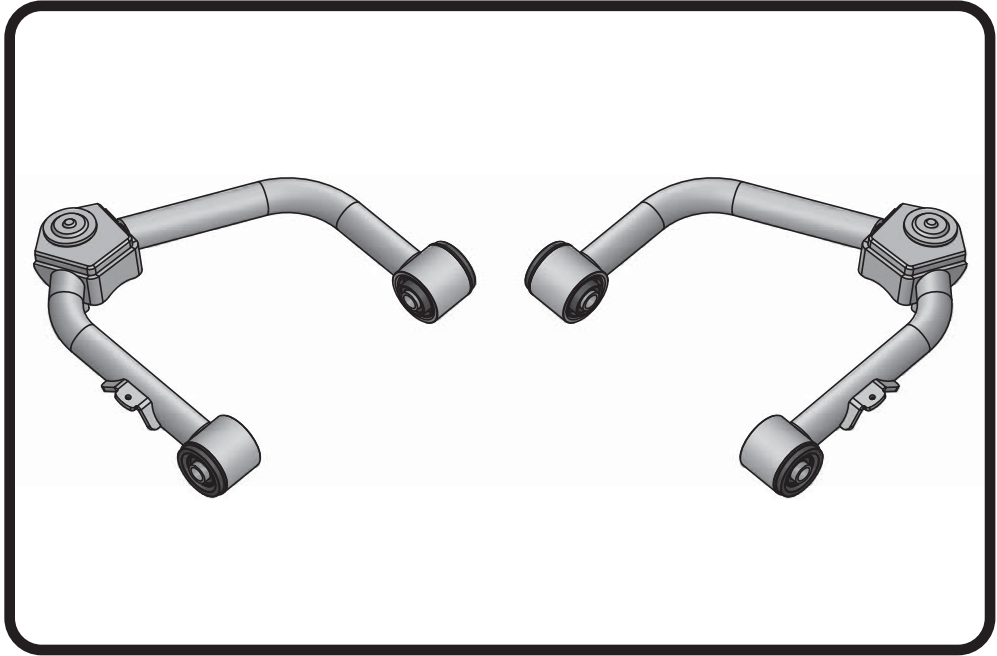

Recommended Tools



**2019 up Silverado Upper StrongArms
Installation Instructions**

Table of contents

- Page 12..... Upper Control Arm Components & Hardware Kit
- Page 13..... Getting Started
- Page 14..... Upper Control Arm Installation
- Page 15..... Upper Control Arm Installation & Alignment



Upper Control Arm ComponentsIn the box

Item #	Part Number	Description	QTY
1	90003459	Driver Upper Control Arm	1
2	90003460	Passenger Upper Control Arm	1
3	90003269	Upper Control Arm Bushing - Tenneco MB05B714620	4
4	70016040	Upper Ball Joints - Proforged 101-10502/Moog K500340	2

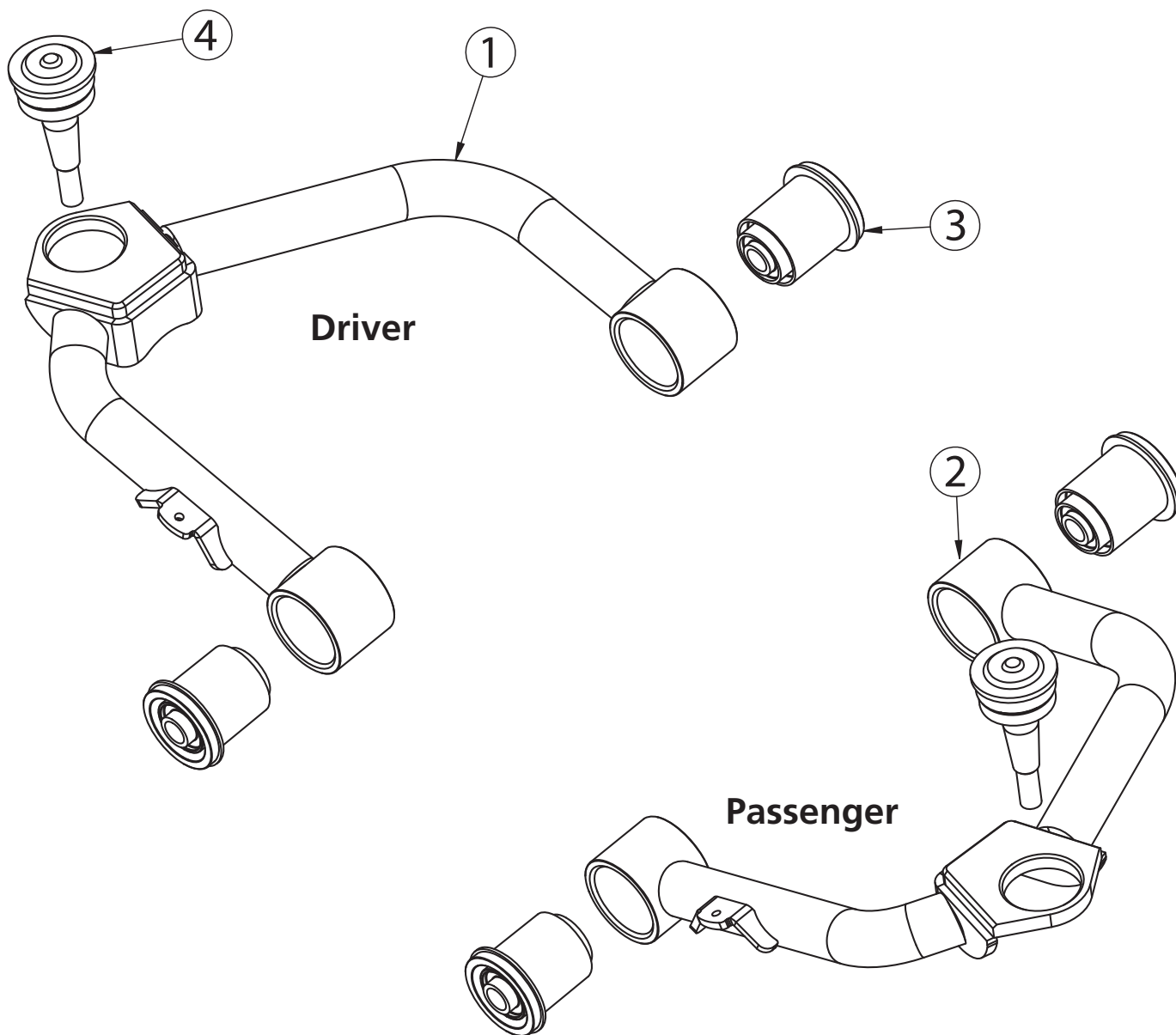



Getting Started.....

Congratulations on your purchase of the Ridetech 2019 up Silverado StrongArms. These StrongArms have been designed to give your Silverado excellent handling along with a lifetime of enjoyment. Some of the key features of the StrongArms: Ball Joint angles have been optimized for the lowered ride height, Control arm length has been optimized for the lowered ride height.

Installation

1. Remove the entire upper control arms from the truck. Retain the OEM hardware for installation of the new control arms. If you are replacing the shock/spring assembly, install them in conjunction with the upper control arms. Refer to the CoilOver instructions for installation.



2. Remove the brake line tab from the upper arm. Retain the hardware for reinstallation.

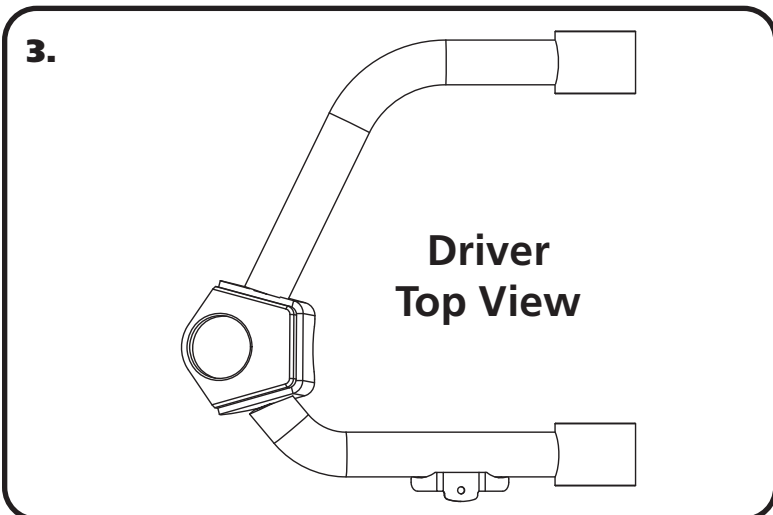

3. The upper control arm is attached to the factory mount using the factory hardware. The driver side arm is shown in **Figure "3"**. The ball joint on the arm is oriented to the rear of the truck. The brake line tab on the control arm will be to the REAR of the control arm.



Upper Control Arm Installation



4. The upper control arm is attached in the factory mount using factory hardware. The driver side arm is shown in **Figure "3, 4 & 5"**. Line up the through holes of the bushings with the OEM holes.



5. Reinstall the OEM bolts. Snug the hardware down for now. The upper control arm bolts need to be torqued to spec with the truck at ride height.



6. Insert the pin of the upper ball joint into the spindle.



Upper Control Arm Installation



7. Install the ball joint nut on the ball joint pin.

Torque Specs:

Lower Ball joint - 50 ftlbs and tighten to line up cotter pin.

Install the cotter pin after tightening the ball joint nut.



8. The locating tab of the bracket line bracket will need to be flattened out. We used an adjustable wrench to bend it flat.



9. Attach the brake line bracket to the tab of the upper control arm using the OEM hardware. Torque to 92 in-lbs.



Part # 11729511 - 2019 up GM 1/2 Ton Axle Flip Kit

Recommended Tools

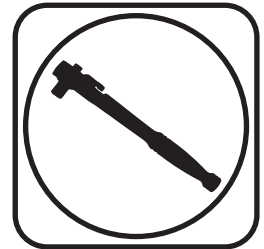
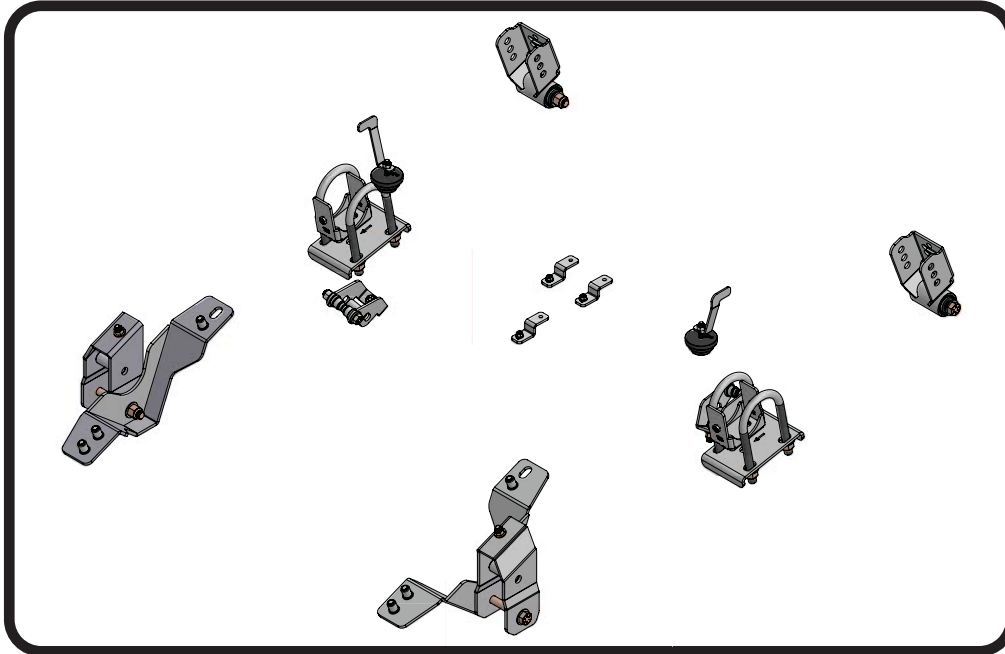

2019 up GM 1/2 Ton Axle Flip Kit Installation Instructions

Table of contents

Page 17.....	Included Components & Getting Started
Page 18-20.....	Disassembly
Page 21.....	Brake Line Relocation Bracket Installation
Page 22.....	Shackle Installation
Page 22-27.....	Front Leaf Spring Bracket Installation
Page 28.....	Shackle Installation
Page 28-31.....	Hanger & Flip Bracket Installation
Page 32.....	Bump Stop Installation
Page 32-33.....	Shock Relocation Bracket Installation
Page 34.....	Shock Installation
Page 35.....	Final Tightening & Shock Adjustment





Major ComponentsIn the box

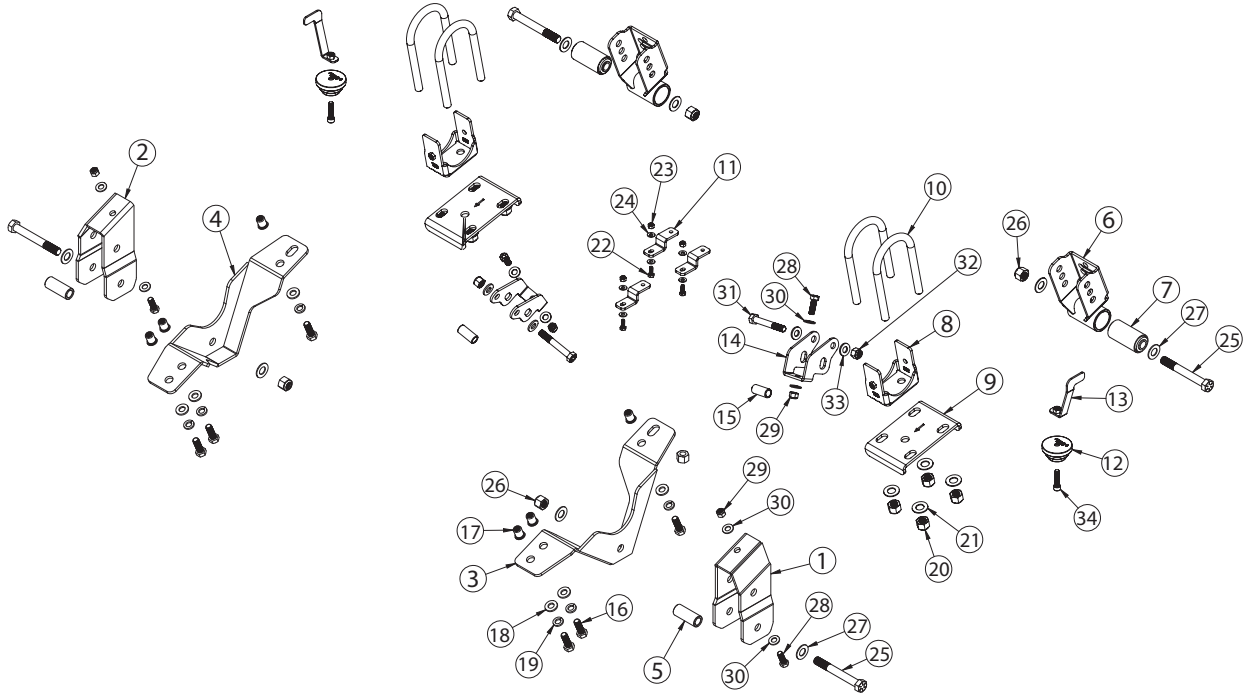

Item #	Part #	Description	QTY
1	90003438	Leaf Spring Front Drop Bracket - Driver	1
2	90003439	Leaf Spring Front Drop Bracket - Passenger	1
3	90003440	Leaf Spring Frame Brace - Driver	1
4	90003441	Leaf Spring Frame Brace - Passenger	1
5	90003442	Leaf Spring Mount Spacer, 656" ID x 1.00" OD x 2.43 Long	2
6	90003443	Rear Shackle	2
7	70015559	Shackle Bushing - installed in shackle	2
8	90003444	Leaf Spring Flip Bracket	4
9	90001366	Leaf Spring Clamp Plate	2
10	99626004	U-Bolt, 3.375"W x 7.00"L x 5/8"-18	4
11	90003445	Differential Harness Relocation Bracket	3
12	70015643	Bump Stop	2
13	90003446	Bump Stop Nut Plate	2
14	90003447	Rear Shock relocation Bracket	2
15	90003474	Sleeve, .558" ID x .75" OD x 1.67 Long	2
	90003448	1/2" Riv-Nut Tool	1
11729511 KIT SHOCKS (Shock are NOT included with 11729512 Kit)			
	986-10-806	6.3" Travel Single Adjustable Shock	2
	815-05-022-KIT	1.7" Shock Eyelet	2
	90001994	Shock Bearing, .625" D - installed in shock	4
	90001995	Internal Snap Ring - installed in shock	8
	90003449	Shock Bearing Spacer - .500" ID x .81" Spaced Length	4
	90003473	Shock Bearing Spacer - 14mm" ID x .588" Spaced Length	4



Hardware Kit #99010215In the box

Item #	Part Number	Description	QTY	QTY	Part Number	Description	QTY
FRAME BRACE				REAR SHACKLE			
16	99501053	1/2-13 x 1 1/2" Hex Bolt	6	25	99621007	5/8-18 x 5" Hex Bolt	2
17	99502024	1/2"-13 Riv-Nut	6	26	99622001	5/8-18 Nylok Nut	2
18	99503014	1/2" SAE Flat Washer	6	27	99623001	5/8" SAE Flat Washer	4
19	99503015	1/2" Split Lock Washer	6	FRONT LEAF MOUNT			
U-BOLT				28	99431021	7/16-14 X 1 1/4" Hex Bolt	2
20	99622001	5/8-18 Nylok Nut	8	29	99432010	7/16-14 Nylok Nut	2
21	99623001	5/8" SAE Flat Washer	8	30	99433005	7/16 SAE Flat Washer	4
DIFF HARNESS BRACKETS				REAR SHOCK MOUNT			
22	99253003	1/4-20 x 3/4" Hex Bolt	3	28	99431021	7/16-14 X 1 1/4" Hex Bolt	2
23	99252003	1/4-20 Nylok Nut	3	29	99432010	7/16-14 Nylok Nut	2
24	99253008	1/4" SAE Flat Washer	6	30	99433005	7/16 SAE Flat Washer	4
FRONT LEAF EYE				31	99501005	1/2-13 x 3 1/2" Hex Bolt	2
25	99621007	5/8-18 X 5" Hex Bolt	2	32	99502009	1/2-13 Nylok Nut	2
26	99622001	5/8-18 Nylok Nut	2	33	99503014	1/2" SAE Flat Washer	4
27	99623001	5/8" SAE Flat Washer	4	BUMP STOP			
	90002263	Red Loctite	1	34	99371019	3/8-16 x 1 1/2" Socket Head	2

Getting Started.....

THIS KIT CAN BE SETUP TO LOWER THE REAR OF YOUR TRUCK 3 DIFFERENT HEIGHTS. IT CAN BE SET TO LOWER THE REAR OF THE TRUCK 3 1/2", 4" OR 4 1/2". THIS HEIGHT ADJUSTMENT IS BUILT INTO THE REAR SPRING SHACKLE. BEFORE YOU START THE INSTALL, MEASURE THE HEIGHT OF YOUR TRUCK TO HELP DETERMINE HOW YOU WANT IT TO SIT. THE RIDETECH FRONT KIT HAS SOME ADJUSTMENT TOO. THE FRONT KIT WILL LOWER THE TRUCK 2". YOUR TIRE HEIGHT WILL PLAY A FACTOR ON HOW LOW YOU CAN SET THE FRONT SUSPENSION.

1. Raise the vehicle to a safe and comfortable working height and support it by the frame. You will need to be able to move the rear differential up and down. Use a jack under the rear axle to raise and lower it during the install.
2. Jack up the rear end slightly to remove the tension from the rear shocks. Remove the shock absorbers. Retain the OEM hardware. For proper function, they should be replaced with the Ridetech HQ Series shocks 11729510. Shocks are included with Kit # 11729511. Shocks are NOT included with Kit # 11729512.

Disassembly

3. Lower the jack to relieve the tension on the rear springs, but keep the jack touching the rear axle.
4. Remove the u-bolts and axle clamps to disengage the axle from the leaf springs.
5. Lower the axle to get clearance on the leaf springs, but **DO NOT** strain the brake lines.
6. The leaf springs will need to be removed to install the rear lowering kit. Retain the hardware for reassembly. We suggest marking the leaf springs driver and passenger. This can be done with a piece of masking tape and a marker. The leaf springs are heavy and may require assistance to remove and reinstall them. Repeat Steps 4 - 6 on the 2nd leaf spring.



Disassembly



7. Unbolt the brake line bracket from the mount that is below the leaf spring on each side of the axle. Retain the hardware for reassembly.



8. The OEM bump stop mount will need to be cut off the frame. We do this by cutting the weld with a cut off wheel on a die-grinder. Cut in the center of the weld without going too deep. Cutting too deep will cut into the frame.

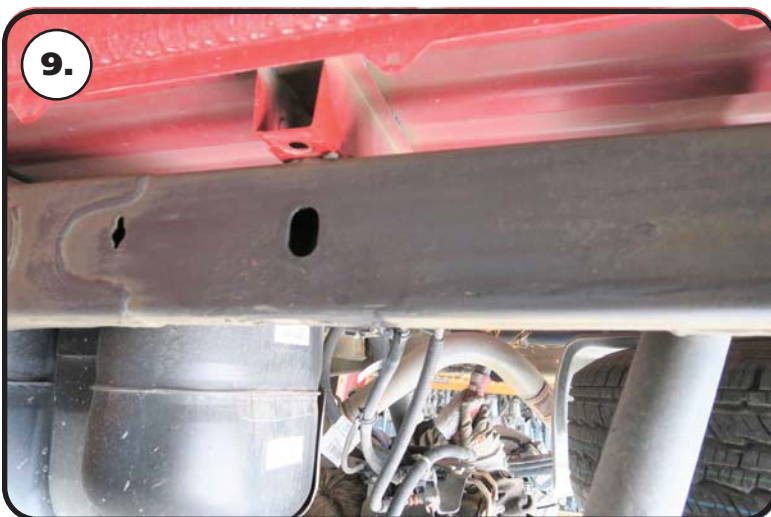

9. We recommend grinding the remaining weld down until it is smooth. Paint the exposed metal to keep it from rusting.



Disassembly



10. The leaf spring locating pin needs to be flipped over. Currently, the nut for the pin is on the top side of the leaf spring pack. The nut will need to be on the bottom side for proper location of the flip bracket. The u-bolt locating plate will need to be removed and discarded. To remove the pin and u-bolt locator, clamp the leaf springs together in front of and behind the u-bolt locator. With the leaf spring clamped, remove the nut from the locating pin. Next, remove the u-bolt locator and discard it.



11. Remove the locating pin from the leaf spring pack. Reinstall the locating pin from the TOP side. Reinstall the nut on the BOTTOM side and tighten. With the nut tight, remove the clamps. Repeat on the second spring.



12. Next, remove the OEM shackle from the leaf spring. **Note the orientation of the OEM bolt, it will be reinstalled in the same orientation with the new shackle.** Retain the OEM hardware for reassembly.



Brake Line Bracket Installation



13. Unbolt the brake line bracket from the top of the differential. This will help provide enough slack in the lines to be able to flip the leaf springs on the bottom side of the axle. Retain the hardware, this bracket will be reinstalled later.



14. The kit includes 3 identical brackets that will be used to relocate the differential bracket down and forward. Attach the brackets to the differential mount at the (3) locations the brake line bracket was bolted to. The relocation bracket needs to be installed with the slotted hole forward. Align the holes of each bracket with the mounting holes of the differential bracket. Insert an OEM bolt in each aligned hole. Leave these bolts loose until the mount is attached.



15. Install a 1/4" flat washer on each of (3) 1/4"-20 x 3/4" bolts. Align the brake line bracket with the relocation brackets and insert a 1/4" bolt/washer in each mounting hole. Install a 1/4" flat washer and 1/4" nylok nut on each bolt. Torque the hardware to 92 in-lbs.



Shackle & Front Leaf Spring Bracket Installation



16. Attach the new shackle to the leaf spring using the OEM hardware. The closed side of the shackle needs to be on the same side as the top of the leaf spring. When installing the hardware, make sure the nut will be on the outside of the truck.



17. Install the OEM nut on the shackle bolt. Again, make sure the nut will be on the outer side of the leaf spring. The hardware will be left loose until the truck is on the ground. Repeat on the second spring.

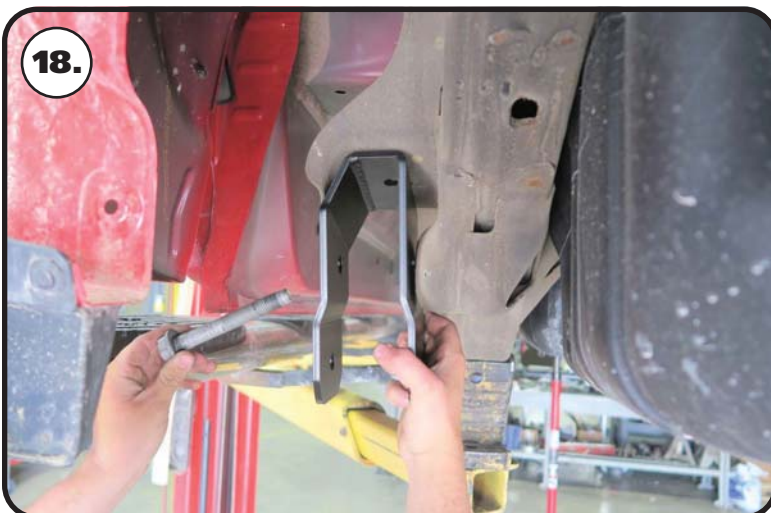

18. The kit includes a front leaf spring relocation bracket. These brackets are side specific and will only fit correctly when installed on the correct side. The angle goes to the outside of the frame. Align the bracket with the OEM leaf spring hole. The kit includes a 2.43" long spacer to be installed in place of the leaf spring on the OEM leaf spring bolt. This keeps the leaf spring bracket installed. IF YOU ARE INSTALLING THE OPTIONAL TRACTION BARS, THE FRONT OF THE TRACTION BAR WILL BE INSTALLED ON THE OEM LEAF SPRING HOLE, see **Step 19**.



Front Leaf Spring Bracket Installation



19. Image 19 shows the leaf spring relocation bracket with the optional traction bars. Refer to the Traction Bar instructions for proper hardware and installation. If you are not installing traction bars, a 2.43" long spacer (90003442) will be installed in its place. With the leaf spring bracket and spacer/traction bar aligned, install the OEM front leaf spring bolt



20. Install a 7/16" flat washer on a 7/16"-14 x 1 1/4" bolt. Insert it in the top hole of the bracket and OEM leaf spring mount. Install a 7/16" flat washer and 7/16"-14 nylok nut on the threads of the bolt and torque to 70 ft-lbs.

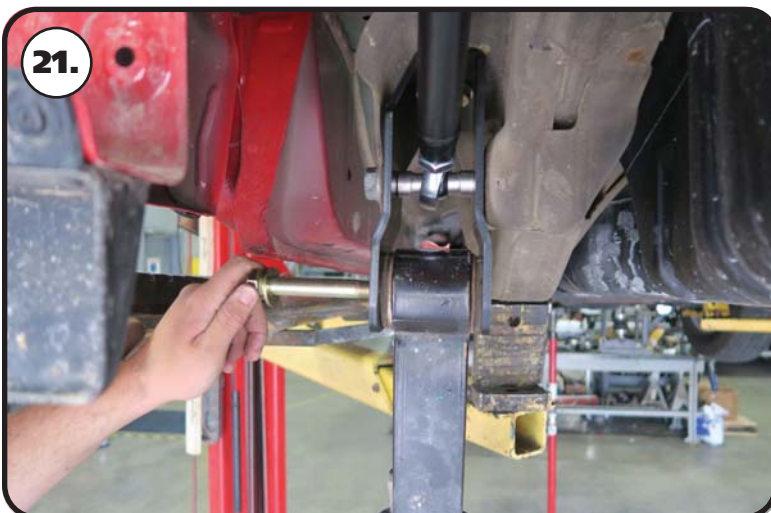

21. Insert the front of the leaf spring in the new bracket. Install a 5/8" flat washer on a 5/8"-18 x 5" bolt. With the mounting holes aligned with the inner sleeve of the leaf spring, insert the bolt/washer. **DO NOT INSTALL THE WASHER AND NUT AT THIS TIME.**



Front Leaf Spring Bracket Installation



22. The kit includes a frame brace for the front leaf spring mount. These mounts are side specific. The mount will align with the frame with the slot in the top flange to the rear of the truck. The side hole will slip over the leaf spring bolt.



23. Mark the 3 holes of the upper flange. There's 2 holes in the front, 1 to the rear. Remove the bracket to allow access to the bottom of the frame rail.



24. Center punch the marked holes. Use a smaller drill bit to drill a pilot hole at each marked location.



Front Leaf Spring Bracket Installation



25.

25. Drill the 3 holes out to 11/16".



26.

26. Install the Rivnuts in the bottom of the frame rail. **Refer to the Rivnut installation instructions on PAGE 11 for proper Rivnut installation.** Image 26 illustrates a Rivnut being installed on the installation tool.



27.

27. Install all (3) Rivnuts in the frame rails.



Rivnut® Installation & Specs

1. Drill Hole in Frame to 11/16" using an 11/16" drill bit or stepped Unibit keeping the Drill square with the metal.
2. We recommend installing (2) 1/2" Flat Washers between the bolt head and the lower anvil of the installation tool. Thread a Rivnut® onto the supplied Tool. Thread the Rivnut all the way onto the Tool until it stops.
3. Insert the Tool and Rivnut® into the drilled hole 90° to the Frame Rail.
4. The Tool requires (2) 3/4" Wrenches to use. A Ratchet can be used on the top of the Tool.

KEEP THE TOOL AND RIVNUT 90° TO THE SURFACE WHILE TIGHTENING

5. Put a 3/4" Wrench on the Lower Hex of the tool. Use a Wrench or Ratchet on the Top hex to Tighten.
6. Hold the Wrench in one position and turn the TOP HEX CLOCKWISE to engage the Rivnut®. Keep Turning the TOP WRENCH until you feel a positive stop and you can't turn the TOP WRENCH anymore.
7. Break the Tool loose by turning the TOP HEX counterclockwise and thread the Tool out of the Rivnut®

THE DATA BELOW ILLUSTRATES THE STRENGTH OF THE RIVNUT®

RIVNUT® Fastener Engineering Data

Upset Load (lbs.)		
RIVNUT® Size	Steel	
	Min. Grip	Max. Grip
1/2-13	5800	6300

Fig. 1

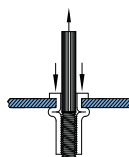

Ultimate thread strength (lbs.)		
RIVNUT® Size	Steel	
	Min. Grip	Max. Grip
1/2-13	17250	14500

Fig. 2

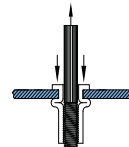

Ultimate tensile strength (lbs.)	
RIVNUT® Size	Steel
1/2-13	4900

Fig. 3

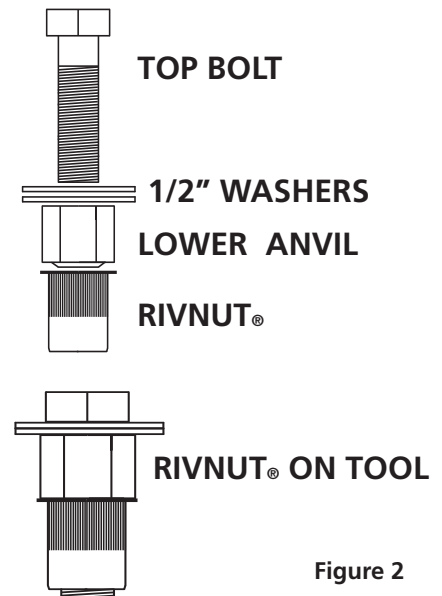
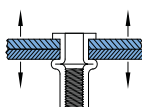

Figure 2

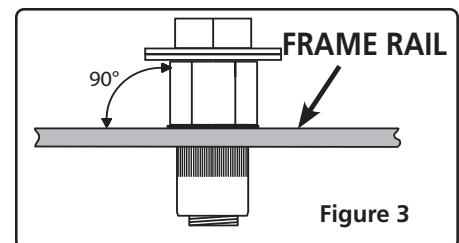

Figure 3

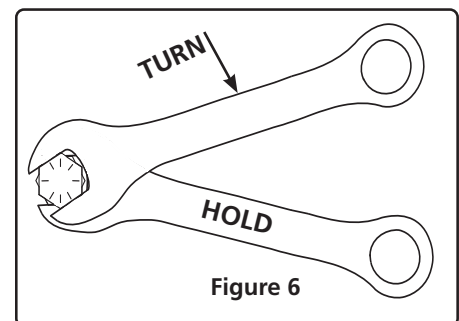

Figure 6



Front Leaf Spring Bracket Installation



28. Reinstall the frame brace bracket. Install a 5/8" flat washer and 5/8"-18 nylok nut on the leaf spring bolt. You can snug, but do not completely tight until the truck is on the ground.



29. Install a 1/2" split lock washer & 1/2" SAE flat washer on each of (3) 1/2"-13 x 1 1/2" hex bolts. Insert the bolts/washer through the bracket, threading them into the Rivnuts.



30. Torque the 1/2" hardware to 75 ft-lbs. Again, **DO NOT TIGHTEN THE LEAF SPRING BOLT UNTIL THE TRUCK IS SITTING ON THE GROUND.** Repeat **Steps 17-30** on the other side of the truck.



Shackle & Flip Bracket Installation



31. Raise the rear of the leaf spring up to the factory mount. You may need to jack the rear differential up to get enough clearance on the leaf spring. Install a 5/8" flat washer on a 5/8"-18 x 5" hex bolt. Align the through hole of the shackle bushing with the OEM shackle mounting holes. Insert the 5/8" bolt/washer through the aligned holes.



32. Install a 5/8" flat washer and 5/8"-18 nylok nut on the threads of the bolt. Snug down the hardware, but **DO NOT** tighten until the truck is sitting on the ground.

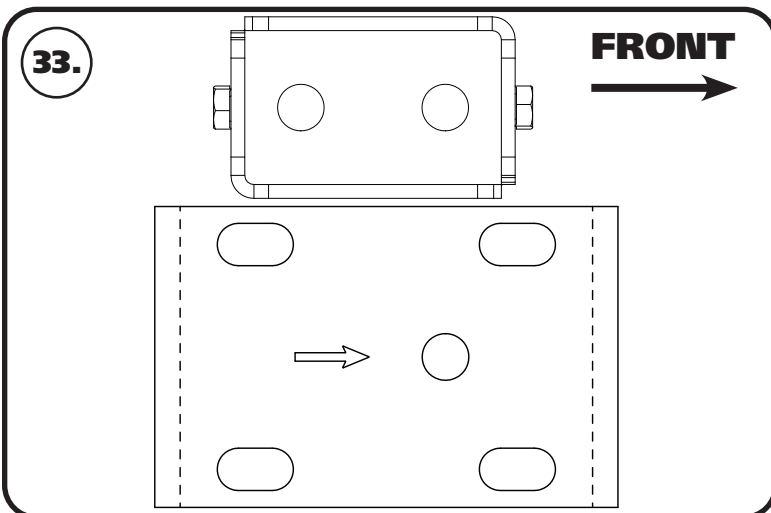

33. The Flip Kit has the locating holes offset to center the wheel in the wheel opening. **Image 33** illustrates a top view of the Flip Bracket and the Leaf Spring Plate. Notice the locating holes are not centered. These brackets are designed to move the axle to the rear of the truck to keep the differential centered in the wheel opening. The **ARROW** in the clamping plate needs to point to the front of the truck. The orientation of the flip bracket is covered in the next step.



Flip Bracket Installation

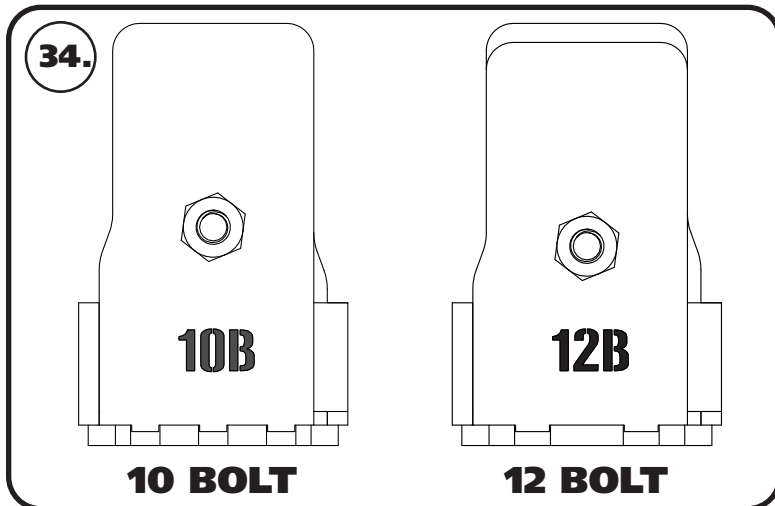

34. These trucks came with either a 10 bolt or 12 bolt differential. You can determine which differential you have by counting the number of bolts that hold the differential cover on. The flip bracket has 10B on one side and 12B on the other side. **THE NUMBER THAT CORRESPONDS WITH THE NUMBER OF BOLTS IN YOUR DIFFERENTIAL COVER NEEDS TO BE POSITIONED TO THE FRONT OF THE TRUCK.**

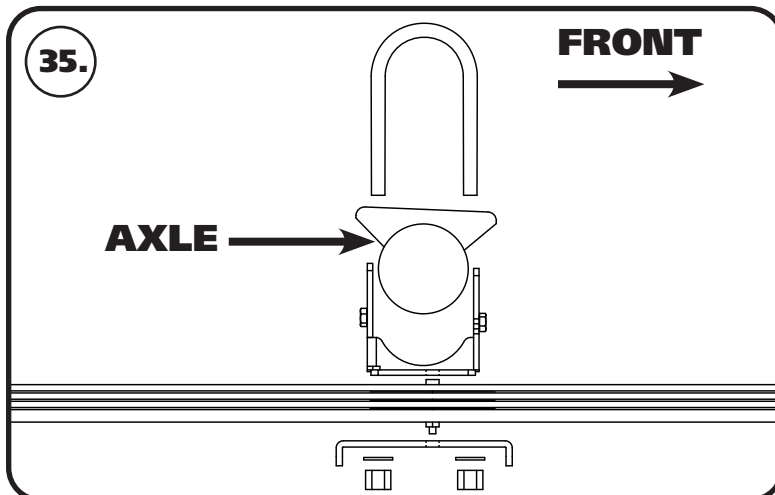

35. Image 35 is an illustration with the parts exploded to assist in the assembly of the flip kit. **IF INSTALLING THE OPTIONAL TRACTION BARS WITH THIS KIT, SEE STEP 36.** If you are NOT installing the traction bar kit, skip to Step 37.

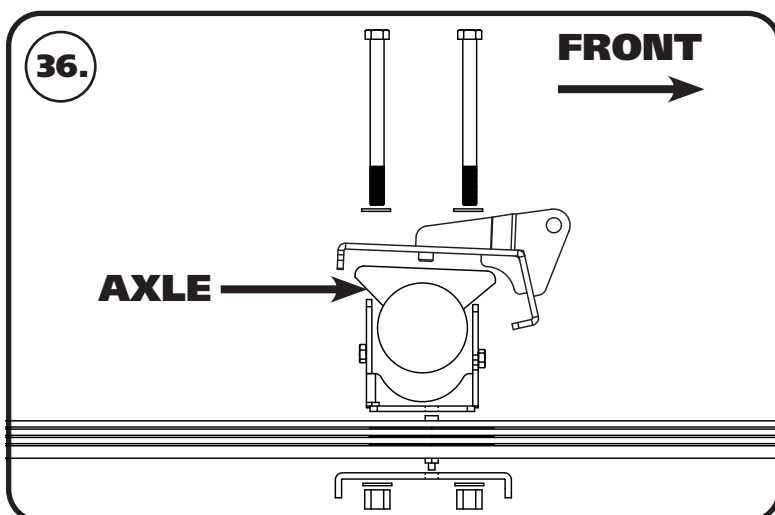

36. OPTIONAL TRACTION BAR AXLE BRACKET ONLY!! The traction bar kit uses an upper axle mount and 5/8"-18 x 7.5" hex bolts instead of using the u-bolts that are supplied in the flip kit. The pivot mount will be to the front of the truck with the locating pin nested into the hole of the OEM leaf spring mount.



Flip Bracket Installation

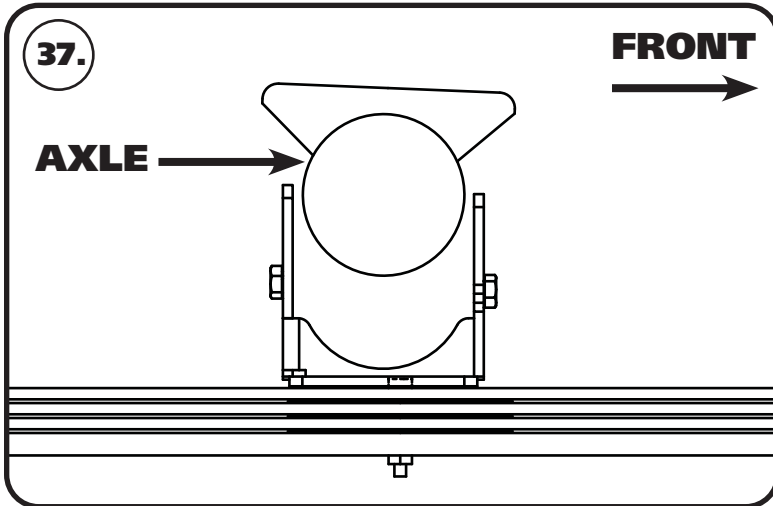

37. Set the Flip Bracket onto the leaf spring with the CENTER HOLE OFFSET TO THE FRONT OF THE TRUCK. **Step 34** will help you determine the orientation of the flip bracket. The locating pin needs to be in the front hole of the flip bracket.

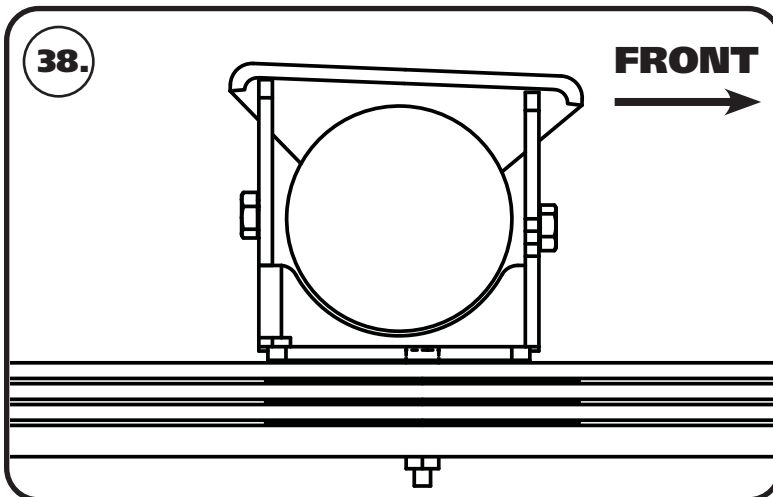

38. Slowly lower the axle into the Flip Bracket making sure the tabs go up into the leaf spring saddle. THE FLIP BRACKET WILL POSITION THE PINION AT THE CORRECT ANGLE.

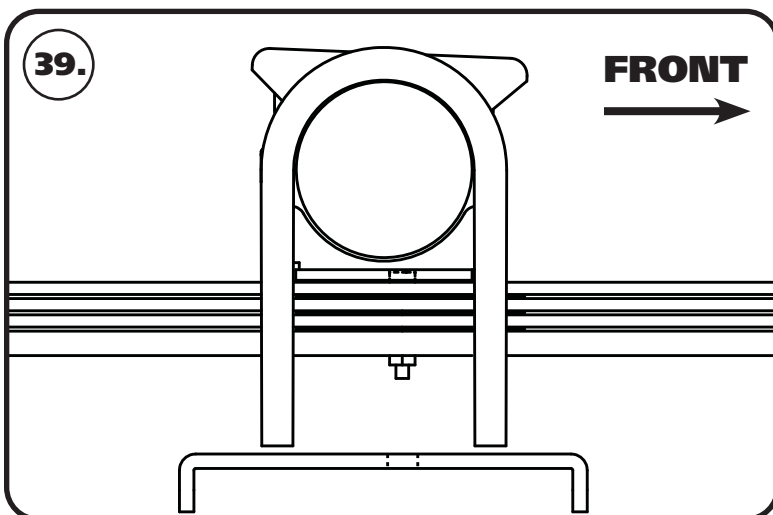

39. Slip the U-Bolts over the axle tube with the threads pointing down.



Flip Bracket Installation

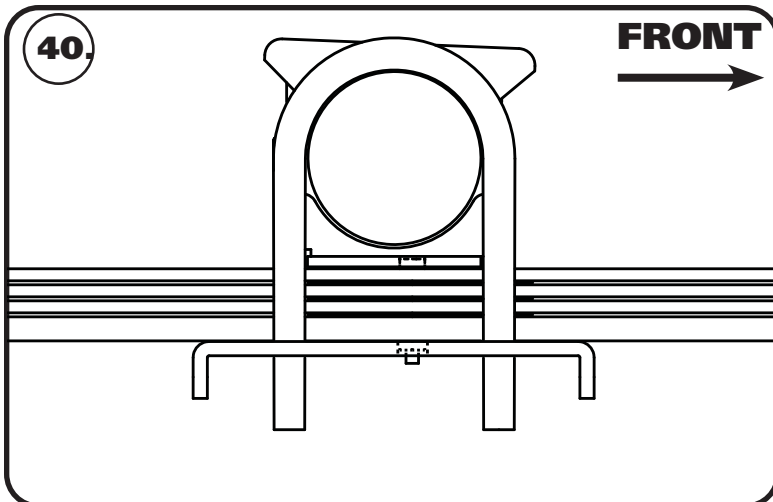

40. Slip the Leaf Spring Bracket up onto the U-Bolts WITH THE OFFSET HOLE FORWARD. THE ARROW ON THE BRACKET SHOULD POINT TO THE FRONT OF THE TRUCK.

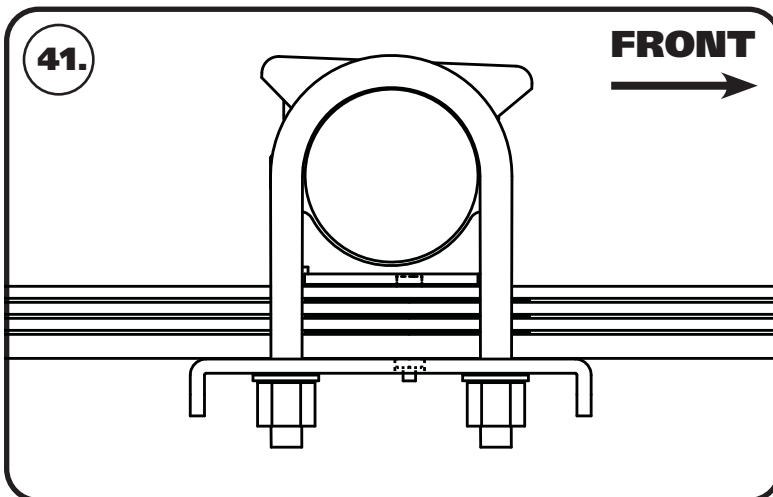

41. Hold the Leaf Spring Bracket in place and install a 5/8" Flat Washer & 5/8"-18 Nylok Nut on the threads of the u-bolts. Snug the nuts down evenly and tighten them in a criss-cross fashion to 130 ftlbs.



42. Attach the OEM brake line bracket to the rear of the flip bracket using the OEM hardware. Torque to 18 ft-lbs.



Bump Stop & Shock Bracket Installation



43. Insert the bump stop nut plate in the side hole of the frame that is near the OEM bump stop location. The tab of the nut plate will assist you in holding it in place.



44. Insert a 3/8"-16 x 1 1/2" socket head cap screw in the center of the bumpstop. The large diameter of the bump stop will go against the bottom of the frame rail. Using a hex wrench inserted into the socket head cap screw, align the bump stop with the hole in the bottom of the frame and the nut plate. Thread the bolt into the nut plate. Torque to 35 in-lbs.



45. Steps 45-47 cover installation of the lower shock relocation bracket. This bracket helps correct the shock angle at the new lower ride height. Slip the bracket over the OEM lower shock mount. Align the hole of the relocation bracket with the OEM shock mounting hole. The bracket should sit against the front of the OEM shock mount. Insert the 1.670" long spacer in the OEM shock mount, aligning it with the OEM shock mounting hole. Insert the OEM hardware in the OEM shock mounting location. Install the OEM nut but do not tighten at this time.



Shock Relocation Bracket Installation



46 Use the shock relocation bracket as a template to drill a 7/16" hole in the OEM shock mount.



47. Install a 7/16" flat washer on a 7/16"-14 x 1 1/4" hex bolt. Insert the bolt through the relocation bracket and into the previously drilled hole. Install a 7/16" flat washer and 7/16"-14 nylok nut on the bolt. Torque the 7/16" hardware to 70 ft-lbs. Torque the OEM shock bolt to 104 ft-lbs. Repeat **Steps 45-48** on the 2nd shock mount.

11709512 KIT DOES NOT INCLUDE SHOCKS!!



48. Steps 48-51 cover the shock installation. The kit includes bearing spacers for the top and bottom shock mounting. The top bolt uses the larger ID spacers. Insert the SMALL end of the bearing spacers into the shock bearings of the eyelet. Insert the eyelet of the shock into the top upper mount and reinstall the OEM shock bolt.



Shock Installation 11729511 KIT ONLY



49. Torque the top shock bolt to 85 ft-lbs.



50. Insert the SMALL end of the bearing spacers into the shock bearings of the shock body. Insert the shock body into the relocation bracket.



51. Install a 1/2" flat washer on a 1/2"-13 x 3 1/2" hex bolt. Insert the bolt/washer in the relocation bracket/shock. Install a 1/2" flat washer and 1/2"-13 nylok nut on the threads of the bolt. Torque to 85 ft-lbs. Repeat **Steps 48-51** on the 2nd shock.



Final Tightening

52. Set the truck on the ground. Torque the leaf spring and shackle hardware to 130 ftlbs and the upper control arm mounting bolts to 140 ft-lbs. Grease the ball joints.

53. Any time you change suspension components, the front end alignment will need to be checked. **Any time you replace front suspension components, you should have the alignment checked.**

Suggested Alignment Specs:

Camber:	0 to -.75 degrees
Caster:	+5.5 to + 7.5 degrees
Toe:	1/16" to 1/8" toe in

Shock Adjustment

54. We recommend starting with the shock adjustment at 12 clicks out from full stiff. Adjust the shock full stiff (clockwise) and count the clicks as you adjust the knob counter clockwise.

Shock Adjustment 101- Single Adjustable

Rebound Adjustment:

How to adjust your new shocks.

The rebound adjustment knob is located on the top of the shock absorber protruding from the eyelet.

You must first begin at the ZERO setting, then set the shock to a medium setting of 12.



-Begin with the shocks adjusted to the ZERO rebound position (full stiff). Do this by rotating the rebound adjuster knob clockwise until it stops.

-Now turn the rebound adjuster knob counter clock wise 12 clicks. This sets the shock at 12. (settings 21-24 are typically too soft for street use).

Take the vehicle for a test drive.



-if you are satisfied with the ride quality, do not do anything, you are set!

-if the ride quality is too soft increase the damping effect by rotating the rebound knob clock wise 3 clicks.

Take the vehicle for another test drive.



-if the vehicle is too soft increase the damping effect by rotating the rebound knob clock wise 3 additional clicks.

-If the vehicle is too stiff rotate the rebound adjustment knob counter clock wise 2 clicks and you are set!

Take the vehicle for another test drive and repeat the above steps until the ride quality is satisfactory.

Note:

One end of the vehicle will likely reach the desired setting before the other end. If this happens stop adjusting the satisfied end and keep adjusting the unsatisfied end until the overall ride quality is satisfactory.