

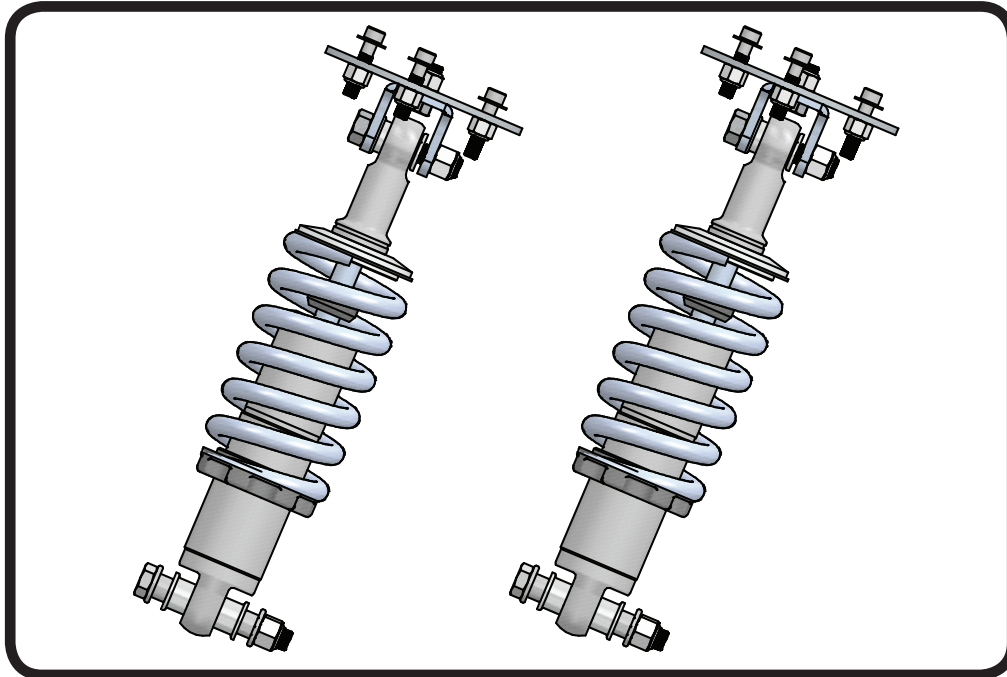

Part # 12263110 - Crown Vic HQ Series Front CoilOvers

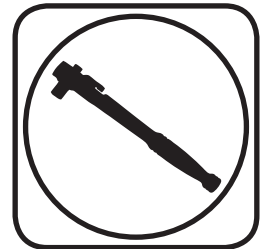

Recommended Tools



Crown Vic HQ Series Front CoilOvers Installation Instructions

Table of contents

Page 2.....	Included components
Page 3.....	Getting Started and CoilOver Assembly
Page 4.....	Upper Mount Assembly and Installation
Page 5.....	CoilOver Installation
Page 6.....	CoilSpring Adjusting
Page 7.....	Shock Adjustment





Major ComponentsIn the box

Item #	Part #	Description	QTY
1	24139999	3.6" Stroke HQ Series Shock	2
2	90002025	Upper Shock Eyelet	2
3	90002222(kit)	Coil Spring Mounting Kit	2
4	59080650	8" 650lb CoilSpring	2
5	70010828	Delrin Spring Washer	4
6	90002189	Upper Mounting Plate	2
7	70012120	Upper Shock Bracket (Bolts to 90002189)	2
8	90002040	Upper Shock Bearing Spacers	4
9	90002062	Lower Shock Bearing Spacers	4
10	90002188	Lower Control Arm T-Bushing	4
11	99311003	5/16"-18 x 1 1/2" Hex Bolt	6
12	99312003	5/16"-18 Nylok Nut	6
13	99313002	5/16" SAE Flatwasher	6
14	99431001	7/16"-14 x 1" Hex Bolt	2
15	99432001	7/16"-14 Nylok Nut	2
16	99501011	1/2"-20 x 2 1/2" Hex Bolt	2
17	99502002	1/2"-20 Nylok Nut	4
18	99501015	1/2"-20 x 3 3/4" Hex Bolt	2

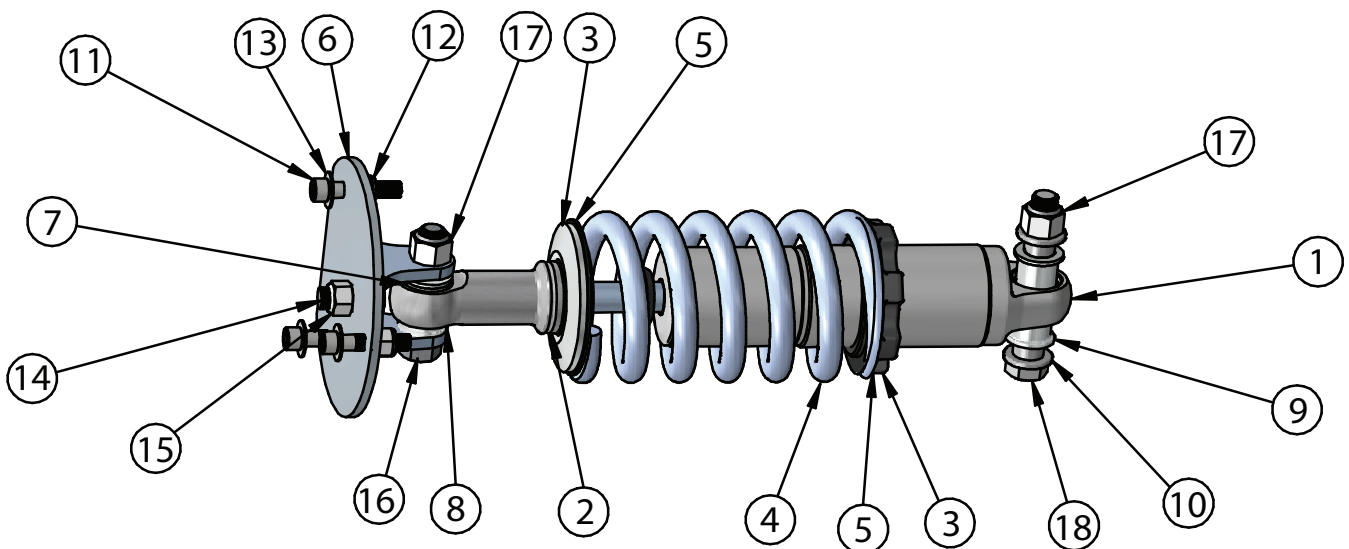



Getting Started.....

Congratulations on your purchase of the Ridetech Crown Vic Crossmember CoilOver System. This system has been designed to give your vehicle excellent handling along with a lifetime of enjoyment. The CoilOver System provides flexibility that can not be achieved with traditional coil spring setups. The CoilOver System will give you the flexibility of adjusting your ride height along with numerous spring options to dial in your ride quality to your personal preference.

This CoilOver System is Designed to replace the factory Shock and Coil Springs.

1. The front OEM Shocks and CoilSpring Assembly will need to be removed from the crossmember. Refer to the factory Service Manual if you need assistance.

CoilOver Assembly



First using the supplied lower adjuster nut(90002222) thread the nut onto the shock from the top side as seen in figure 1

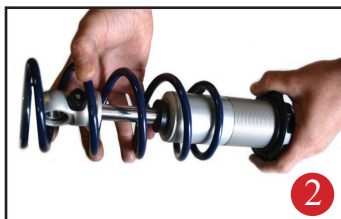

Next install delrin washers then coil spring over the top of the shock as seen in figure 2



Before the upper spring mount can be installed screw the adjuster knob on the upper eye mount to the firmest setting (clockwise) as seen in figure 3. and remove knob.



Slide the Derlin washer over the spring, Next slide the upper spring mount (90002222) over eyelet as seen in figure 4.



Install upper spring mount retainer clip (90002057) into the groove on the upper eyelet as seen in figure 5. Then reinstall adjuster to complete assembly.



Upper Mount Assembly and Installation



2. Both sides of the suspension use the same Upper Mounting Plate. Both Upper Mounting Plates and Shock Mounts are assembly identically to each other. Figure "2" shows the bottom side of the Mounting Plate.



3. Using the 7/16-14" x 1" Hex Bolt and 7/16"-14 Nylok Nut bolt the Upper Shock Mount to the Upper Mounting Plate. The 7/16" Bolt needs to be installed with the Hex Head of the bolt in the Shock Mount. The shock mount needs to be clocked on the mounting plate. The edge of the Shock Mount needs to be positioned parallel with the edge of the Mounting Plate. Tighten the 7/16" Bolt and nut keeping the shock mount clocked correctly.



4. Install the upper mount into the cross-member using (3) 5/16" x 1 1/2" Hex Bolts, (3) 5/16" SAE Flatwashers, & (3) 5/16" Nylok Nuts. Position the Straight edge of the Mount facing the Engine Compartment. Tighten the mounting hardware.



CoilOver Installation

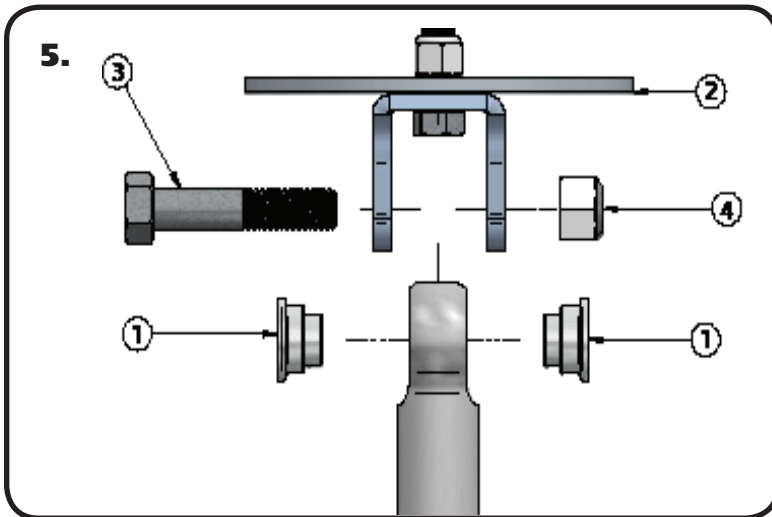

5. With the CoilOver assembled (**Refer to Page 3 for CoilOver assembly instructions**) insert the **NARROW** upper spacers(1) into the upper shock bearings. Install the **WIDE** spacers into the Lower Shock Bearing. With the spacers installed insert the CoilOver assembly into the upper shock mount(2). Align the holes in the bracket with the hole in the Shock spacers and insert the 1/2 x 2 1/2" Bolt(3) and secure with the 1/2" Nylok Nut(4).



6. Insert the supplied T-Bushings into the OEM Control Arm. The T-bushings are installed on the outside of the OEM Control Arm.



7. With the **WIDE** spacers installed in the lower CoilOver Bearing, insert the CoilOver into the Lower Control Arm. Align the hole in the CoilOver with the hole in the T-bushing. Insert the 1/2" x 3 3/4" Hex Bolt into the mounting hole in Lower Control Arm. Install a 1/2" Nylok Nut onto the Bolt and tighten.



CoilSpring Adjusting

Ride Height

We have designed most cars to have a ride height of about 1 1/2" lower than factory. To achieve the best ride quality & handling, the shock absorber needs to be at 40-60% overall travel when the car is at ride height. This will ensure that the shock will not bottom out or top out over even the largest bumps. Measuring the shock can be difficult, especially on some front suspensions. Measuring overall wheel travel is just as effective and can be much easier. Most cars will have 4-6" of overall wheel travel. One easy way to determine where you are at in wheel travel is to take a measurement from the fender lip (center of the wheel) to the ground. Then lift the car by the frame until the wheel is just touching the ground, re-measure. This will indicate how far you are from full extension of the shock. A minimum of 1.5" of extension travel (at the wheel) is needed to ensure that the shock does not top out. If you are more than 3" from full extension of the shock then you are in danger of bottoming out the shock absorber.

Adjusting Spring Height

When assembling the CoilOver, screw the spring retainer tight up to the spring (0 preload). After entire weight of car is on the wheels, jounce the suspension and roll the car forward and backward to alleviate suspension bind.

- If the car is too high w/ 0 preload then a smaller rate spring is required. Although threading the spring retainer down would lower the car, this could allow the spring to fall out of its seat when lifting the car by the frame.
- If the car is too low w/ 0 preload, then preload can then be added by threading the spring retainer up to achieve ride height. On 2.6" - 4" stroke shocks, up to 1.5" of preload is acceptable. On 5-7" stroke shocks, up to 2.5" of preload is acceptable. If more preload is needed to achieve ride height a stiffer spring rate is required. Too much preload may lead to coil bind, causing ride quality to suffer.



Shock Adjustment

Shock adjustment 101- Single Adjustable

Rebound Adjustment:

How to adjust your new shocks.

The rebound adjustment knob is located on the top of the shock absorber protruding from the eyelet.

You must first begin at the ZERO setting, then set the shock to a soft setting of 20.



-Begin with the shocks adjusted to the ZERO rebound position (full stiff). Do this by rotating the rebound adjuster knob clockwise until it stops.



-Now turn the rebound adjuster knob counter clock wise 20 clicks. This sets the shock at 20. (settings 21-24 are typically too soft for street use).

Take the vehicle for a test drive.



-if you are satisfied with the ride quality, do not do anything, you are set!

-if the ride quality is too soft increase the damping effect by rotating the rebound knob clock wise 3 clicks. **CONTINUE ON NEXT PAGE.**

Take the vehicle for another test drive.



-if the vehicle is too soft increase the damping effect by rotating the rebound knob clock wise 3 additional clicks.



-If the vehicle is too stiff rotate the rebound adjustment knob counter clock wise 2 clicks and you are set!

Take the vehicle for another test drive and repeat the above steps until the ride quality is satisfactory.

Note:

One end of the vehicle will likely reach the desired setting before the other end. If this happens stop adjusting the satisfied end and keep adjusting the unsatisfied end until the overall ride quality is satisfactory.

STILL HAVE QUESTIONS?

Tech line hours

Monday - Friday

8AM - 6PM (EST) 812-482-2932