



CAT BACK EXHAUST SYSTEM PART NO. 50102



Fits: 2019-Up Chevrolet Silverado 1500
: 2019-Up GMC Sierra 1500

Engine Size: 6.2L

Cab Size: Double Cab / Crew Cab with Dual Exhaust



ALLOW VEHICLE TO COOL DOWN BEFORE WORKING ON ANY ENGINE / EXHAUST COMPONENTS.



REMOVE CONTENTS FROM BOX. VERIFY ALL PARTS ARE PRESENT.



READ INSTALLATION INSTRUCTIONS COMPLETELY BEFORE BEGINNING REMOVAL AND INSTALLATION



LIMITED LIFETIME WARRANTY



60-120 min



Cutting May be Required



PPE Kit Recommended



support@trailfx.com



1 866 638 4870

REMOVAL:

1. Allow plenty of time for your vehicle to cool down prior to starting. Exhaust systems reach high temperatures and may cause serious burns. Always wear appropriate safety equipment including goggles and gloves.
2. Read instructions prior to installation. Use a penetrating lubricant and spray the exhaust clamp nuts and all the isolation rubber mounts before removal and re-installation.
3. For easier installation, lay out the exhaust system according to the diagram.
4. Use a vehicle hoist to raise vehicle to proper working height. If a vehicle hoist is not available, raise the vehicle and securely support using jack stands. Use of a jack or stand to support the muffler when removing or installing is recommended. (IMAGE 1)
5. If vehicle is equipped with back up sensors, remove screws from driver and passenger side back up sensor brackets. These are located in the rear bumper towards each corner. (IMAGE 2)
6. Unplug driver and passenger sensor wire and remove brackets from vehicle. Retain screws and brackets for re-installation later.

**REMOVAL CONTINUED:**

7. Remove screws from driver and passenger side exhaust bezels and remove bezels from bumper. (IMAGE 3)
8. Remove spare tire and spare tire heat shield from the vehicle. Set aside for re-installation later. (IMAGE 4)
9. Un-bolt the drivers side tailpipe flange and remove the drivers side OEM rubber hanger from frame. Remove passenger side OEM rubber hanger from frame. Retain OEM rubber hangers and bolts for re-installation later. (IMAGE 5)
10. Remove exhaust system hangers from OEM rubber hangers. (IMAGE 6)
11. Remove inlet pipe from OEM rubber hanger. Loosen factory clamp at the catalytic converter and slowly lower the exhaust system down towards the front of the vehicle. (IMAGE 7)
12. Release tab and remove OEM clamp from the connection to the catalytic converter and slide onto the MaxFlow Xtreme inlet pipe or use new clamp (#10) provided in hardware kit. (IMAGE 8)

**IMAGE 1****IMAGE 2****IMAGE 3****IMAGE 4**

**INSTALLATION:**

1. Install the new inlet pipe #1 at catalytic converter. Insert hanger from inlet pipe into OEM rubber hanger. Loosely tighten clamp for possible later adjustment. (IMAGE 9)
2. If installing exhaust system on a crew cab with a 6.5' bed, extension pipe #2 must be used. Slide extension pipe onto the end of the inlet pipe #1 and use provided clamp to loosely tighten for possible later adjustment. Skip step #2 if your vehicle does not have a 6.5' bed.
3. Slide provided exhaust clamp over the muffler inlet. Slide the inlet of the muffler onto the back of inlet pipe using a stand to support the muffler. Loosely tighten the clamp for possible later adjustments. (IMAGE 10)
4. Slide provided exhaust clamps over the muffler outlets. Position the right tailpipe #5 into position over the rear axle and slide into the right muffler outlet. Insert the hanger from the right tailpipe #5 into the OEM rubber mount on the vehicle. Loosely clamp for possible later adjustments. (IMAGE 11)

**IMAGE 5****IMAGE 6****IMAGE 7****IMAGE 8**

**INSTALLATION CONTINUED:**

5. Slide the left front tailpipe #4 over the rear axle and into the left muffler outlet. Slide provided exhaust clamp over the end of the pipe. Insert the hanger from the left front tailpipe into the OEM rubber mount on the vehicle. Loosely tighten clamps for possible later adjustment.
6. Re-install OEM rubber hangers removed in step 9 above on both the left and right rear of vehicle. Slide exhaust clamp on right rear tailpipe and connect to the right front tailpipe. Slide tailpipe hanger into OEM rubber hanger. Loosely tighten clamps for possible later adjustment.
7. Slide exhaust clamp onto left rear tailpipe and then connect to the left front tailpipe. Slide tailpipe hanger into OEM rubber hanger. Loosely tighten clamps for possible later adjustment.
8. Reinstall back up sensor brackets and screws on both sides of vehicle then plug in wiring (if vehicle came equipped with back-up sensors).
9. Install supplied hanger keepers onto inlet pipe and tailpipes. Hanger keeper are important to keep the system from shifting and allowing a hanger to come free from holder.

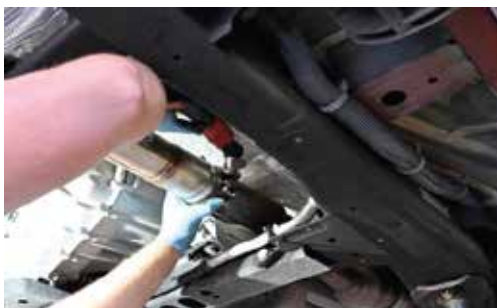
**IMAGE 9****IMAGE 10****IMAGE 11**



INSTALLATION CONTINUED:

10. Install both black powder coat tips #8 on the exits pipes and loosely tighten for possible adjustment later. Adjust the tips and pipes to desired clearances and proper position. (IMAGE 12)
11. Make all necessary adjustments for the pipes and muffler for proper clearances. From front to rear, fully tighten each clamp until connections are secure.

Note: For the most secure installation, installer may weld all slip-fit connections.



IMAGE 12

Please consider these complementary SpeedFX products.

www.Speed-FX.com





PARTS LIST:

Qty	Part Description	Qty	Part Description
1	Inlet Pipe (#1)	1	Hardware Kit****
1	Extension Pipe (#2)	2	3 1/2" Exhaust Clamps (#9)
1	Muffler (#3)	4	2 1/2" Exhaust Clamps (#9)
1	Left Front Tailpipe (#4)	5	1/2" Hanger Keeper
1	Right Front Tailpipe (#5)	1	3 1/2" Inlet Arc Clamp (#10)
1	Left Rear Tailpipe (#6)		
1	Right Rear Tailpipe (#7)		
2	Black Powder Coat Tips (#8)		

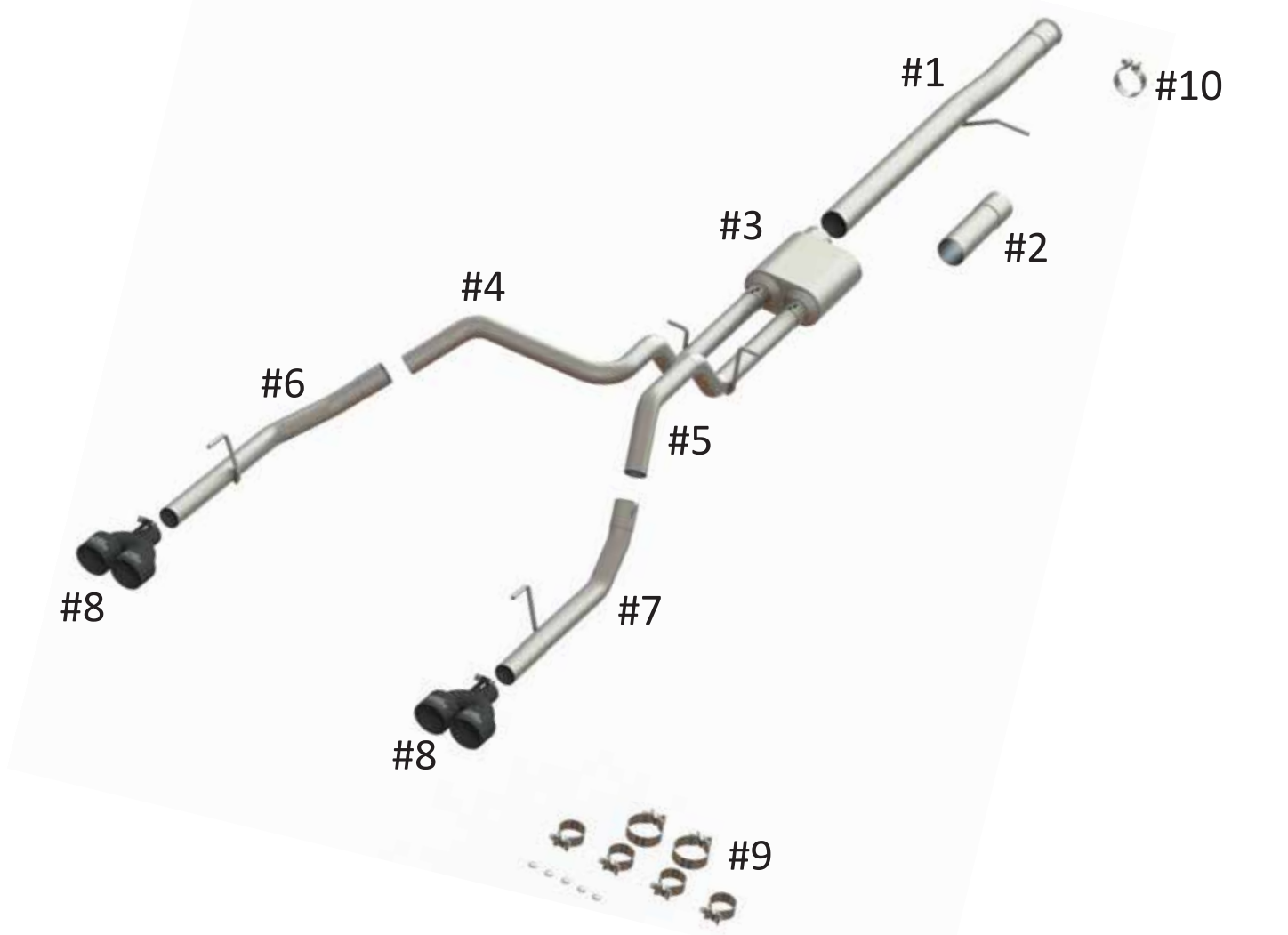

Keystone Automotive Operations (KAO) warrants this product to be free of defects in material and workmanship at the time of purchase by the original retail consumer. KAO disclaims any other warranties, express or implied, including the warranty of fitness for a particular purpose or an intended use. If the product is found to be defective, KAO may replace or repair the product at our option, when the product is returned prepaid, with proof of purchase. Alteration to, improper installation, or misuse of this product voids the warranty. KAO's liability is limited to repair or replacement of products found to be defective, and specifically excludes liability for any incidental or consequential loss or damage.