

**NOTES:**

1. THIS DRAWING DESCRIBES THE FUELAB 555xx SERIES MINI FUEL PRESSURE REGULATOR.
2. FEATURES INCLUDE:
  - ONE -8AN INLET PORT (ON BOTTOM OF REGULATOR)
  - TWO -8AN OUTLET PORTS (ON EITHER SIDE OF REGULATOR)
  - AVAILABLE IN PRESSURE RANGES: "L", "C" AND "T"
  - BILLET ALUMINUM, STAINLESS STEEL CONSTRUCTION WITH FLUOROSILICONE DIAPHRAGM AND SEALS. PLUG AND FITTING ARE MADE OF UNPLATED BRASS OR BRONZE.
3. FUEL COMPATIBILITY INCLUDES:
  - GASOLINE (PUMP OR RACE)
  - METHANOL
  - ETHANOL (INCLUDING E85)
  - DIESEL
4. UNIQUE SERIAL NUMBER DOES NOT CONTAIN DIRECT INFORMATION IN DETERMINING MODEL NUMBER. CONTACT FUELAB FOR DETERMINATION OF MODEL NUMBER BASED ON SERIAL NUMBER.
5. BRACKET, PRESSURE ADJUSTMENT HARDWARE, BRACKET MOUNTING HARDWARE, GAUGE PORT PLUG, BARBED FITTING, 3X -908 PORT O-RINGS AND INSTRUCTIONS INCLUDED, BAGGED SEPARATELY FROM REGULATOR.
6. SEE TABLES BELOW FOR DETERMINATION OF DESIRED MODEL NUMBER.
7. RATED FLOW CAPACITY IS A FUNCTION OF PRESSURE SETTING AS WELL AS RETURN LINE SIZE AND CONFIGURATION, THEREFORE FLOW CAPACITY MAY BE HIGHER OR LOWER, BUT REPRESENTS TYPICAL CAPACITY. REGULATION SLOPE REFERS TO CHANGES IN FUEL PRESSURE AS A FUNCTION OF CHANGES IN FLOW RATE. AS THE AMOUNT OF FUEL RUNNING THROUGH THE REGULATOR REDUCES, THE REGULATED PRESSURE WILL LOWER, SPECIFIED BY THE REGULATION SLOPE.
8. FOR TYPICAL NATURALLY ASPIRATED CARBURETED APPLICATIONS, PRESSURE REFERENCE PORT IS VENTED TO ATMOSPHERE USING SUPPLIED SINTERED BRONZE FILTER. ALTERNATE PLUMBING METHODS CAN BE EMPLOYED. CHANGES IN AIR PRESSURE AT THIS PORT WILL RESULT IN A CHANGE IN FUEL PRESSURE AT A RATIO OF 1:1.

**MODEL NUMBER SCHEME:**

- 55501 - c**  
 c = COLOR CODE  
 STANDARD CARBURETED ("C" PRESSURE RANGE) FUEL PRESSURE REGULATOR
- 55502 - c**  
 c = COLOR CODE  
 LOW PRESSURE CARBURETED ("L" PRESSURE RANGE) FUEL PRESSURE REGULATOR
- 55503 - c**  
 c = COLOR CODE  
 "T" PRESSURE RANGE FUEL PRESSURE REGULATOR

**PERFORMANCE SPECIFICATIONS**

MODEL	APPROX. PRESSURE RANGE	APPROX. FLOW CAPACITY	REGULATION SLOPE
55501-c	4-12 PSID (0.28 - 0.82 BAR)	1.67 GPM (380 LPH)	0.8 PSI/GPM
55502-c	1-3 PSID (0.1 - 0.22 BAR)	1.25 GPM (285 LPH)	0.7 PSI/GPM
55503-c	10-25 PSID (0.7 - 1.7 BAR)	2.5 GPM (570 LPH)	0.9 PSI/GPM

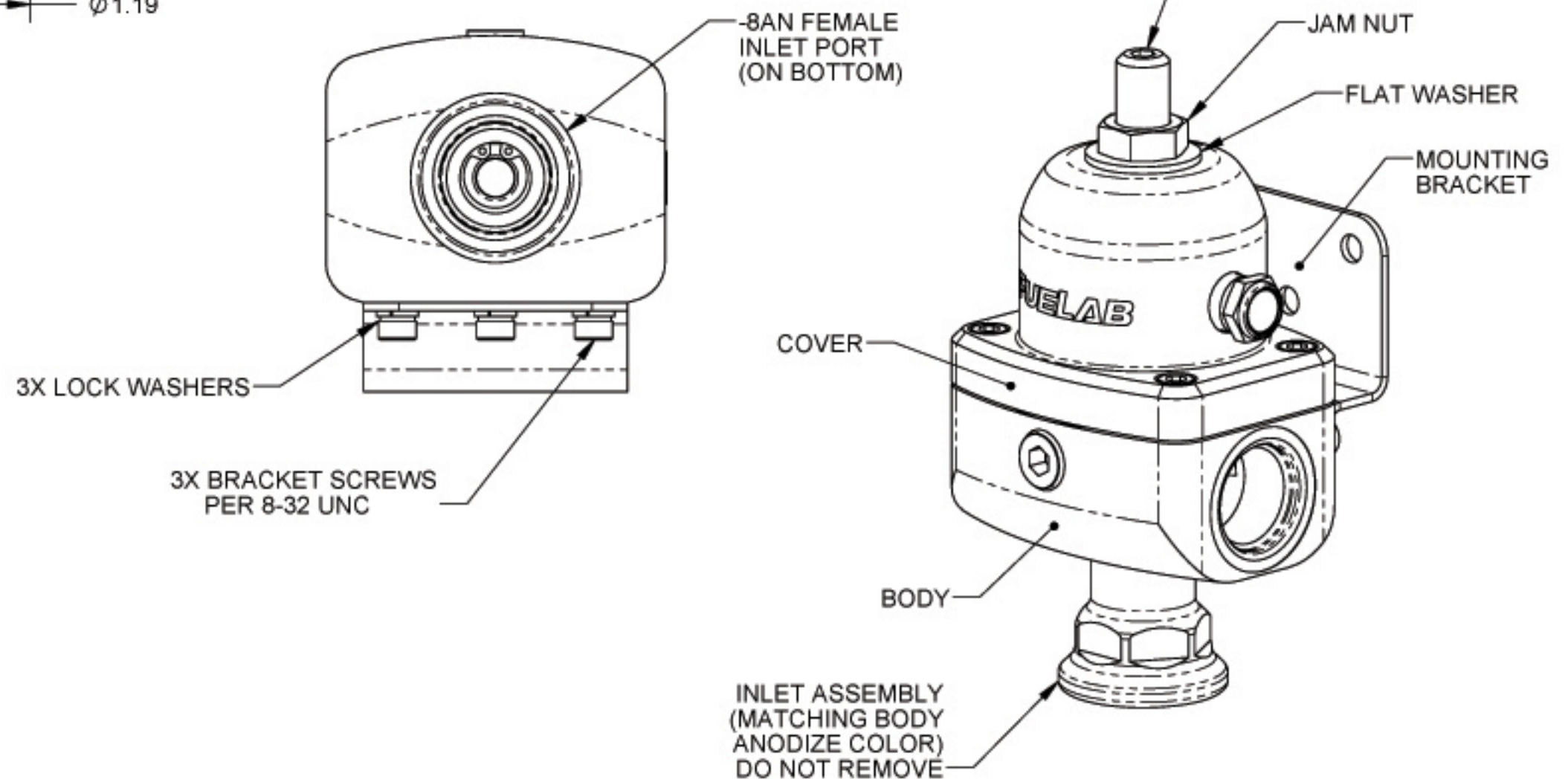
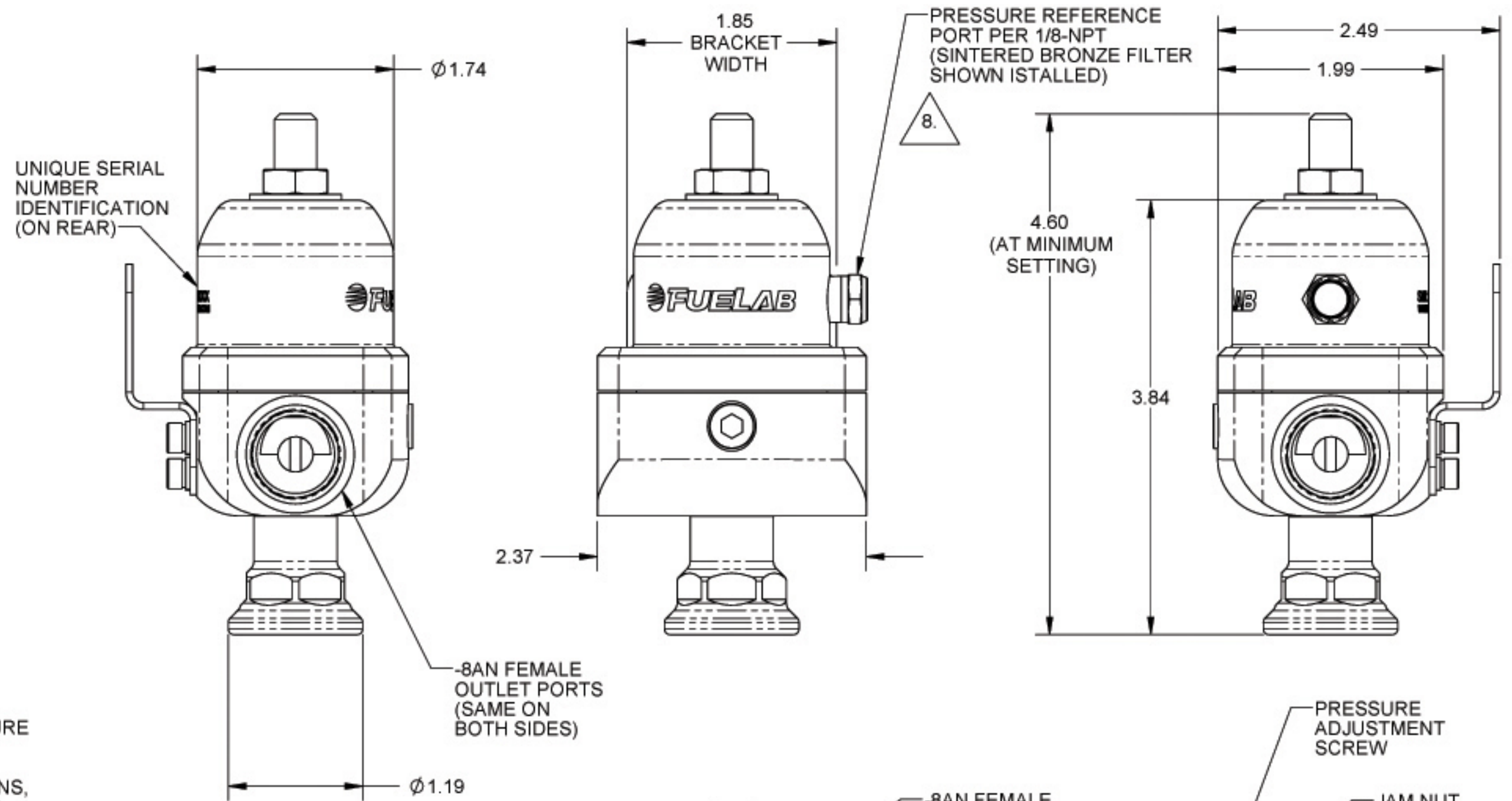

**COLOR CODE, c**

c	COVER COLOR	BODY COLOR
1	BLACK	BLACK
2	RED	CLEAR
3	BLUE	CLEAR
4	PURPLE	CLEAR
5	GOLD	BLACK
6	GREEN	CLEAR

**ISOMETRIC VIEW (ALL VIEWS SHOWN WITH HARDWARE INSTALLED)**

UNLESS OTHERWISE SPECIFIED:  
 RESPECT DWG PER AND FILE DIMENSIONS ARE IN INCHES  
 TOLERANCES:  
 FRACTIONAL: ±0.004  
 ANGULAR: ±1/2°  
 DECIMALS:  
 .1: ±0.003 .005±0.010  
 SURFACE FINISH: 125 OR BETTER  
 BREAK ALL SHARP EDGES .010 MAX  
 REMOVE ALL BURRS

THIRD ANGLE PROJECTION

DO NOT SCALE DRAWING

**FUELAB**  
 DIGITAL FUEL DELIVERY  
 Litchfield, Illinois

TITLE:  
**REGULATOR, 555xx SERIES**

SIZE: **C** DWG. NO.: **105020500** REV: \_\_\_\_\_  
 SCALE: 1/1 WEIGHT: \_\_\_\_\_ SHEET: 1 OF 1



## Operating and Installation Instructions

### **CAUTION!**

This product is to be installed only by persons knowledgeable in the repair and modification of vehicle fuel systems and general vehicle systems modification. Only a qualified technician or mechanic who is aware of applicable safety procedures should perform the installation of this product.

### **GASOLINE AND OTHER FUELS ARE FLAMMABLE AND CAN BE EXPLOSIVE!**

Perform the installation in a well ventilated location only to minimize the build up of fuel vapors. **NO** open flames, smoking or other sources of ignition are to be present during installation, to prevent fire or explosion that can cause serious injury or death. Grinding, cutting, and drilling must be performed with care to prevent ignition. Draining and removal of all fuel and ventilation of vapors in vehicle and fuel system is recommended when performing such procedures. Proper eye and personal protection is required at all times during installation.

### **WARNING!**

The Vehicle's fuel system may be under pressure! Do not loosen any fuel connections until relieving all fuel system pressure. Consult an applicable service manual for instructions to relieve fuel system pressure safely.

This product is intended for racing, off-road, or marine use only. This fuel system component is capable of altering engine tuning and therefore not legal for sale or use on emission controlled motor vehicles.

#### **Product Contents:**

Check the diagram and list of components (right) to ensure that no components are missing from box. Contact your Fuelab distributor immediately for replacement.

#### **55501-c Features and Performance Ratings:**

Inlet Port Size	-8AN Military Port
Outlet Port Sizes	-8AN Military Port
Regulation Slope	0.8 PSI/GPM
Maximum Flow Capacity	160 GPH with 20 PSI Inlet (600 LPH at 1.4 Bar Inlet)
Pressure Adjustment Range	Pressure Range "C" 4-12 PSID (.3 - .8 Bar)

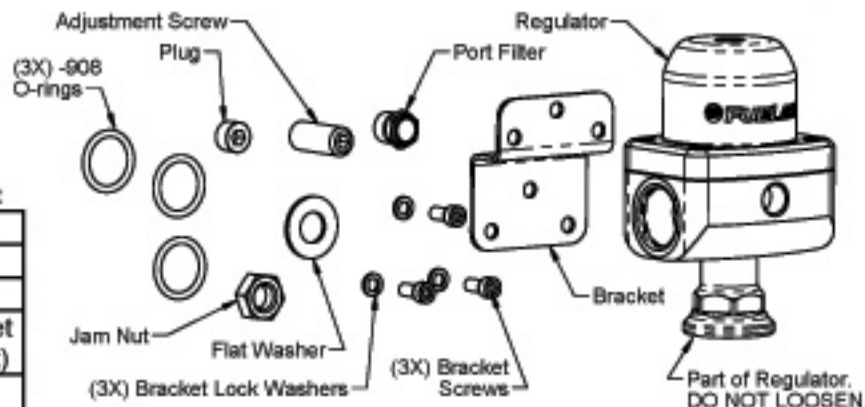

**WARNING!** Exceeding maximum inlet pressure (45 PSI) may result in an over-pressure operating condition.

#### **Before Installation, Plan Entire Fuel System:**

These instructions are limited to general topics of regulator component installation and may not include specific information pertaining to your application. These instructions are written assuming the use of an internally relieved electric fuel pump with 45 PSIG maximum outlet pressure. Some high pressure pumps may be used with regulator, but will require a bypass or relief, plumbed prior to inlet of regulator. This regulator has an internal spring that can be changed for other pressure ranges, including "L" range, for 1-3 PSID and "T" range for 10-25 PSID, if required by the specific application. Visit our company website for specific details pertaining to example fuel systems and other solution ideas. Additional information including advanced troubleshooting, any special alerts and FAQ's pertaining to this and other products is also available.

#### **General Regulator Performance Notes:**

The notation "PSIG" means pressure in Pounds per Square Inch (PSI) relative to the prevailing atmospheric condition or outside air. This is referred to as Gauge Pressure. The notation "PSID" means pressure in PSI relative to another pressure source or called the Differential Pressure (relative to *Pressure Reference Port* in case of pressure ratings). This regulator acts via restriction to control pressure (restricting fuel between inlet and outlet ports). Only "blow-through" boosted applications for carbureted systems should have a line plumbed to the pressure reference port. "Blow-through" applications will have limitations based on inlet fuel pressure and boost pressure. The amount of pressure difference to expect with application of full throttle compared to idle (for naturally aspirated engines) is a function of how much flow the engine is using (reference *Regulation Slope*, above for calculations).



### Plumbing Planning Notes:

Minimize plumbing restrictions between carburetor(s) and regulator for peak performance. Use -6AN (3/8") to -10AN (5/8") line as required per flow rate requirements of the vehicle's engine and fuel pump. See company website for nitrous oxide use and alternate plumbing schematics. See diagram on next page as well as diagram below, to identify the ports used on the regulator. Pressure is regulated by the regulator to the rest of the fuel system (from outlet ports), by restricting flow through the inlet port. Plumb the Pressure Reference Port using a fitting (Not Supplied) for "blow-through" carbureted applications only, "blow-through" means that a turbo or supercharger is used to pressurize the carburetor(s). When this occurs, fuel pressure must be compensated by the change in float bowl pressure. If motor is naturally aspirated (Normal carbureted application, with float bowl vented to atmosphere) allow this port to vent to atmosphere, do not plug or plumb to any pressure source. Use of supplied port filter is shown below. The fuel line used must handle high pressure. The use of fuel line such as stainless steel braided line and "AN" style fitting connections is recommended. The fuel ports (one -8AN Inlet Port and two -8AN Outlet Ports) use "AN" or "military" style fittings. This plumbing standard is commonly used with racing and high performance applications. See step 6 on next page for additional information on this port standard. A fuel filter with a 40 micron or lower particle rating is required to be used upstream of regulator and downstream from fuel pump to protect it and the carburetor from foreign object damage. Reference the Schematic Diagram below for filter locations. Use of a liquid filled gauge exposed to engine compartment heat is not recommended as the liquid inside the gauge may exert measurement errors. **DO NOT** plumb gauge port to any gauge mounted inside the vehicle or in passenger compartment. A line burst can spill fuel inside passenger compartment and on occupants, possibly causing serious injury or death. An electric gauge or pressure transducer system is recommended for readings in a passenger compartment.

### Typical Carbureted Fuel System Schematic Diagram:

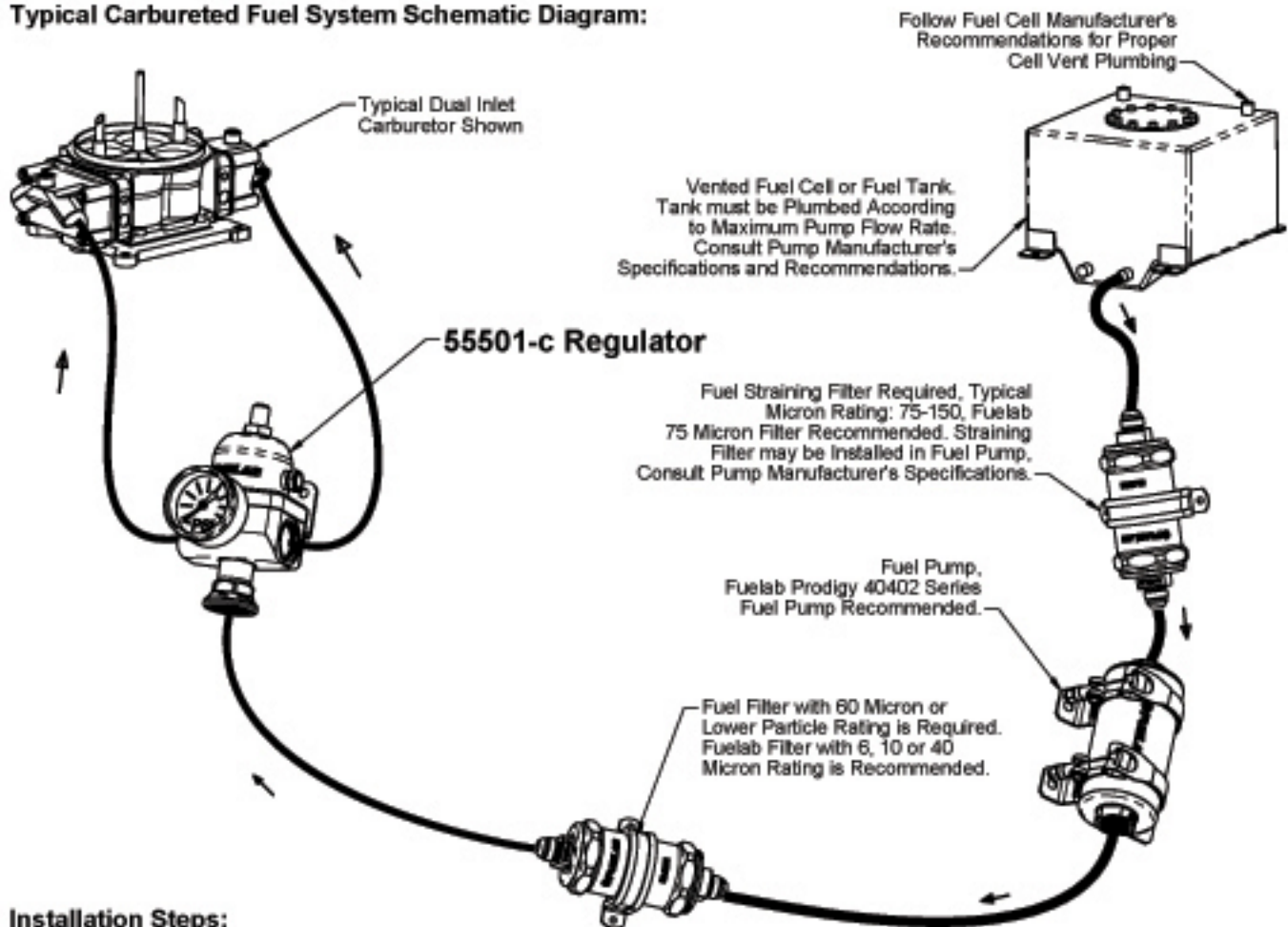

### Installation Steps:

1. Disconnect the ground terminal from battery and allow the vehicle's engine and exhaust system to cool. Relieve fuel system per applicable service manual. Follow all Warnings and Cautions written on previous page of these instructions.
2. Modify, remove or replace other fuel system components as required per established build plan (reference notes on previous page and above).
3. Use the supplied bracket as a drilling template to mark holes for mounting bracket. Choose a location that minimizes exposure to excessive heat, near carburetor(s). Mounting bracket can be modified as required.



4. Apply light oil onto the threads of the *Adjustment Screw*. Thread the *Adjustment Screw* by hand until a slight tension is felt, this position is the minimum pressure setting. Do not tighten screw any further. Pressure is to be adjusted later in these instructions. Install the *Flat Washer*, then the *Jam Nut*. Tighten the *Jam Nut* hand tight for later adjustment.
5. Install Bracket to regulator using supplied *Bracket Screws* and *Bracket Lock Washers*. Tighten *Bracket Screws* between 25-40 in-oz of torque (snug, do not over tighten screws).
6. Install the fuel fittings (not supplied). The threads used on these *Fuel Ports* are not tapered or pipe threads. Do not use Teflon<sup>®</sup> thread tape or thread sealant on these threads, as this can cause leakage or introduce debris into the fuel system. Fittings to be used with these style of ports require use of the enclosed-906 *O-rings* for proper sealing (reference diagrams, below). Use light oil to lubricate the *O-rings* just prior to installation. Install the *O-rings* onto the fuel fitting first. Position the *O-ring* in the thread relief of the fitting as shown in the diagram, below. Thread fitting into regulator and tighten between 5 and 15 ft-lbs of torque.
7. Use Teflon<sup>®</sup> tape or thread sealant on all 1/8"-NPT fittings to be used for the *Gauge Port* and *Pressure Reference Port* (see diagrams, below). Install fittings or plug as required. If pressure reference port is not plumbed, then install the *Sintered Bronze Filter* (supplied) and allow fitting to vent to atmosphere (do not plumb or plug port). Use of *Port Filter* (only) does not require the use of Teflon<sup>®</sup> tape or thread sealant. For extra level of safety, pressure reference port can be plumbed with float bowl vent, in case of rare diaphragm failure.
8. Install regulator assembly into vehicle, fastening the bracket to the vehicle. Attach fuel lines, *Gauge Port* line (if external pressure gauge is used in application) and *Pressure Reference Port* line (if applicable). Boosted applications (such as turbo or supercharger) will require a hose clamp on barbed fitting to prevent hose from coming loose. Use of -3AN or -4AN fitting and line can also be used as a substitute to the barbed fitting.

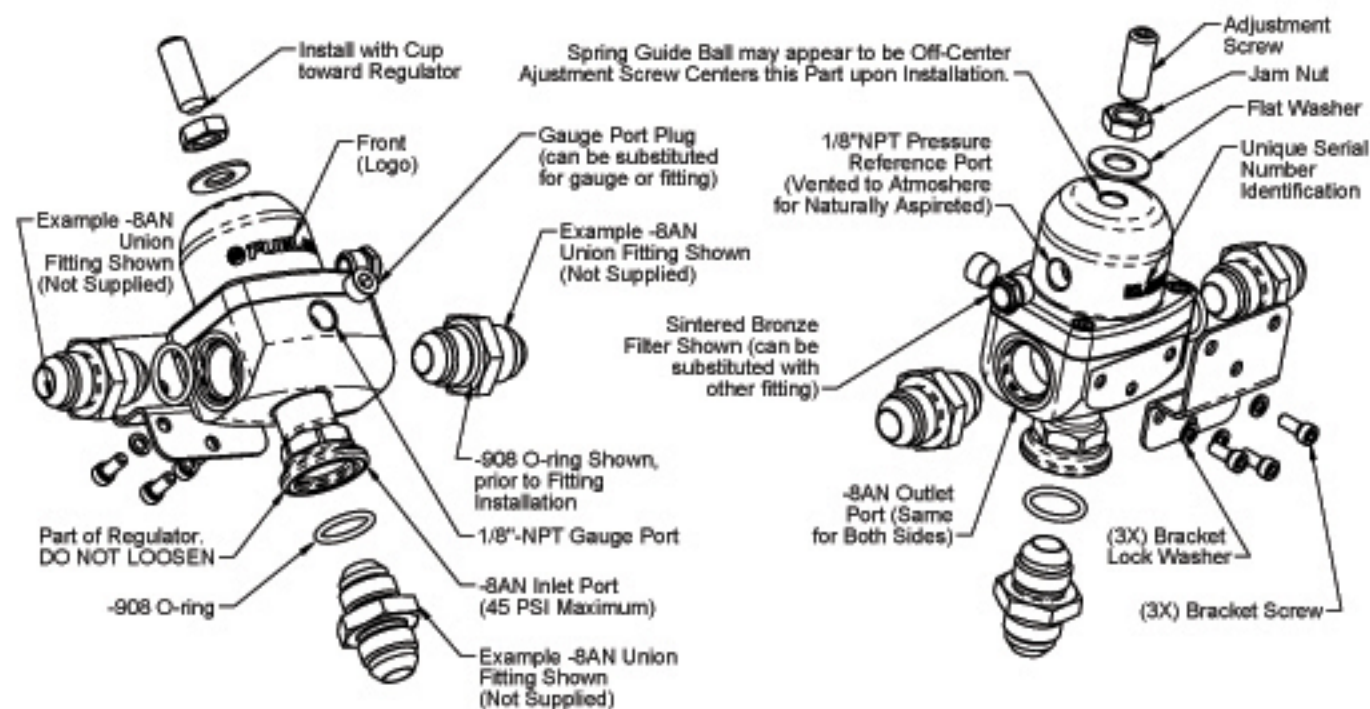

9. Inspect fuel system for any contact of fuel lines or wires with other components that can cause chafing or rubbing. Secure all components and fuel lines.
10. Connect the vehicle's battery. If the float bowls of the carburetor are empty, then the fuel system can typically be self-primed. If the float bowls are full, then fuel system may have trouble priming. One of the outlet fuel lines can be used to purge system through fuel collector for initial priming. Start engine and fuel pump, while monitoring fuel pressure. The pump will have to operate several seconds (60+) to prime and drive air out of the fuel system. Fuel system pressure should read about 4-5 PSIG (use an external gauge for adjustment if a permanent gauge is not used). Inspect vehicle for any leaks. Turn off fuel system and repair any leaks that may be present before continuing.
11. When adjusting pressure, be sure that fuel pump and engine are operating to monitor pressure. Increase pressure by rotating adjustment clockwise. Do not thread *Adjustment Screw* past jam nut within 1/8". Over tightening the adjustment screw can damage the regulator. For repeatable readings, engine should be operating normally at idle. If the fuel system is not flowing (such as engine running) then adjustment will be difficult, especially when trying to lower fuel pressure.
12. After final adjustment of fuel pressure, to desired level, tighten *Jam Nut*. Road test vehicle, and retest pressure upon return to ensure accurate adjustment.



## LIMITED WARRANTY

FUELAB, a division of FCP, Inc., having its principal place of business at 826A Morton Court, Litchfield, IL 62056, USA ("Manufacturer") warrants its FUELAB products (the "Products") as follows:

### 1. Limited Warranty.

Manufacturer warrants that the Products sold hereunder will be free from defects in material and workmanship for a period of 2 Years from the date of purchase to the original purchaser. If the Products do not conform to this Limited Warranty during the warranty period (as herein above specified), Buyer shall notify Manufacturer in writing, or by phone, of the claimed defects and demonstrate to Manufacturer satisfaction that said defects are covered by this Limited Warranty. If the defects are properly reported to Manufacturer within the warranty period, and the defects are of such type and nature as to be covered by this warranty, Manufacturer shall, at its own expense, furnish replacement Products or, at Manufacturer's option, replacement parts for the defective Products. Removal of Products from vehicle (*Vehicle means any automotive, bike or marine transportation powered by an internal combustion engine. This product is NOT intended or designed for use on aircraft, experimental or otherwise.*), shipping to Manufacturer and installation of the replacement Products or replacement parts shall be at Buyer's expense.

### 2. Other Limits.

THE FOREGOING IS IN LIEU OF ALL OTHER WARRANTIES, EXPRESS OR IMPLIED, INCLUDING BUT NOT LIMITED TO THE IMPLIED WARRANTIES OF MERCHANTABILITY AND FITNESS FOR A PARTICULAR PURPOSE. Manufacturer does not warrant against damages or defects arising out of improper or abnormal use or handling of the Products; against defects or damages arising from improper installation (where installation is by persons other than Manufacturer), against defects in products or components not manufactured by Manufacturer, or against damages resulting from such non-Manufacturer made products or components. Manufacturer passes on to Buyer the warranty it received (if any) from the maker thereof of such non-Manufacturer made products or components. This warranty also does not apply to Products upon which repairs have been effected or attempted by persons other than pursuant to written authorization by Manufacturer.

### 3. Exclusive Obligation.

THIS WARRANTY IS EXCLUSIVE. The sole and exclusive obligation of Manufacturer shall be to repair or replace the defective Products in the manner and for the period provided above. Manufacturer shall not have any other obligation with respect to the Products or any part thereof, whether based on contract, tort, strict liability or otherwise. Under no circumstances, whether based on this Limited Warranty or otherwise, shall Manufacturer be liable for incidental, special, or consequential damages.

### 4. Other Statements.

Manufacturer's employees, representatives' and/or resellers ORAL OR OTHER WRITTEN STATEMENTS DO NOT CONSTITUTE WARRANTIES, shall not be relied upon by Buyer, and are not a part of the contract for sale or this limited warranty.

### 5. Entire Obligation.

This Limited Warranty states the entire obligation of Manufacturer with respect to the Products. If any part of this Limited Warranty is determined to be void or illegal, the remainder shall remain in full force and effect.

### 6. Warranty Service

**What Does This Warranty Not Cover?** Any problem that is caused by abuse, misuse, or an act of God (such as a flood) is not covered. Also, consequential and incidental damages are not recoverable under this warranty. Some states do not allow the exclusion or limitation of incidental or consequential damages, so the above limitation or exclusion may not apply to you.

**How Do You Get Service?** In order to be eligible for service under this warranty you **MUST** return the Warranty Registration card, or register on-line at [www.fuelab.com/warranty](http://www.fuelab.com/warranty) within 30 days of purchasing the Product.

If something goes wrong with your product contact FUELAB at 1-800-541-2345, International customers call 001-217-324-3737, for a Return Authorization Number (RMA). After receiving your RMA send it postage paid, fully insured, with a brief written description of the problem to:

FUELAB Warranty Department, 826A Morton Court, Litchfield, IL 62056

We will inspect your Product and contact you within 72 hours of receipt to give the results of our inspection and an estimate of the labor and/or parts charges required to fix the Product, if applicable. If covered under this limited warranty Manufacturer will repair Product and return it to you at no cost. If the Product is NOT covered under this warranty and if you authorize repairs, we will return the repaired Product to you COD, or prepaid via credit card, within 72 hours. There is no charge for inspection. If return product is found to be free of defects a \$25.00 shipping and handling charge will be applied. We will return the repaired Product to you COD, or prepaid via credit card, within 72 hours.