



INSTALLATION INSTRUCTIONS

PART NUMBER 140008

ELECTRONIC SUPER COIL

The ACCEL Electronic Super Coil is a bolt-in high performance automotive coil which replaces original equipment coils for electronic computer ignition without cutting or splicing of your vehicle's harness. The red and black leads of the factory-style ACCEL harness connectors are identified for easy hook-up to the Super Coil.

Due to the high energy output, the Electronic Super Coil is supplied with ACCEL's 8.8 coil wire. The high strength injection molded case is designed for super-duty service along with cooling fins for efficient heat dissipation. Self-tapping mounting screws and an easy-to-read mounting template is included.

Reading these instructions before starting the installation will assure that you will be able to take maximum advantage of all the performance that your ACCEL Electronic Super Coil was designed to deliver.

STEP 1

Locate coil and remove ignition coil wire.

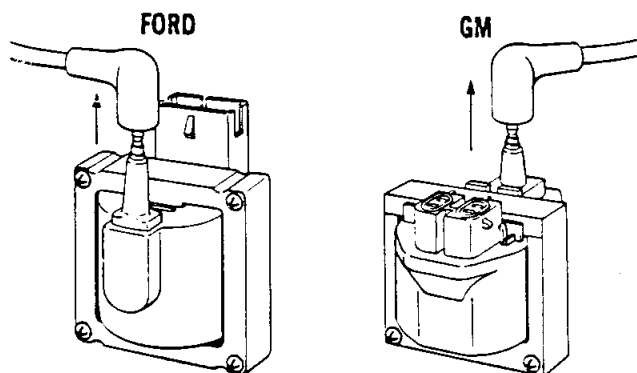

STEP 2

Disconnect connectors by carefully inserting a screwdriver between the connector lock tabs and with a twisting motion carefully pull upward. You might need to release one side at a time.

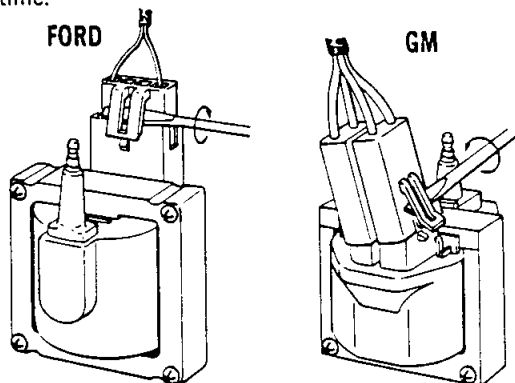

STEP 3

Carefully remove the mounting screws and remove stock coil.

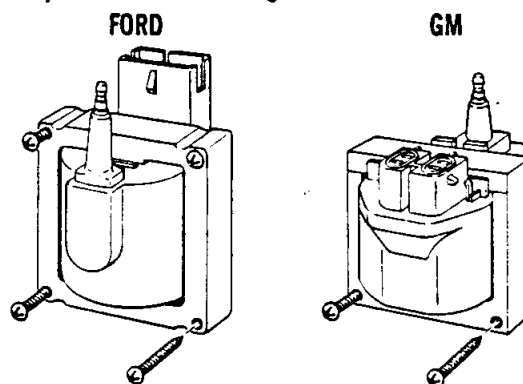

STEP 4

Choose an area on the firewall or fender well where the coil may be mounted with no interference from linkage, air conditioning hoses, heater hoses, etc. and no further than 20" from the distributor. (Please note that the ACCEL Electronic Super Coil may not fit into your original equipment mounting bracket) Use the template on back to determine placement of the 4 self-tapping screws. Before drilling holes, please check and be aware of what you are drilling into as not to damage a component that may be under or in line with a mounting hole.

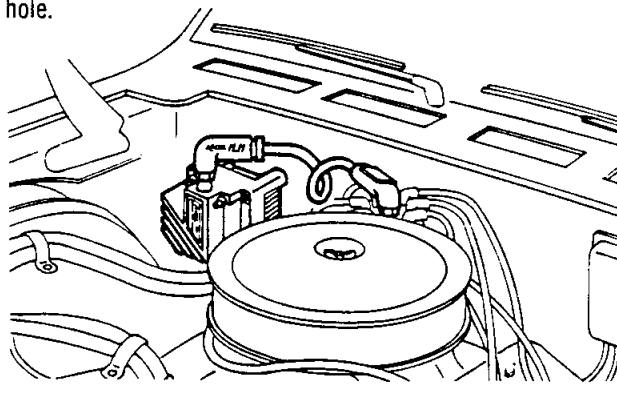

STEP 5

The ACCEL connector is supplied with two terminated ends, one GM, one Ford, as per the below installation. Cut off the end that is not needed for your application and discard.

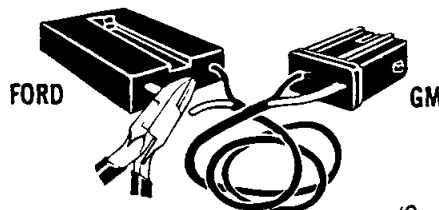

(Over Please)

Then carefully plug the ACCEL connector into the original factory harness connector. **DO NOT FORCE.** The ACCEL connector is manufactured to insert in only one direction.

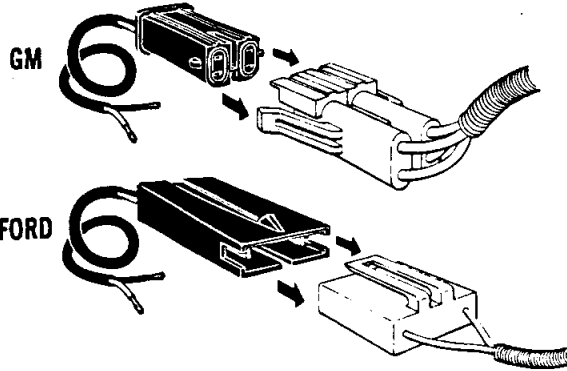

STEP 7

Once connected, measure and terminate the red (+) and black (-) leads, with the supplied ring terminals and connect them to the + and - studs of the Super Coil. **NOTE: DO NOT OVER TIGHTEN TERMINAL NUTS.**

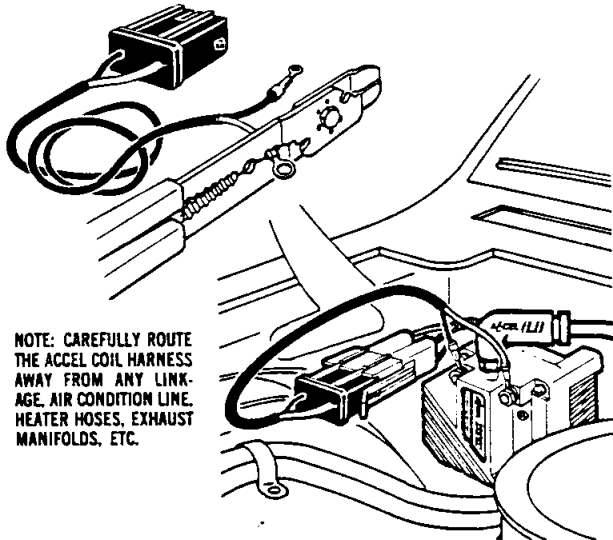

NOTE: CAREFULLY ROUTE THE ACCEL COIL HARNESS AWAY FROM ANY LINKAGE, AIR CONDITION LINE, HEATER HOSES, EXHAUST MANIFOLDS, ETC.

STEP 8

Connect the ACCEL 8.8 coil wire to the Super Coil and measure the length needed to the distributor cap. Once determined, cut and terminate as follows (in Step 9) with supplied terminals.

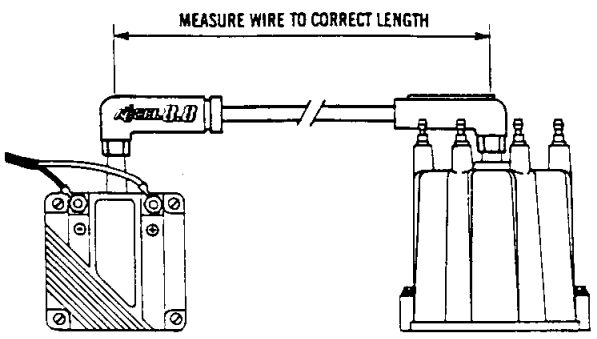

Strip wire to expose 3/8 to 1/2 inch of conductor.

DO NOT SLIT CORE

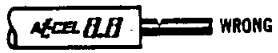

DO NOT SHRED OR STRIP AWAY CORE



A. Bend conductor over wire and insert into terminal.

B. Bend terminal tabs over with pliers.

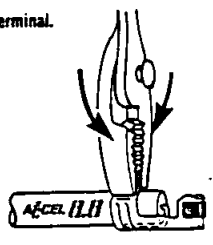

C. Lightly lubricate the terminal with the dielectric grease included and slide the wire into the HEI boot.

D. Small amounts of dielectric grease may also be applied inside of boots on both spark plug and distributor cap ends to stop any high voltage leakage.

E. Be sure you have made a good connection in the distributor cap and coil. You should recheck these connections periodically. If connector in distributor cap or coil is gray-green, "or appear corroded" you may have a poor connection.



Once all steps have been completed and final checks have been made on mounting and wiring, you are now ready for operation.

SUPER COIL MOUNTING TEMPLATE

