



## INSTALLATION INSTRUCTIONS

# Distributor Gear/Coupling Instructions

Some Mallory distributors and magneto bases are not equipped with a drive gear or coupler. If your original distributor is equipped with a drive gear or coupler and the Mallory distributor is not, remove the gear or coupling from the original distributor and install it on the Mallory distributor. Follow the instructions listed below.

### Step 1

Remove the gear or coupler from the OEM distributor by pressing or punching out the roll pin.

**NOTE: Remove and retain the thrust washer located just above the gear/coupler.**

### Step 2

Grasp the Mallory distributor or magneto base at the housing and pull down on the shaft to remove all slack (Figure 1).

### Step 3

Install the OEM thrust washer and gear/coupler onto the Mallory distributor or magneto by sliding them onto the shaft. Push on the shaft from above while holding the thrust washer and gear against the housing to remove all slack (Figure 2).

**FIGURE 1**

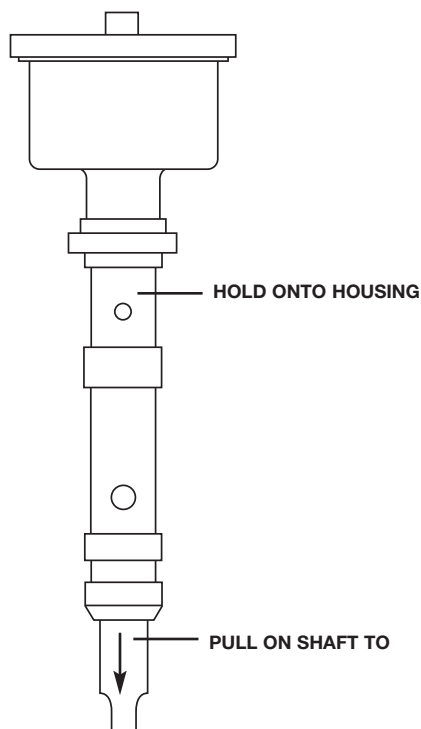

### Step 4

Pull the gear/coupler away from housing enough to insert a .020" feeler gauge (Figure 3). After inserting feeler gauge, press on both ends of distributor or magneto to remove all slack.

### Step 5

Using the hole in the OEM gear/coupler as a guide, drill a hole through the Mallory shaft using a drill bit the exact size of the hole in the OEM distributor shaft (Figure 4).

**NOTE:** Ensure that all slack is removed and feeler gauge remains in place while drilling. We strongly recommend using a drill press for this procedure.

### Step 6

Press a new roll pin (the same size as the OEM pin) into gear/coupler shaft. Remove the feeler gauge. The gear/coupler should be pinned to the shaft and the gear should move .010" to .030" relative to the housing.

**FIGURE 2**

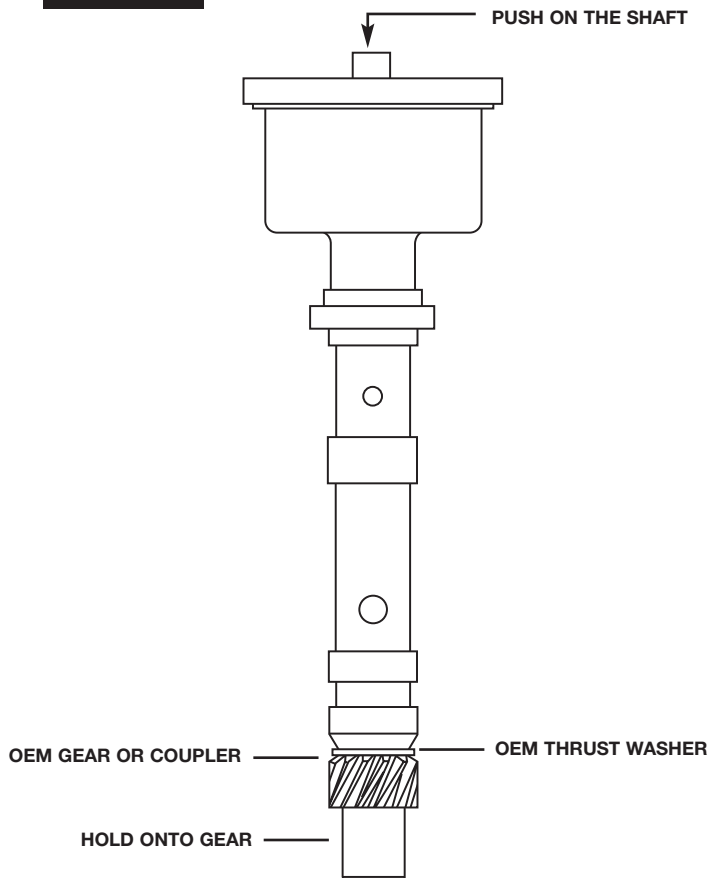

**FIGURE 3**

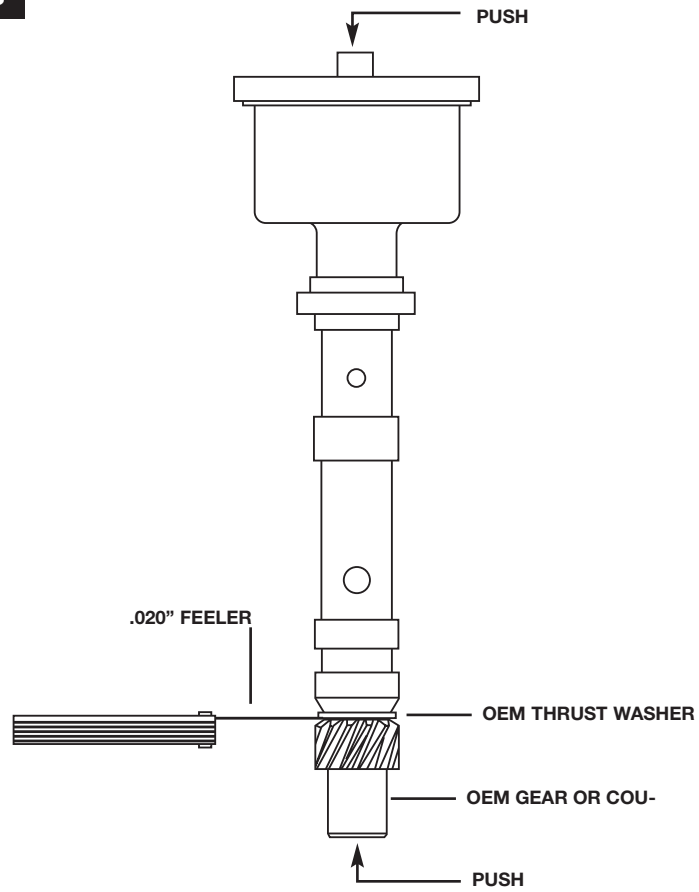

**FIGURE 4**

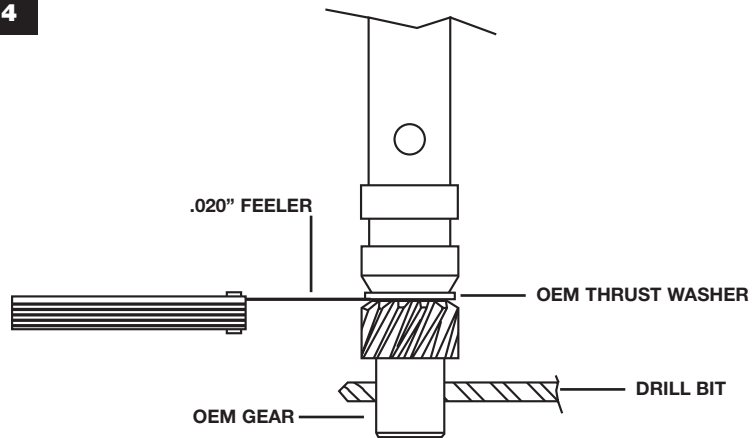

MALLORY IS A DIVISION OF THE MR. GASKET PERFORMANCE GROUP  
10601 MEMPHIS AVE. #12, CLEVELAND, OH 44144  
216.688.8300 FAX 216.688.8306  
www.malloryracing.com

FORM 854  
04/05  
Made in U.S.A.  
Printed in U.S.A.