

# MSD INSTALLATION INSTRUCTIONS

## MSD LS Coil Covers PN 2970, PN 29701, PN 2971, PN 29711, PN 2972 and PN 29721

**ONLINE PRODUCT REGISTRATION:** Register your MSD product online. Registering your product will help if there is ever a warranty issue with your product and helps the MSD R&D team create new products that you ask for! Go to [www.msperformance.com/registration](http://www.msperformance.com/registration).

### Parts Included:

4 - Coil Cover Mounting Brackets  
4 - Fuel Rail Mount Clips  
8 Coil Mounting Bracket Bolgs  
12 Fuel Rail Mount Clip Screws

### Parts needed but not included:

MSD Atomic LS EFI fuel rails and fuel rail covers

### WARNING

Installation of this product requires detailed knowledge of automotive systems and repair procedures. Installation of fuel system parts and any fuel tank modifications must be carried out by a qualified automotive technician. Installation of fuel system parts requires handling of gasoline. Ensure that work is performed in a well ventilated area with an approved fire extinguisher nearby. Extinguish all open flames, prohibit smoking and eliminate all sources of ignition in the area of the vehicle before beginning the installation.

When working with fuel systems, eye goggles and other safety apparel should be worn to protect against debris and sprayed gasoline. The finished work must be thoroughly checked to ensure there are no fuel leaks.

## INSTALLATION OF MOUNTING HARDWARE

Installation will require removal of the Atomic LS fuel rails from the engine if they are already installed.

## REMOVAL OF THE ATOMIC LS FUEL RAIL COVERS

Follow these steps to remove both covers. To install the covers reverse the steps.

1. Remove the 4 screws holding the covers to the fuel rail and lift the cover to clear rail.
2. When the cover is clear of the fuel rail push the cover towards the manifold until it disengages from the lip of the rail
3. Lift the cover straight up.

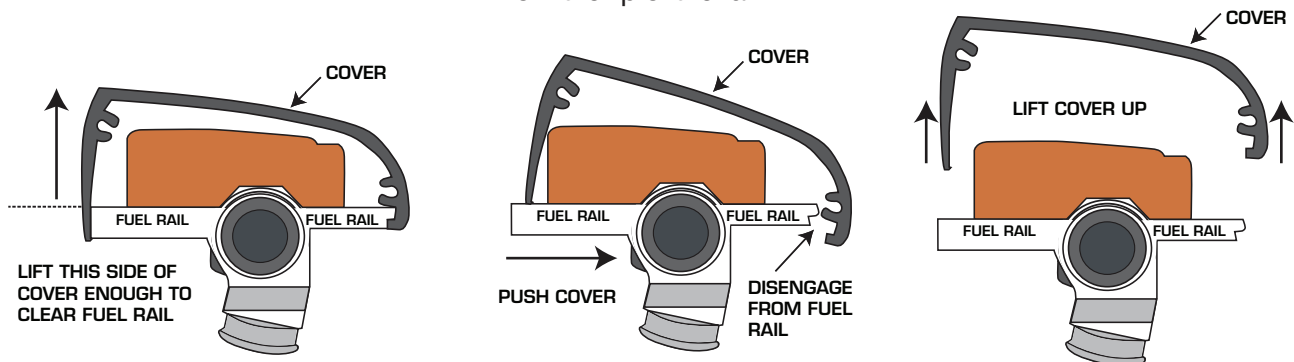

## REMOVAL OF THE ATOMIC LS FUEL RAILS:

**Note:** Disconnect the negative battery terminal before performing the removal procedure. Caution should be taken when disassembling the fuel rails assembly. Be prepared to catch fuel when removing fuel lines.

Disconnect the fuel lines from the fuel rails. Disconnect all of electrical connectors from the fuel rails. Remove the eight fuel rail retaining bolts and gently pull the rails away from the manifold.

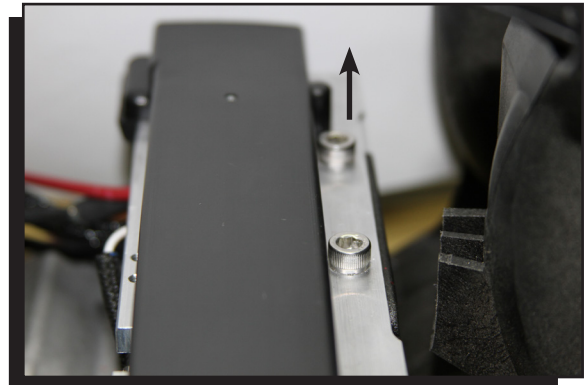

Figure 1

Turn the fuel rail upside down, and install two fuel rail mount clips on each fuel rail using the supplied screws Figure 2. Torque the fuel rail mounting clip screws to XX lb-in.

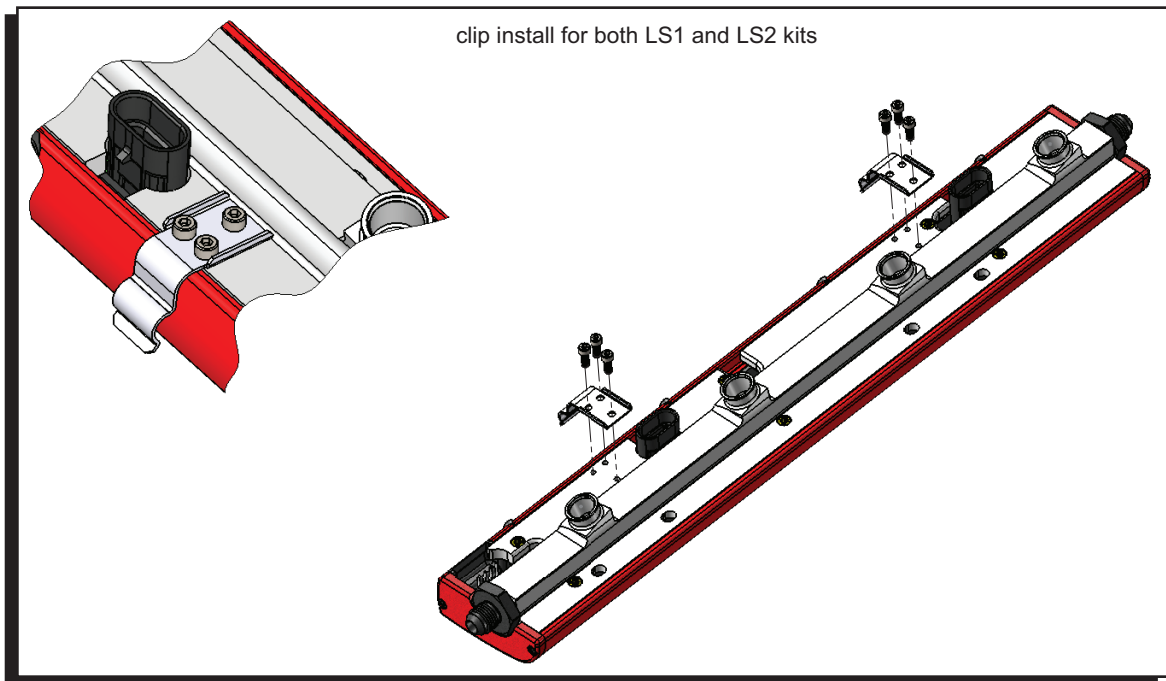

Figure 2

## REINSTALLATION OF THE FUEL RAILS IS THE REVERSE OF REMOVAL.

**Note:** Check for fuel leaks before attempting to start the engine or finish the installation. Reconnect the battery negative cable and cycle the ignition a few times to allow fuel pressure to build in the lines.

**COIL COVER BRACKET INSTALLATION:**

Unbolt the coils for cylinders #1, #2, #5, #6. Remove the coil retainer bolts, place the brackets over the coils and reinstall the bolts. Ensure the open end of the brackets face towards the front of the engine. Torque the bolts to XX ft-lb (Figure 3).

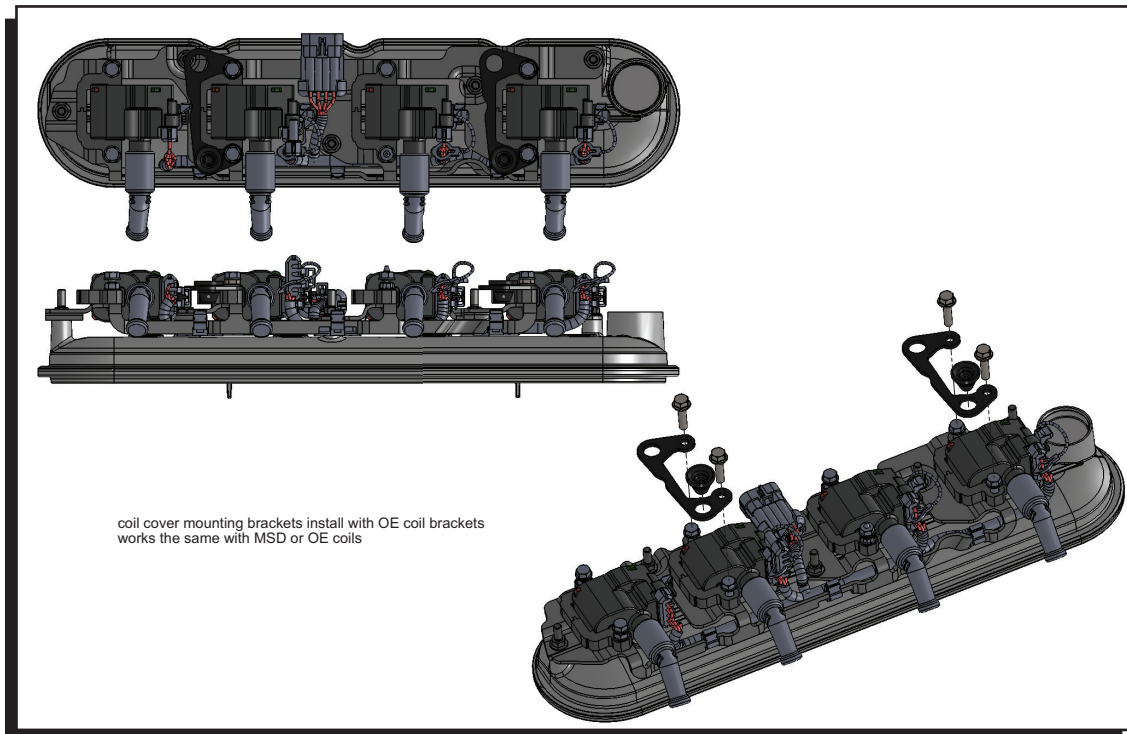

Figure 3

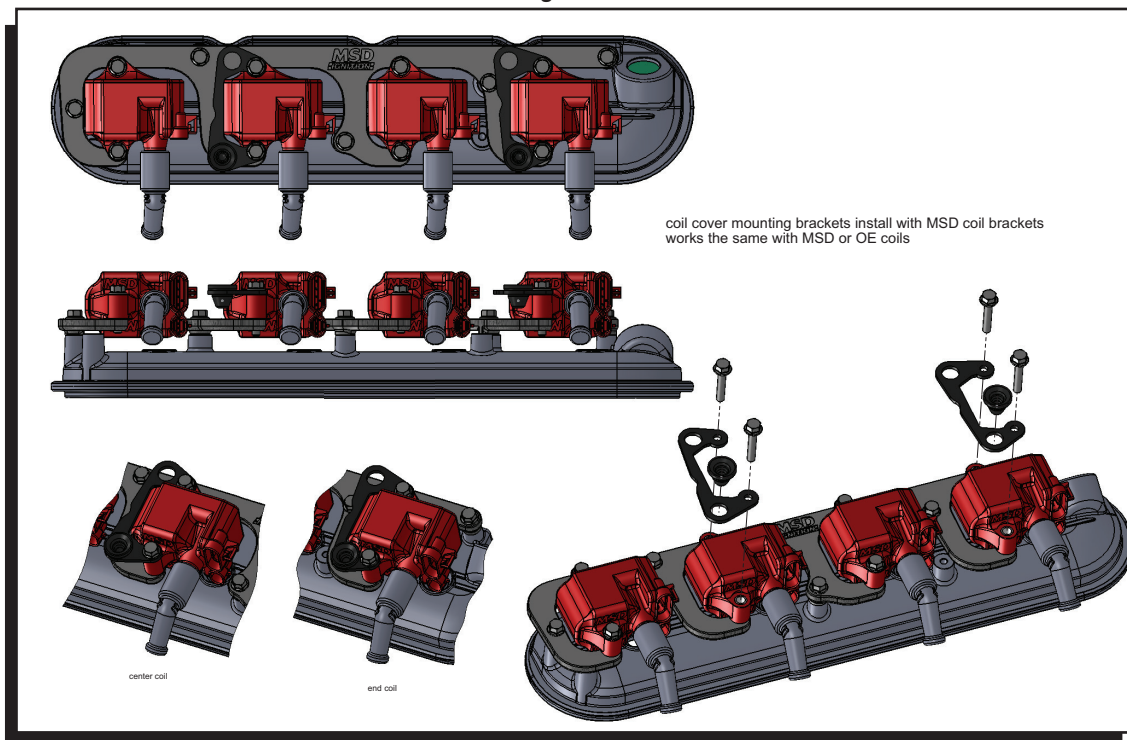

Figure 4

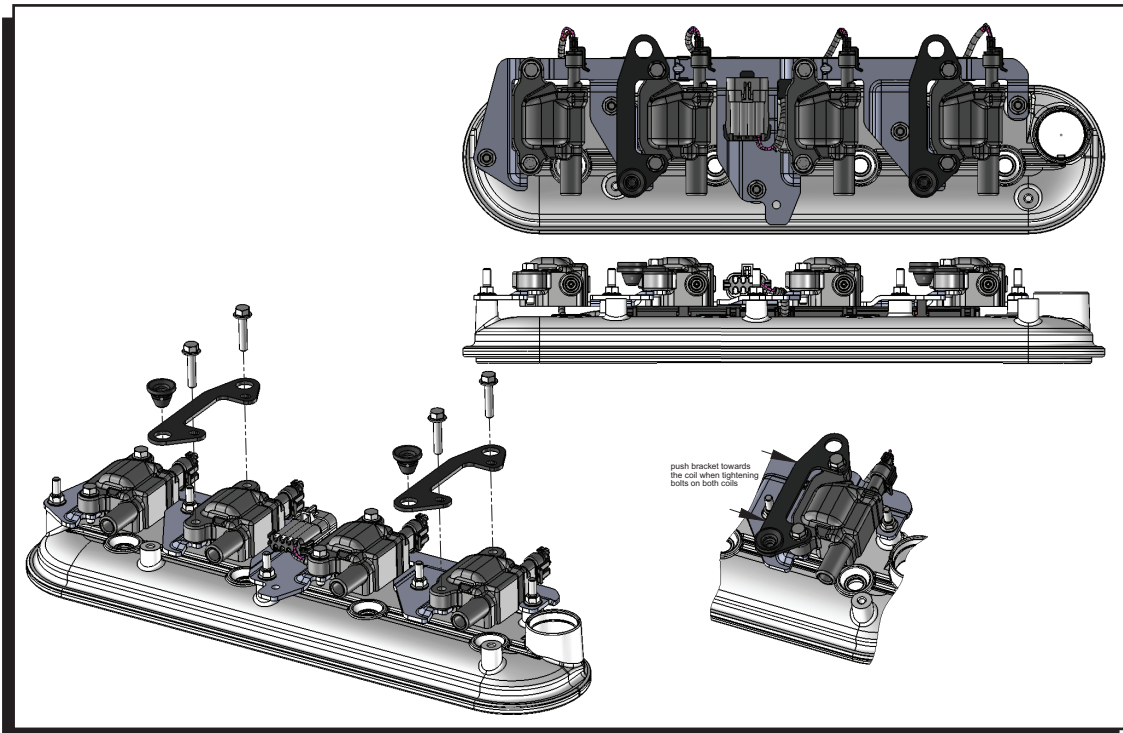

Figure ?

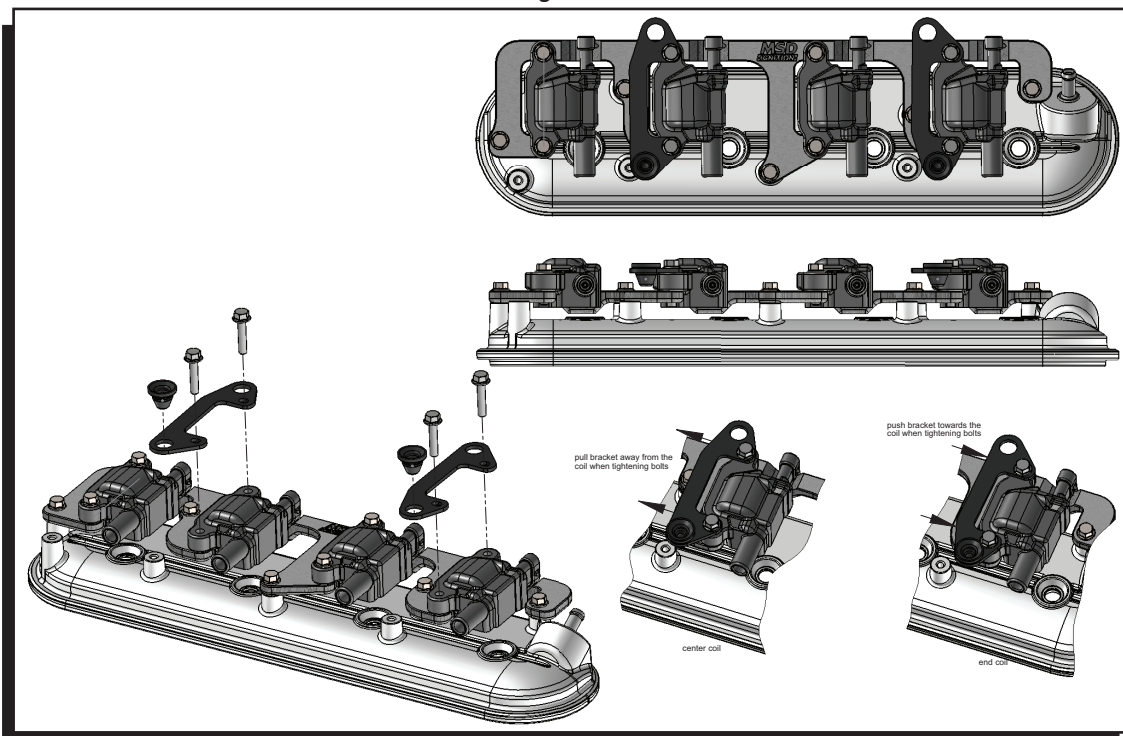

Figure ?

**MOUNTING THE COIL COVERS:**

Position the cover horizontally centered against the fuel rail cover. Press the top parts of the cover. The cover should snap into the fuel rail retaining clips (Figure ?).

Press the bottom cover down until the balls cast into the cover plate snap into the rubber grommet (Figure ?).

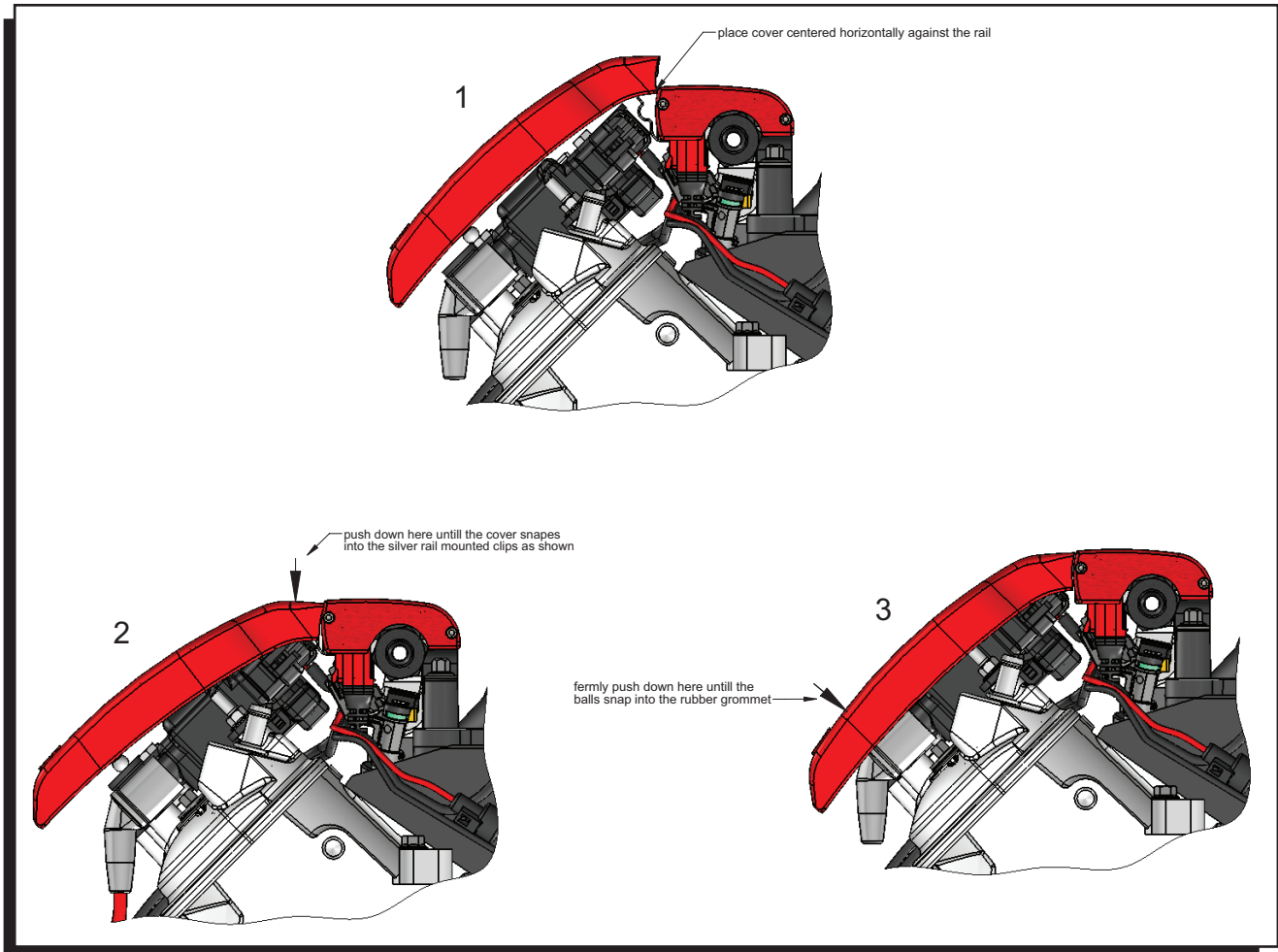

Figure ?





