

MSD **IGNITION** **INSTALLATION INSTRUCTIONS**

Crimping with the MSD Mini-Stripper-Crimper PN 3503

Tools Required:

Razor Blade

Vise (4" Minimum)

Needle Nose Pliers

Note: MSD offers a dielectric grease called Spark Guard, PN 8804. A drop of this grease will ease installation of the boots. It also helps stop voltage leaks, prevent moisture build up and eases removal of the wire from its connection.

The Mini-Stripper-Crimper is an all in one spark plug wire stripper and crimp tool. It will work with both MSD 8.5mm Super Conductor and 8mm Heli-Core wires to produce a strong, professional crimp.

TERMINALS

MSD offers several different terminals with our Universal wire sets. There are two terminal styles used, either a standard style or the Dual Crimp Terminal (Figure 1). The standard design requires stripping more of the wire sleeve because the conductor will be bent under the terminal. The Dual Crimp has specific crimp tabs for the conductor which require needle nose pliers.

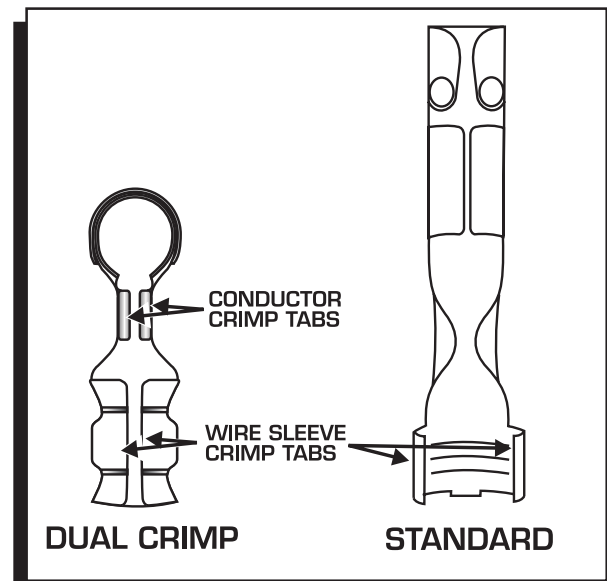

Figure 1 Identifying the Different Style Terminals.

STRIPPING THE WIRE

1. Once you've determined which terminals you are working with, position the wire in the corresponding strip guide. There are two holes; one for the 8mm wire and another for the 8.5mm wire.
2. There are two stripping positions indicated on the stripping slot, depending on the terminal being used. Slide the wire to the correct position and strip the sleeve by holding a razor blade flush with the strip guide and rotate the wire 360° (Figure 2).
3. Remove the wire and twist the cut end of the sleeve off in a counterclockwise direction.

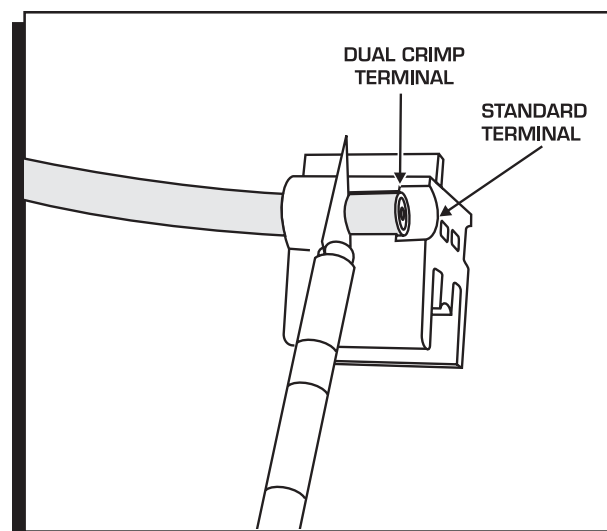

Figure 2 Stripping the Sleeve.

CRIMPING

To achieve the strongest crimp possible, it is required to bend the crimp tabs over about 90° using needle nose pliers (Figure 3). Follow the instructions for the terminal you are using.

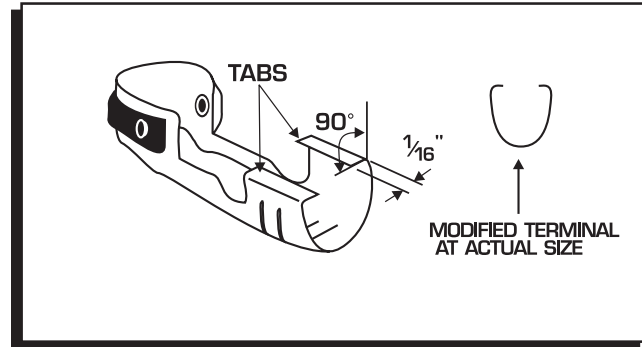

Figure 3 Preparing the Terminals.

STANDARD TERMINALS

1. After stripping the sleeve, fold the conductor back along the wire insulation (Figure 4).
2. Do not allow the conductor to pull tightly against the insulation. A small gap around the conductor should be present before crimping. Slide the wire into the terminal with the conductor positioned so it is in contact with the bottom of the terminal. Position the wire through until the insulation protrudes about 1/8" beyond the crimp tabs.
3. Position the wire and terminal into the "W" groove of the Mini-Stripper Crimper and proceed to Step 4.

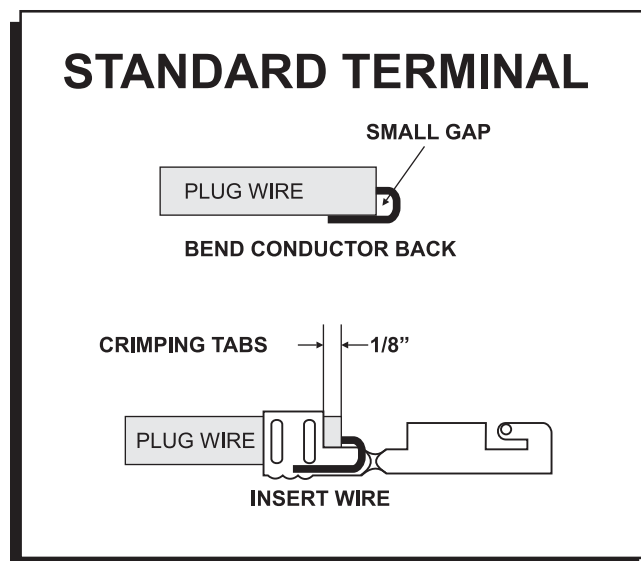

Figure 4 Positioning the Wire in the Terminal.

DUAL CRIMP TERMINALS

1. After stripping the sleeve, position the wire in the terminal so the insulation protrudes about 1/8" beyond the insulation crimp tabs and the conductor extends about 1/8" past the conductor crimp tabs (Figure 5).
2. Position the wire and terminal into the "W" groove of the Mini-Stripper Crimper and follow Steps 4 - 6 to crimp the terminal to the sleeve.

Note: It is normal for the conductor to retract into the insulation slightly as the sleeve crimp is made.

3. After the sleeve is crimped, push the conductor between the crimp tabs and use a set of needlenose pliers to crimp them together. **DO NOT OVER CRIMP.**

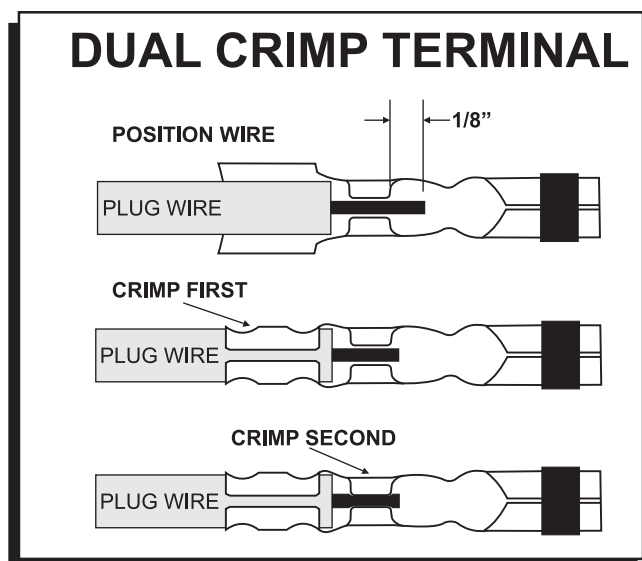

Figure 5 Crimping a Dual Crimp Terminal

4. Slide the other part of the Mini-Stripper-Crimper over the wire terminal and lightly press them together (Figure 6).
5. Put the assembly into a vise making sure the alignment tabs are on the outside edge of the vise jaws (Figure 7).
6. Slowly close the vise making sure the tool and terminal stay properly positioned and aligned (Figure 8). Stop applying pressure when the terminal ends have wrapped securely around the sleeve and grip the wire.

Note: DO NOT OVER CRIMP! It is possible to tear the sleeve of the wire by excessive pressure on the vise. This will cause a weaker crimp.

7. Back off the vise and remove the wire from the Crimper. Gently tug the terminal and inspect the position of the conductor to make sure the crimp is solid and firm.

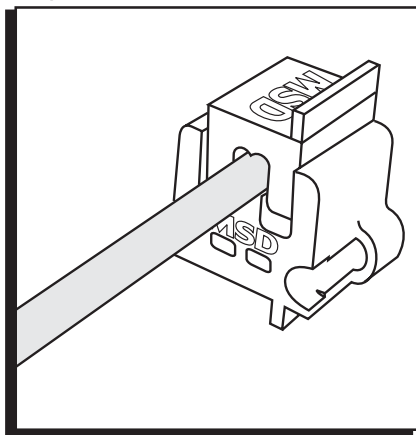

Figure 6 Aligning the Terminal in the Tool.

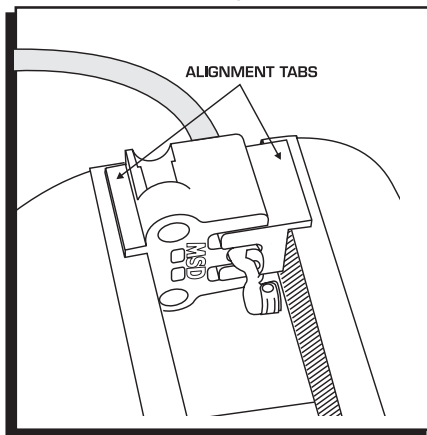

Figure 7 Preparing to Crimp in the Vise.

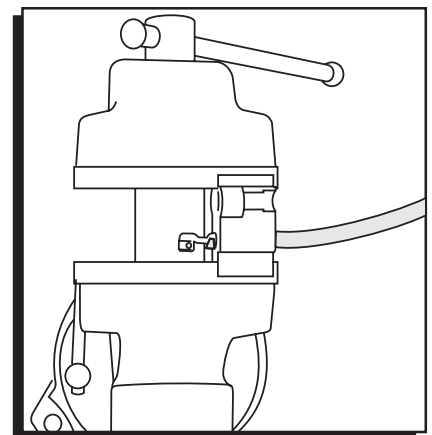

Figure 8 Crimping with the Vise.

INSTALLING THE BOOT

To ease installation of the boots, use a drop of a dielectric grease such as MSD's Spark Guard, PN 8804. If you are installing the brass 90° socket style terminals, slide the terminal all the way through the boot, then grip the terminal near the wire crimp and bend it over 90° and slide the boot down (Figure 9).

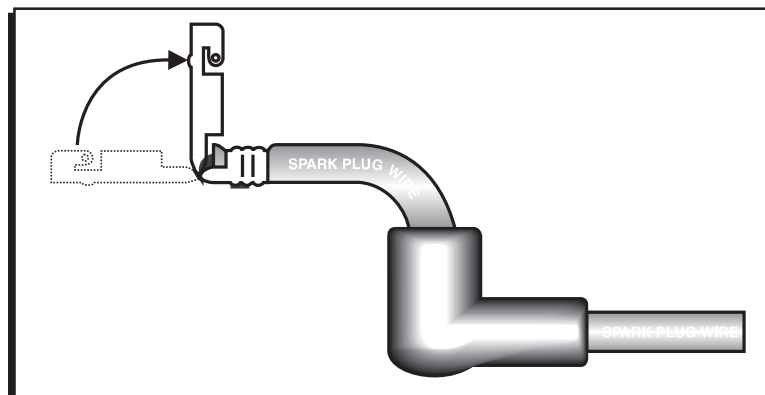

Figure 9 Installing the Boots.

If you build a lot of custom spark plug wire sets, MSD offers a professional tool, the Pro-Crimp Tool, PN 3505.

