

# **MSD** INSTALLATION INSTRUCTIONS

## **Solid State Relay Block PN 7564**

**ONLINE PRODUCT REGISTRATION:** Register your MSD product online. Registering your product will help if there is ever a warranty issue with your product and helps the MSD R&D team create new products that you ask for! Go to [www.msperformance.com/registration](http://www.msperformance.com/registration).

### **Parts Included:**

- 1 - MSD Solid State Relay Module
- 1 - Mounting Kit

**WARNING:** During installation, disconnect the battery cables. When disconnecting, always remove the Negative cable first and install it last.

### **FEATURES**

- 5 to 20 volt supply
- Four Independent 20A branches
- Automatic Over-temp Protection
- Short circuit protection
- Versatile mounting options
- Single-wire activation by switching power or ground
- LED Status indicators
- Combined total continuous current rating of 80 amps



**Figure 1 PN 7564 Stand Alone Solid State Relay**

### **OPERATION**

The main power supply to the unit should originate at the positive battery post. There are four independent branches. Each branch is thermally protected against overload and electrical short. Once the protection circuit has tripped, the activation signal needs to be removed and re-applied to reset the affected channel(s).

### **MOUNTING**

The Solid State Relay Module must be mounted in a sturdy, dry location and away from extreme heat. The unit should not be immersed or subjected to direct spray from a power washer.

### **WARNING: LIVE BATTERY POWER:**

Failure to follow these warnings may cause fire, injury, property damage, or even death.

All connections must be properly secured.

Use only automotive grade wire with adequate heat and fluid resistance.

All wire gauges must be adequate for the current in the application.

### **WIRE SIZE SELECTION GUIDE**

Current Rating AMP	Minimum Wire Size AWG
80	4
60	6
20	12

## WIRING

The main power feed and distribution wires, connected to the large terminals, must be sized according to the Wire Size Selection Guide on Page 1. All other wires (ground and activation / deactivation) can be 18-22 AWG.

1. Connect the small right terminal, marked "G", in the lower level to a good engine ground (Figure 2)

**WARNINGS:** Attach the power wire to the BATT terminal before connecting it to the battery post.

Remove the power wire from the battery post before removing it from the BATT terminal

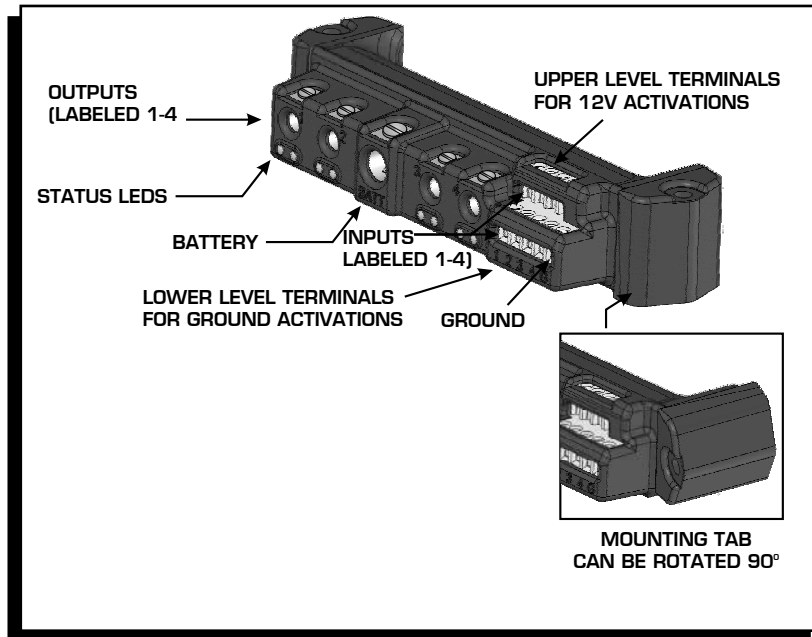

**Figure 2 Solid State Relay.**

2. Securely connect the BATT terminal to the positive battery post. Use the wire size selection guide to choose the appropriate wire.
3. Each output branch can be activated by one of two configurations, ground or 12 volts.

**Note A:** The lower right terminal marked "G" must be grounded for either configuration (Figure 3 & 4).

**Note B:** 12V Activation - apply 12V to the appropriate upper level terminal, 1-4 (Figure 3).

**Note C:** Ground Activation - apply ground to the appropriate lower level terminal, 1-4 (Figure 4).

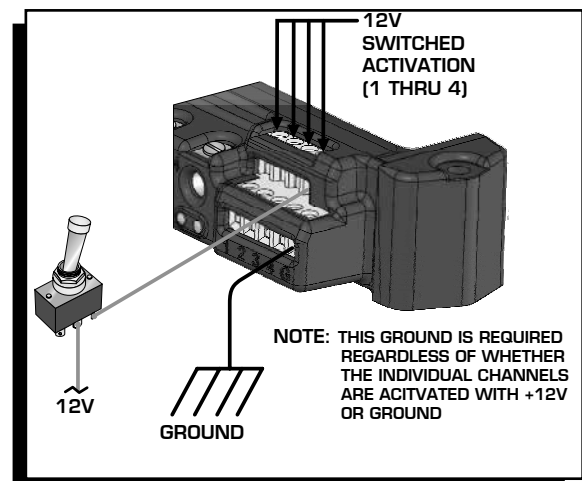

**Figure 3 12V Activation.**

A Loctite® Threadlocker 242® packet is included to fasten all threaded screws. It will penetrate the thread grooves, and bond within 10 minutes. The medium strength bond can be broken with hand tools, if necessary.

Apply only a small amount of Loctite 242 onto the thread of each of the 5 screws. Do not apply too much Loctite.

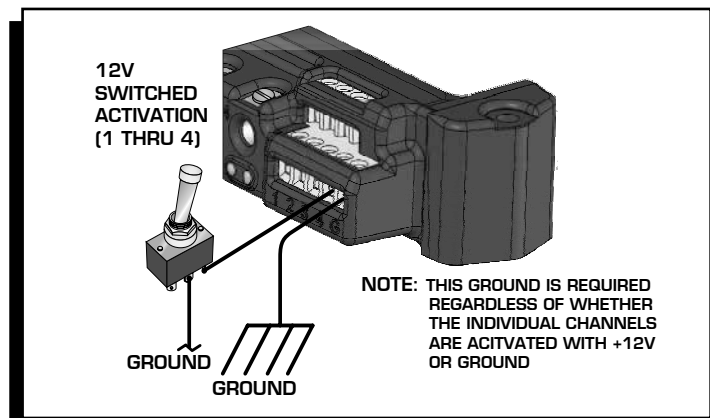

**Figure 4 Ground Activation.**

**LED INDICATORS**

Each relay branch has two diagnostic LEDs just below the corresponding terminal. The LEDs status can assist with diagnosing wiring problems, locating short circuits, or excessive current draws (Figure 5).

**Diagnostic:** Verify battery and ground connections. Deactivate/Reactivate the faulted channel(s) to reset.

LED			
Indicator	Left	Right	Status
○ ○	Off	Off	Normal 'Off'
● ●	On	On	Normal 'On'
● ○	On	Off	Fault - Output On <sup>1</sup>
○ ●	Off	On	Fault - Output Off <sup>2</sup>

Figure 5 Diagnostic LED Chart.

<sup>1</sup> Fault due to 12V applied directly to the output, or faulty unit.

<sup>2</sup> Fault due to over-current, missing BATT Power or Ground. Reset faulted channel(s) by deactivating/re-activating via applicable trigger wires(s).

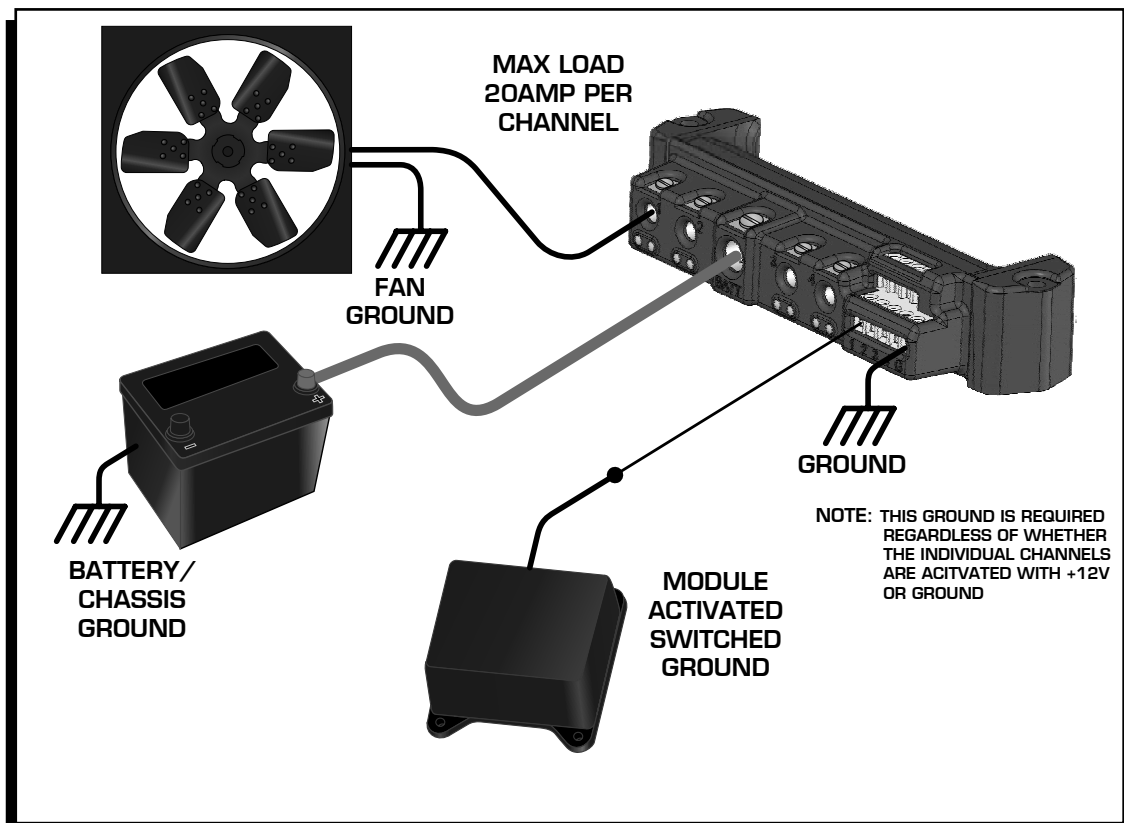

Figure 6 PN 7564 Typical Applications.

**Note:** Channels can be run in parallel for devices requiring more than 20A single-channel rating.

## TECH NOTES

---

---

---

---

---

---

---

---

---

---

---

---

---

---

---

---

---

---

---

---

---

---

---

### Service

In case of malfunction, this MSD component will be repaired free of charge according to the terms of the warranty. When returning MSD components for warranty service, **Proof of Purchase** must be supplied for verification. After the warranty period has expired, repair service is based on a minimum and maximum fee.

**All returns must have a Return Material Authorization (RMA) number** issued to them before being returned. To obtain an RMA number please contact MSD Customer Service at 1 (888) MSD-7859 or visit our website at [www.msdpower.com/rma](http://www.msdpower.com/rma) to automatically obtain a number and shipping information.

When returning the unit for repair, leave all wires at the length in which you have them installed. Be sure to include a detailed account of any problems experienced, and what components and accessories are installed on the vehicle. The repaired unit will be returned as soon as possible using Ground shipping methods (ground shipping is covered by warranty). For more information, call MSD at (915) 855-7123. MSD technicians are available from 7:00 a.m. to 5:00 p.m. Monday - Friday (mountain time).

### Limited Warranty

MSD warrants this product to be free from defects in material and workmanship under its intended normal use\*, when properly installed and purchased from an authorized MSD dealer, for a period of one year from the date of the original purchase. This warranty is void for any products purchased through auction websites. If found to be defective as mentioned above, it will be repaired or replaced at the option of MSD. Any item that is covered under this warranty will be returned free of charge using Ground shipping methods.

This shall constitute the sole remedy of the purchaser and the sole liability of MSD. To the extent permitted by law, the foregoing is exclusive and in lieu of all other warranties or representation whether expressed or implied, including any implied warranty of merchantability or fitness. In no event shall MSD or its suppliers be liable for special or consequential damages.

\*Intended normal use means that this item is being used as was originally intended and for the original application as sold by MSD. Any modifications to this item or if it is used on an application other than what MSD markets the product, the warranty will be void. It is the sole responsibility of the customer to determine that this item will work for the application they are intending. MSD will accept no liability for custom applications.