



# INSTALLATION INSTRUCTIONS

## MSD Blaster SC Coil PN 8235

**IMPORTANT:** Read the Instructions before attempting the installation.

### Parts Included:

- 1 - Blaster SC Coil, PN 8235
- 1 - Parts Bag and Mounting Hardware
- 1 - MSD 90° Boot and Terminal

### Components Required:

- 1 - SC Coil Driver, PN 6305
- 1 - Pro-Billet Honda Distributor, PN 8488

**WARNING:** During installation, disconnect the battery cables. When disconnecting the battery, always remove the Negative cable first and install it last.

**WARNING:** The Blaster SC Coil and Coil Driver produce very high voltage and current. Use caution during installation and while working near the Coil assembly.

The MSD Blaster SC Coil is designed to be used with the SC Coil Driver, PN 6305, and Pro-Billet Honda Distributor, PN 8488. An MSD SCI, 6-Series and 7-Series Ignition Control may also be used. The Blaster SC Coil cannot be used with factory ignition systems as a stand alone coil.

### COIL LOCATION AND MOUNTING

1. Find a suitable mounting location for the Coil and Driver assembly. It can be mounted in any position as long as it is away from direct engine heat sources. Also make sure that the Coil Driver wiring harness reaches the distributor.
2. Ensure that there is enough room to clear the Coil and the Coil Driver when they are assembled.
3. Use the Coil as a template and mark the mounting holes. Figure 1 also provides a template to assist in the mounting.
4. Use a 3/16" drill bit to make the mounting holes.

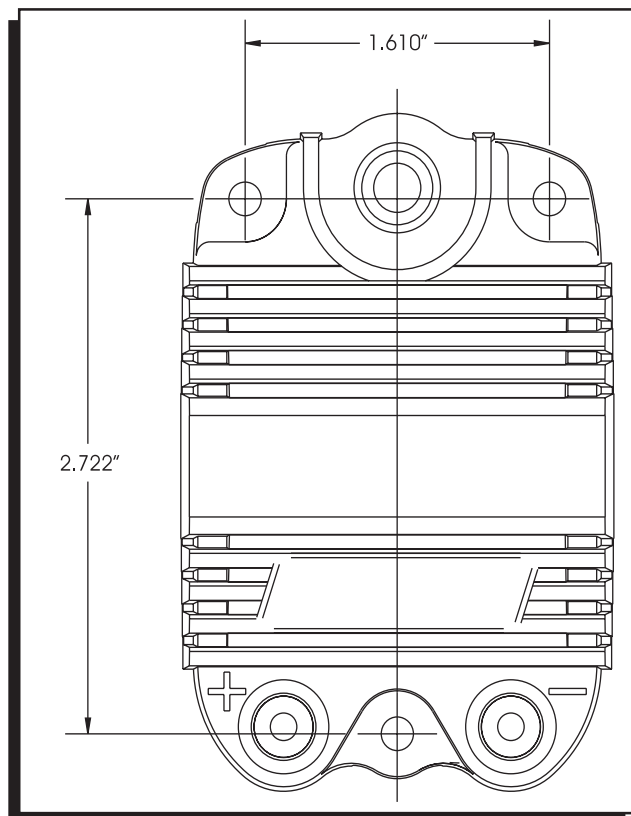

Figure 1 Coil Mounting Template.

## ASSEMBLE THE COIL AND DRIVER

1. Position the Coil Driver, PN 6305, under the Blaster SC Coil with the aluminum base facing down.
2. Install the long Phillips screws through the coil and into the supplied vibration mount at the base of the Coil Driver.
3. Mount the Coil/Driver assembly.

## WIRING

**Primary Wires:** The two primary wires, Red and Orange, are the only wires that connect to the coil. Orange connects to Coil Negative (-), Red connects to the Coil Positive (+) terminal. Install a lockwasher followed by the wire terminal with another lockwasher and the supplied Phillips screws.

**Distributor Connector:** Route the 4-pin Deutsch Connector to the mating connector on the distributor (Figure 3).

**Tachometer Output:** The Blue wire that is routed with the distributor connector provides a 12 volt square wave tachometer output signal. It can be used for aftermarket tachs, rpm switches and other accessories (Figure 3). Factory installed tachs will operate with the MSD system.

**Note:** Vehicles equipped with OEM tachometers do not require any special wiring for the tach to operate.

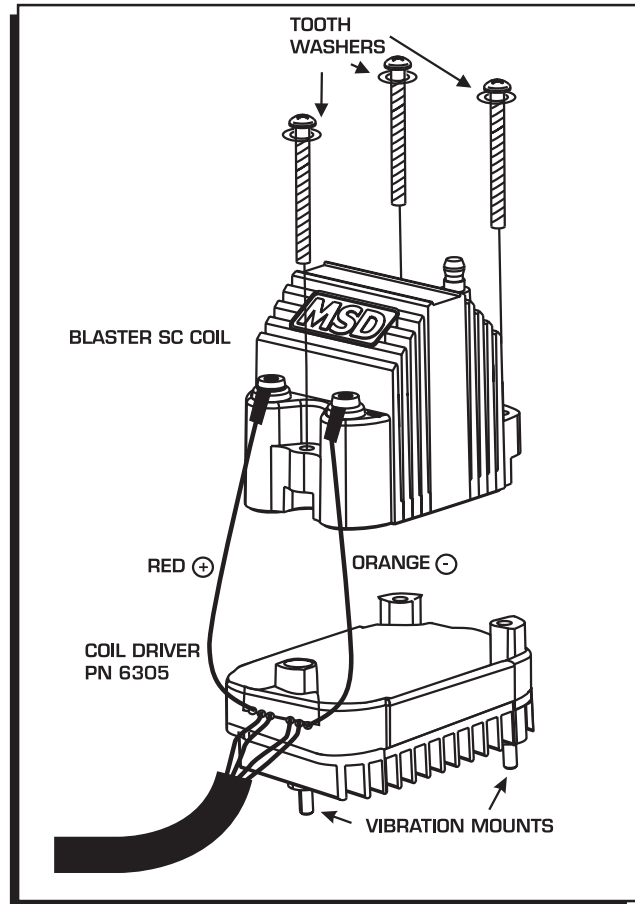

Figure 2 Assemble the Coil and Driver.

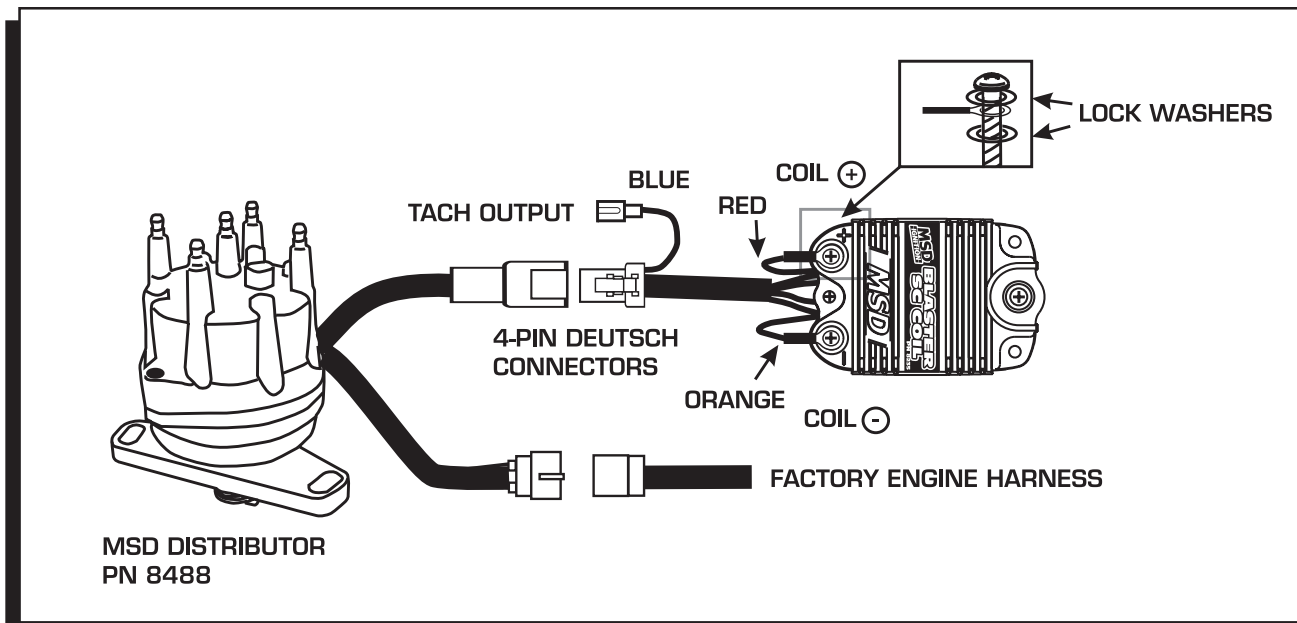

Figure 3 Wiring the Coil and Driver to the Distributor.



