

# MSD<sup>™</sup> IGNITION INSTALLATION INSTRUCTIONS

## MSD Rotor, PN 8423 Fits MSD Cap-A-Dapt, PN 8445, and PN 8441 also, MSD Distributors with Cap PN 8408

### Parts Included:

1 – Rotor, PN 8423

2 – 3/4" Phillips Head Screws

2 – 5/8" Phillips Head Screws

2 – Belleville Washers

**WARNING:** Disconnect the battery during installation. When disconnecting the battery, always remove the negative cable first and install it last.

**IMPORTANT:** There are two different length screws supplied with this rotor. It is important to determine which screws are correct for your application due to clearance of the magnetic pickup.

Remove the cap, rotor and the cap spacer and note the rotor screw retainer that is installed on the bottom of the advance plate (Figure 1). There are two styles used; one is a Screw Retainer, the other is a Retainer with a Nut. The Retainer accepts the shorter 5/8" screw while the Nut version accepts the 3/4" screw.

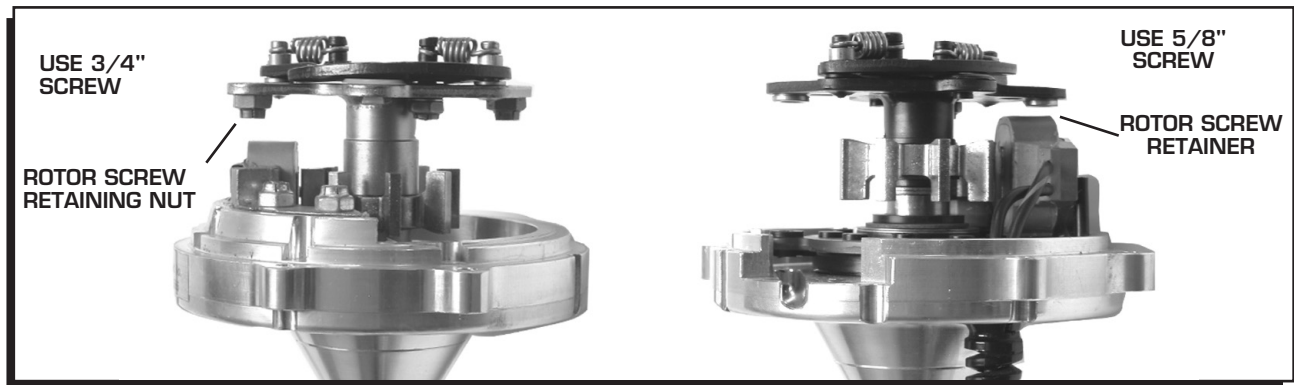

Figure 1 Determining Rotor Screw Length.

**NOTE:** IT IS RECOMMENDED TO INSTALL THE ROTOR AND CHECK THE CLEARANCE BEFORE REASSEMBLING THE DISTRIBUTOR.

Once the rotor screw length is determined, install the rotor being sure the round and square aligning pegs are lined up correctly. Install the Belleville washers with the **dome facing up** on the screws and tighten the rotor (Figure 2). Install the cap and plug wires.

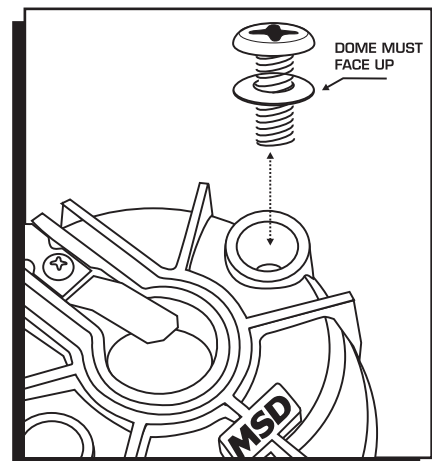

Figure 2 Washer Installation.



# INSTALLATION INSTRUCTIONS

## Service

In case of malfunction, this MSD component will be repaired free of charge according to the terms of the warranty. When returning MSD components for service, Proof of Purchase must be supplied for warranty verification. After the warranty period has expired, repair service is charged based on a minimum and maximum charge.

Send the unit prepaid with proof of purchase to the attention of: **Customer Service Department, Autotronic Controls Corporation, 12120 Esther Lama, Suite 114, El Paso, Texas 79936.**

When returning the unit for repair, leave all wires at the length in which you have them installed. Be sure to include a detailed account of any problems experienced, and what components and accessories are installed on the vehicle.

The repaired unit will be returned as soon as possible after receipt, COD for any charges. (Ground shipping is covered by warranty). All units are returned regular UPS unless otherwise noted. For more information, call the MSD Customer Service Line (915) 855-7123. MSD technicians are available from 8:00 a.m. to 5:00 p.m. Monday - Friday (Mountain Time).

## Limited Warranty

Autotronic Controls Corporation warrants MSD Ignition products to be free from defects in material and workmanship under normal use and if properly installed for a period of one year from date of purchase. If found to be defective as mentioned above, it will be replaced or repaired if returned prepaid along with proof of date of purchase. This shall constitute the sole remedy of the purchaser and the sole liability of Autotronic Controls Corporation. To the extent permitted by law, the foregoing is exclusive and in lieu of all other warranties or representations whether expressed or implied, including any implied warranty of merchantability or fitness. In no event shall Autotronic Controls Corporation be liable for special or consequential damages.