

INSTALLATION INSTRUCTIONS
MSD DISTRIBUTOR CAP, PN 8433**Parts Included:**

1 - Cap, PN 8433
2 - 10-32x1.25" Hex Screws

1 - Wire Retainer
2 - 1.5" Phillips Head Screws

Note: If you need to adapt your spark plug wire boots and terminals to fit the towers of the PN 8433 Cap, MSD offers a kit of nine boots and terminals, PN 8849.

The PN 8433 Cap fits all of the MSD Distributors that use the GM Socket style cap (MSD PN 8437). It will also fit GM Distributors that use a "window" style cap.

Before installing the new cap, note the location of the spark plug wires. It is a good idea to mark the location of one wire before removing it while leaving the other wires connected to the old cap. Then, with the new cap installed, you can install each wire individually avoiding any confusion.

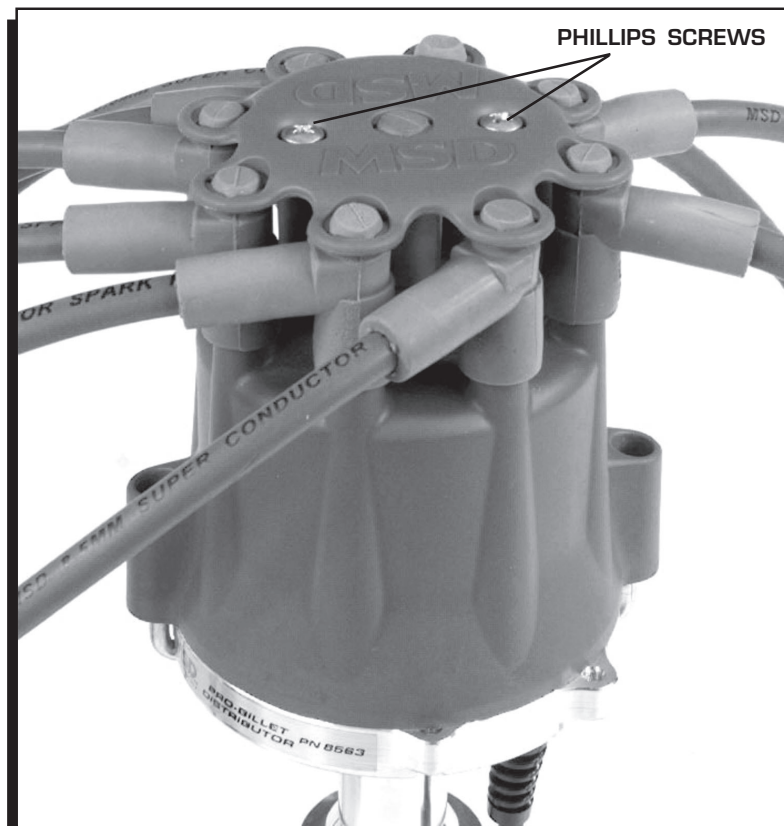

Figure 1 Installing the Wire Retainer.

After installing the spark plug wires, position the retainer over the boots. Align the mounting bosses and use the supplied 1.5" self-tapping Phillips head screws to hold the retainer in place. It may be necessary to apply a slight amount of lubricant to the boots to help them seat into the retainer properly.

Installation Option: This Cap can also be bolted down to an MSD Pro-Billet or Billet Distributor base with the supplied hardware. To accomplish this, the spring clips must be cut off (Figure 2).

Note: When the cap is bolted down, the location of the spark plug wires must be changed.

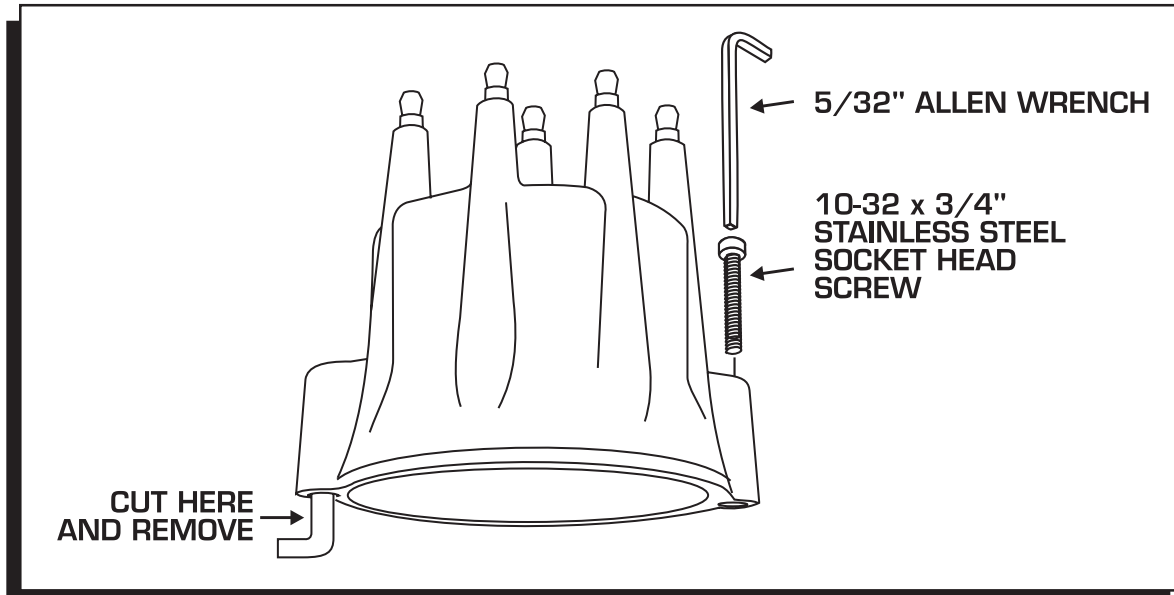

Figure 2 Optional Installation by Bolting the Cap Down.

Service

In case of malfunction, this MSD component will be repaired free of charge according to the terms of the warranty. When returning MSD components for service, Proof of Purchase must be supplied for warranty verification. After the warranty period has expired, repair service is charged based on a minimum and maximum charge.

Send the unit prepaid with proof of purchase to the attention of: **Customer Service Department, Autotronic Controls Corporation, 12120 Esther Lama, Suite 114, El Paso, Texas 79936.**

Be sure to include a detailed account of any problems experienced, and what components and accessories are installed on the vehicle.

The repaired unit will be returned as soon as possible after receipt, COD for any charges. (Ground shipping is covered by warranty). All units are returned regular UPS unless otherwise noted. For more information, call the MSD Customer Service Line (915) 855-7123. MSD technicians are available from 8:00 a.m. to 5:00 p.m. Monday - Friday (mountain time).

Limited Warranty

Autotronic Controls Corporation warrants MSD Ignition products to be free from defects in material and workmanship under normal use and if properly installed for a period of one year from date of purchase. If found to be defective as mentioned above, it will be replaced or repaired if returned prepaid along with proof of date of purchase. This shall constitute the sole remedy of the purchaser and the sole liability of Autotronic Controls Corporation. To the extent permitted by law, the foregoing is exclusive and in lieu of all other warranties or representations whether expressed or implied, including any implied warranty of merchantability or fitness. In no event shall Autotronic Controls Corporation be liable for special or consequential damages.