

**VACUUM ADVANCE LOCKOUT  
PN 8468**

If you do not want to use the vacuum advance canister of the MSD Distributor, MSD has supplied the distributor with a lockout mechanism. The Lockout bolts in the position of the vacuum canister and will hold the pickup assembly firmly in place. The installation is easiest with the distributor out of the engine.

1. Remove the two Allen head screws that hold the advance canister (Figure 1).
2. Remove the snap ring that holds the magnetic pickup assembly in place. This is easy to do with a set of snap ring pliers by straddling one of the reluctor paddles.
3. Gently lift up on the mag pickup plate and slide the vacuum canister out.
4. Install the Lockout Plate in place of the canister. Install the two retaining screws but do not tighten at this time.
5. Install the supplied self tapping screw and washer (continued)

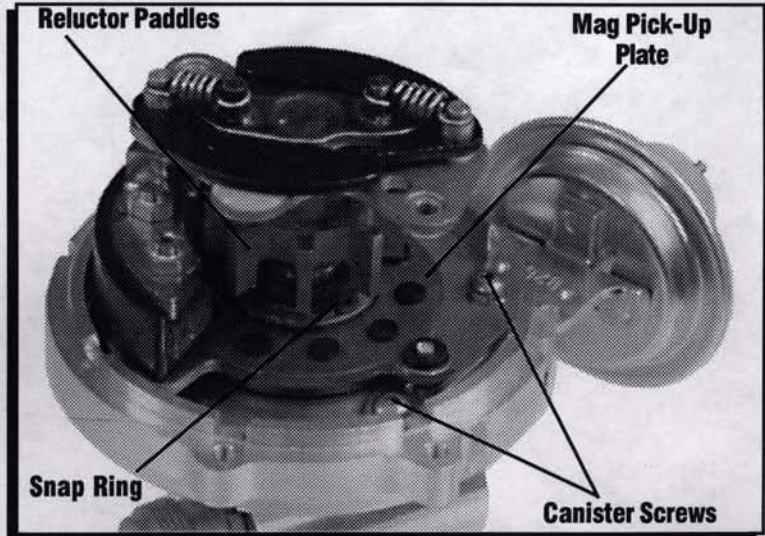

Figure 1 Removing the Vacuum Canister.

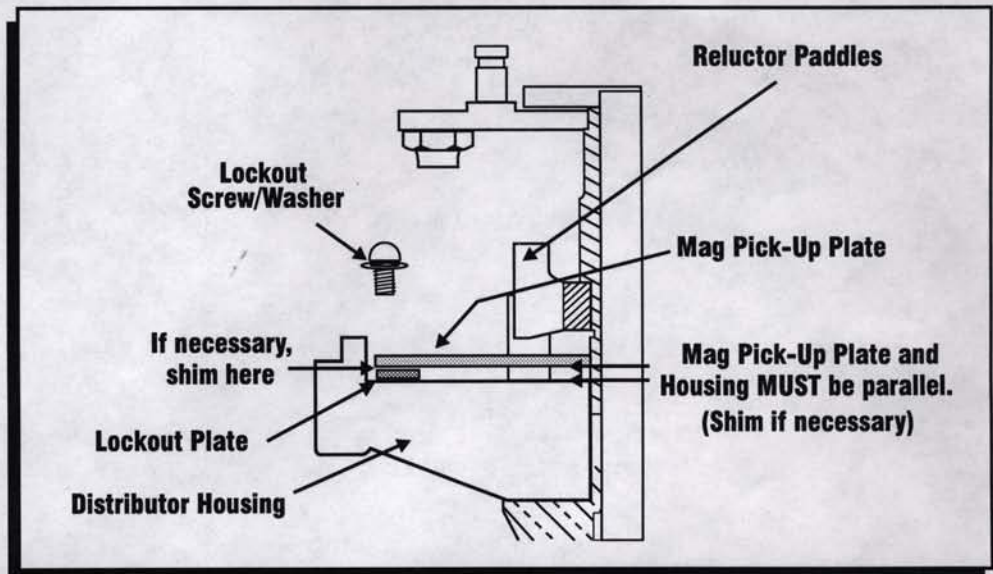

Figure 2 Checking Installation of the Lockout Plate.

through the Lockout and tighten. It is important to make sure the pickup plate is parallel with the housing of the distributor (Figure 2). If it is cocked or slanted, the paddles of the reluctor may contact the pickup. Check the clearance by rotating the distributor shaft. If necessary, use the supplied shims under the Lockout hold-down to correctly position the pickup plate.

**Note:** If no shims were required, use one beneath the washer of the Lock-Out Hold Down Screw.

6. After checking the reluctor to pickup clearance, tighten the Lockout retaining screws and install the snap ring.
7. Install the distributor, rotor and cap. Check the timing when complete.

**Note:** Do not forget to plug the original vacuum advance hose.

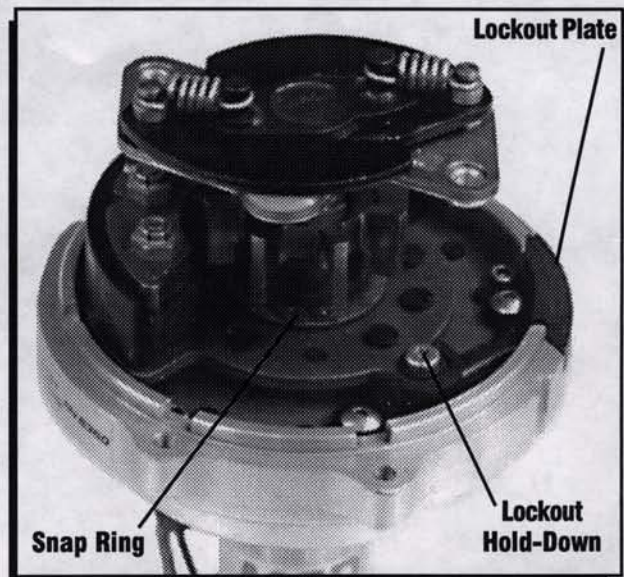

**Figure 3 Installation of the Vacuum Lockout Plate.**

### Service

In case of malfunction, this MSD component will be repaired free of charge according to the terms of the warranty. When returning MSD components for service, Proof of Purchase must be supplied for warranty verification. After the warranty period has expired, repair service is charged based on a minimum and maximum charge.

Send the unit prepaid with proof of purchase to the attention of: **Customer Service Department, Autotronic Controls Corporation, 12120 Esther Lama, El Paso, Texas 79936.**

When returning the unit for repair, leave all wires at the length in which you have them installed. Cutting wires close to the unit will void your warranty. Be sure to include a detailed account of any problems experienced, and what components and accessories are installed on the vehicle.

The repaired unit will be returned as soon as possible after receipt, COD for any charges. For more information, call the MSD Customer Service Line (915) 855-7123. MSD technicians are available from 8:00 a.m. to 5:00 p.m. Monday - Friday (mountain time).