

MSD[®] IGNITION

INSTALLATION INSTRUCTIONS

MSD Timing Light

PN 8990

Parts Included:

- 1 - MSD Timing Light
- 1 - Cable Harness

Note: Consult a service manual for your vehicle for information on vacuum connections and specific timing procedures.

CONNECTING THE MSD TIMING LIGHT

1. Plug the 4-pin connector on the cable harness into the receptacle on the bottom of the timing light. Note that it will only plug in one way.
2. With the engine off, connect the Black clip to the negative (-) terminal on the battery. Connect the Red clip to the positive (+) terminal on the battery or to the main power wire on the alternator (Figure 1).
3. Clamp the inductive pickup over the number 1 spark plug wire (See Figure 1). The position of the inductive pickup does not matter but the wire must fit in the gap between the jaws of the pickup (Figure 2). Do not pinch the wire between the end of the jaws. Consult your vehicle's service manual to locate the number 1 cylinder on your engine.

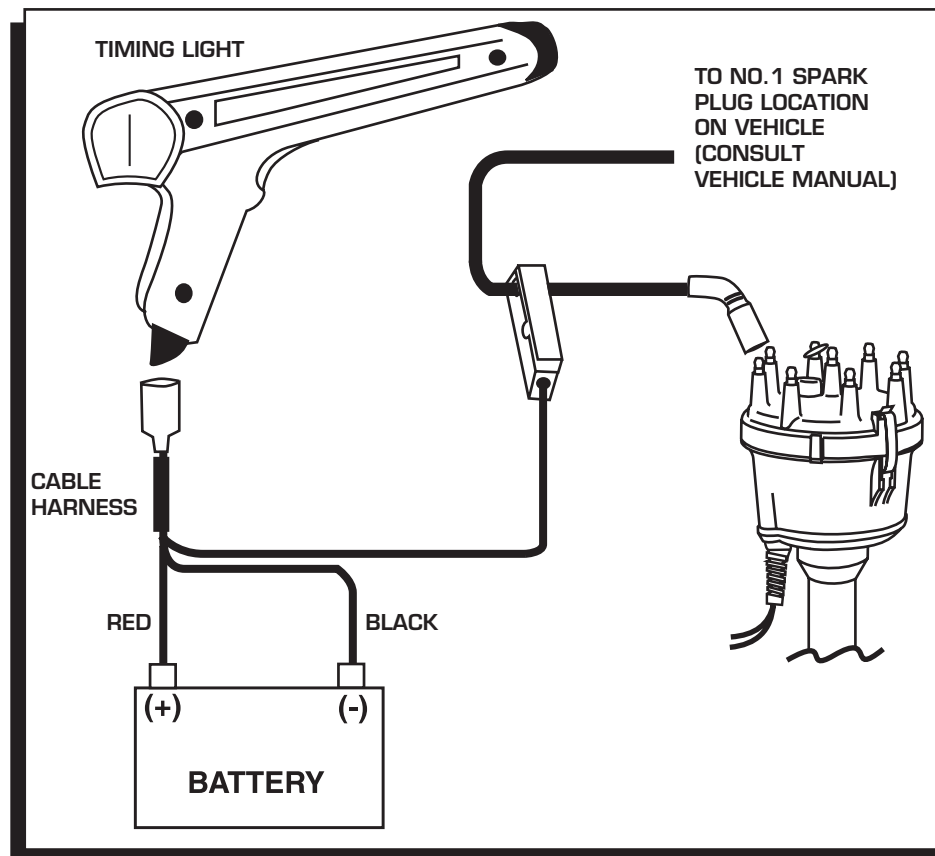

Figure 1 Wiring.

Note: The ferrite pole pieces in the inductive pickup are fragile and may be damaged if the jaws are allowed to "snap" closed or if the pickup itself is dropped.

4. With the engine stopped, clean any dirt from the timing marks. Figure 3 shows several typical timing marks and the rotation of the engine.
5. Set the engine idle speed according to the service manual using a tachometer.
6. If the distributor has breaker points, set the dwell angle according to the service manual before checking engine timing. (When using an MSD Ignition, the dwell setting is not critical.)

CHECKING THE ENGINE TIMING

Caution: When timing the engine, be very careful not to let the Timing Light cables get tangled in the engine's cooling fan.

1. Start the engine and let it warm up to operating temperature.
2. With the engine idling at the recommended rpm, aim the Timing Light at the timing marks and press the trigger switch to operate the light. The engine timing should be the same as recommended in the service manual. If not, see the next section on adjusting the timing.

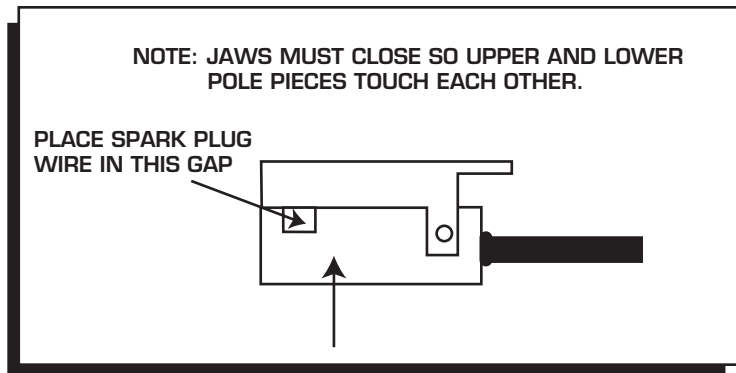

Figure 2 Inductive Pickup.

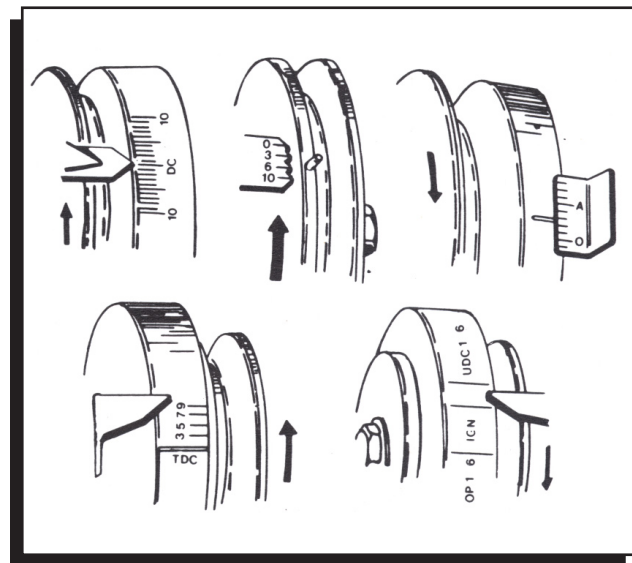

Figure 3 Typical Engine Timing Marks.

ADJUSTING THE ENGINE TIMING

STANDARD POINTS OR ELECTRONIC DISTRIBUTORS

1. Stop the engine. Loosen the distributor hold-down clamp until the distributor is just loose enough to turn by hand.
2. Restart the engine. Using the Timing light, rotate the distributor until the timing marks line up. Stop the engine and securely tighten the distributor hold-down clamp.
3. Restart the engine and recheck the timing. If the timing needs further adjustment, repeat.

CRANK TRIGGER SYSTEMS

1. Stop the engine. Loosen the timing pickup and adjust it in the bracket, depending on whether you want to advance or retard the timing. Tighten the pickup.

Caution: Do not attempt to move the pickup while the engine is running. Personal injury or damage to the timing pickup could result.

2. Restart the engine and recheck the timing. If the timing needs further adjustment, repeat step.

TIMING TIPS

- In many racing applications, the timing should be checked at a higher rpm to verify total advance. In this case, a new mark must be made on the harmonic balancer representing your desired total advance (i.e. BTDC). This can be done using a timing tape or a degree wheel. After you've made the mark, start the engine and increase the rpm high enough to where all the mechanical advance is in. When your new mark lines up with the timing marks, you are at your selected total timing.
- Make sure the power clips are securely attached to the battery or alternator. Do not connect these to the coil.
- Keep the Timing Lights power cables away from all the spark plug wires.
- Make sure the number 1 cylinder wire is well separated from the other spark plug wires. This minimizes the chance for stray signals causing inaccurate readings.
- Make sure the wires to the inductive pickup do not pass near any spark plug wires. Again, this will help prevent false triggering of the light.
- Keep the pole pieces clean by wiping them with a cloth. Do not scrape or file the pole pieces. To insure accurate readings, make sure the number 1 wire is widely separated from the other spark plug wires.
- Always use the same timing light when tuning. This will keep your timing settings consistent.

