

Installation Instructions for
70396
TRANSMISSION PAN
FITS: GM 2015+ TRUCKS AND SUV'S
WITH 8L90E TRANSMISSIONS

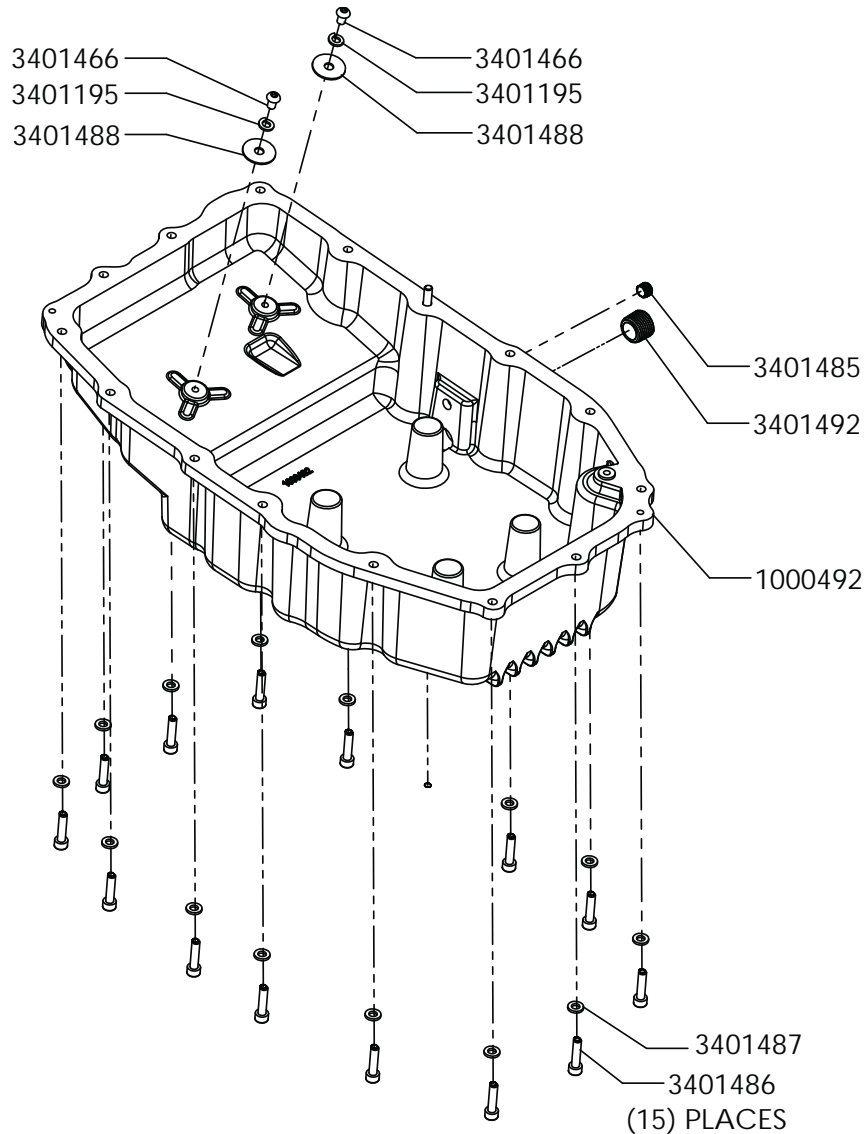

PART NO.	DESCRIPTION	QTY.
1000492-88	8L90 GM Trucks Deep Pan	1
70396BA-01	Hardware Pack	1
3401486	M6-1.0x25MM Srew	15
3401487	M6 Flat Washer	15
3401195	M6 Lock Washer	2
3401466	M6 x 10MM Screw	2
3401488	1/4" Oversized Flat Washer	2
3401492	1/2 NPTF Socket Plug	1
3401485	1/8 NPT Pipe Bolt	1

PRODUCT OVERVIEW:

Thank you for purchasing B&M 70396 Transmission Pan. This kit is designed to work with 8L90E transmissions. Be sure to acquire the factory fill procedure, which varies between specific models, prior to beginning project.

B&M also offers the following related products:

Transmission Oil Cooler (70255): We recommend a transmission oil cooler as a further safeguard against overheating.

Transmission Dipstick (22173): Add a remote dipstick to accurately measure your transmission fluid level.

Temperature Gauge (80212): Add a gauge to monitor your transmission fluid temperature.



1. Please take a moment to read and understand these instructions before installing your purchased performance kit. Use the parts drawing and list to verify kit contents.

REMOVE FACTORY TRANSMISSION PAN:

WARNINGS:

- Automatic transmissions operate at temperatures between 150° and 250°. To avoid burns from hot oil and parts, allow vehicle to cool off for a few hours before beginning installation.
- Maintain clean working surface as transmission components are precision fit so any dirt will directly impact success of installation.
- Vehicle must be level for stability and to obtain an accurate fluid level.

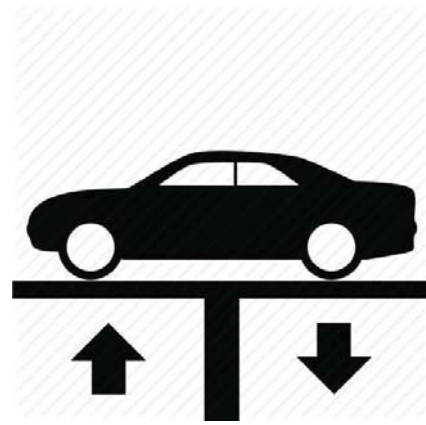

2. Raise vehicle up on a hoist or rack to working height. If you don't have access to a hoist or rack, raise vehicle and support securely with jack stands. Verify your vehicle will not move as you complete installation of your performance product.

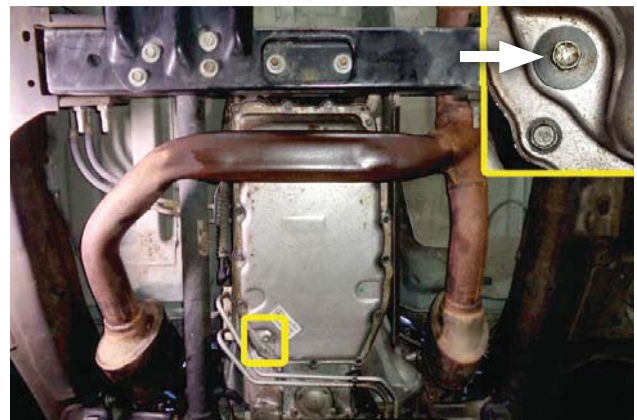

3. Place drain pan under transmission. Remove then wipe check bolt, while draining fluid from pan.

NOTE: Draining fluid through check bolt opening will only partially drain transmission pan. Be aware of remaining fluid leaking out as you finish removing pan.



4. Remove bolts (x3) and side cover from passenger side of transmission. Retain for later re-use.

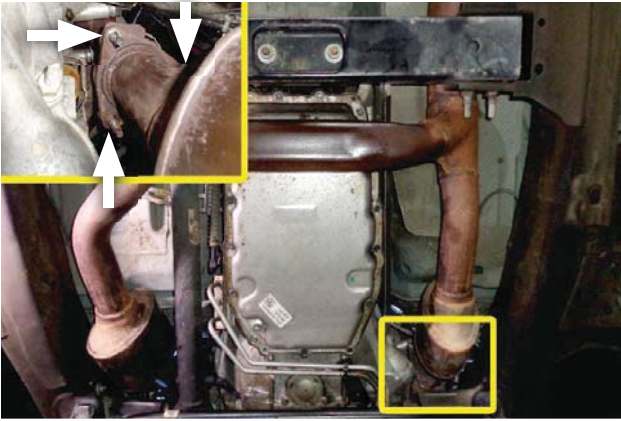

5. Remove nuts (x3) securing driver side exhaust manifold to exhaust pipe.

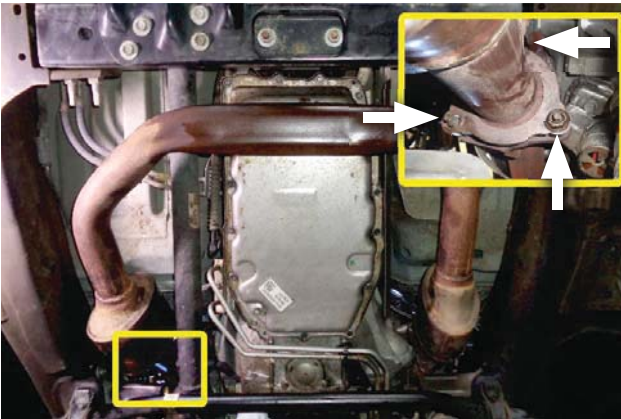

6. Remove nuts (x3) securing passenger side exhaust manifold.

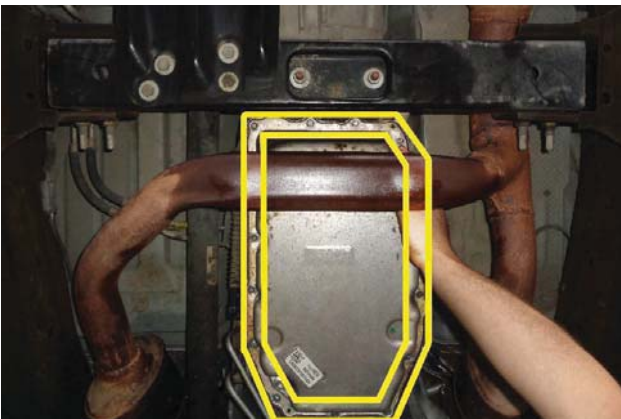

7. Pull passenger and driver side headers from their mounts.



NOTE: Remove bolts starting from front of pan then moving laterally towards back to direct remaining fluid into drain pan.

8. Remove bolts (x16) transmission pan to mount.

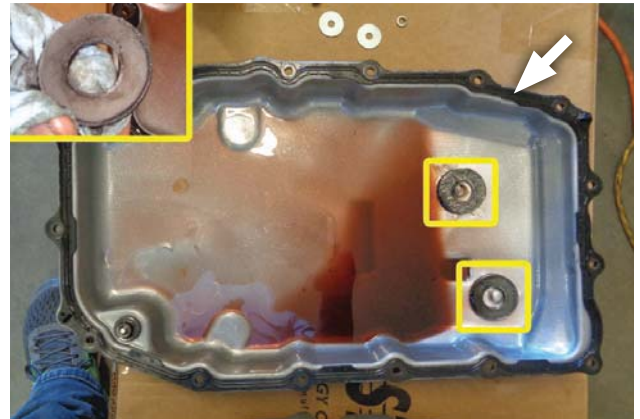

9. Remove magnets and gasket from transmission pan. Wipe them off and retain them for re-use.

ASSEMBLE AND INSTALL FLOWMASTER PERFORMANCE TRANSMISSION PAN:

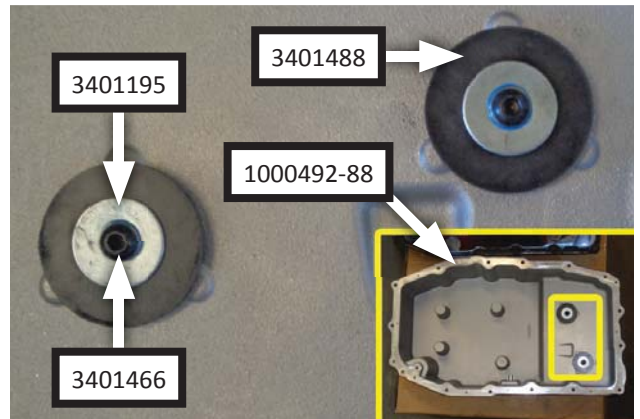

10. Apply loktite onto threads of 10mm screws (x2) (3401466) then install them through lock washers (x2) (3401195) and oversized flat washers (x2) (3401488) into deep pan (1000492-88) to secure factory magnets.



11. This kit includes a 1/8 NPT port above drain plug that can be used for an optional transmission temperature gauge. (available separately) Otherwise, install pipe plug (3401485) in port.

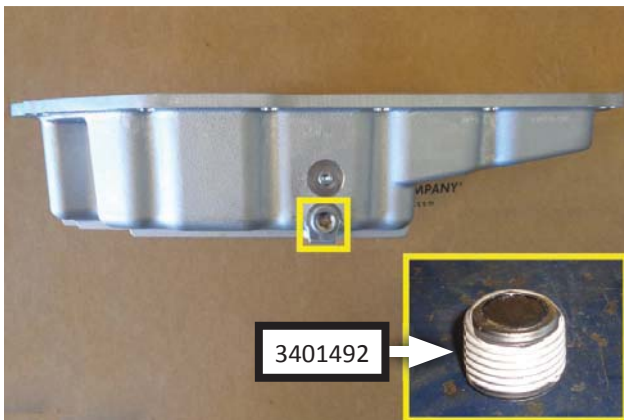

12. Apply Teflon tape to socket plug (3401492) before installing it into deep pan.

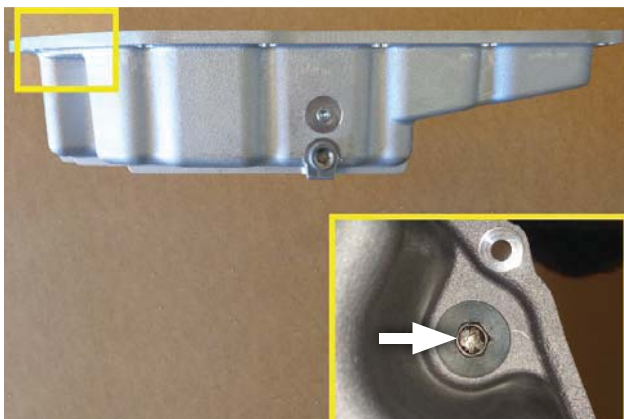

13. Install check bolt (removed step 3) into deep pan.



14. Inspect gasket (removed step 9) for flattened ridges or compressed edges then install it onto deep pan.

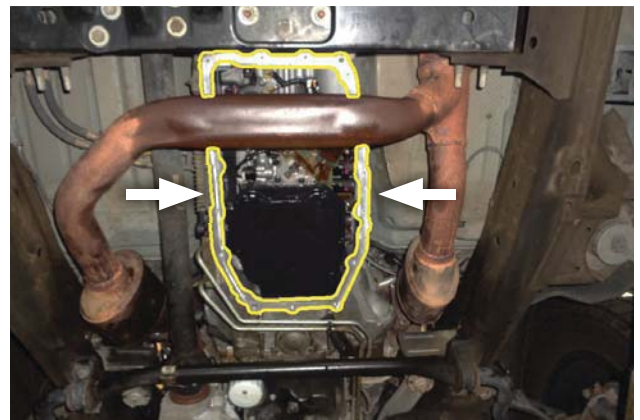

15. Use lint free rag to clean transmission pan mounting surface.

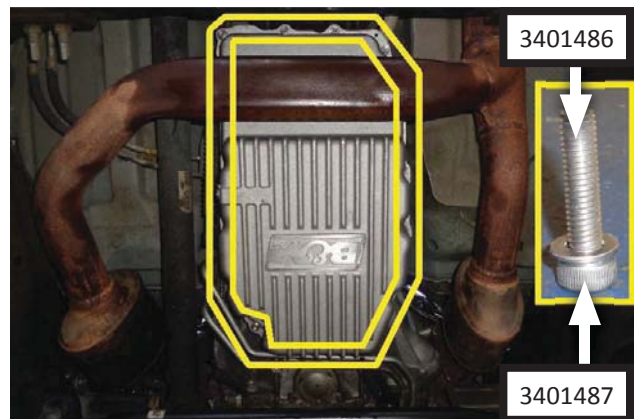

16. Install deep pan with 25MM screws (x15) (3401486) and flat washers (x15) (3401487) hand-tight. Then torque screws to 8ft lbs.



17. If you have chosen to purchase a dipstick; fill your transmission fluid according to vehicle manufacturers procedure, which may be available through vehicle owners manual, dealers service department or website.

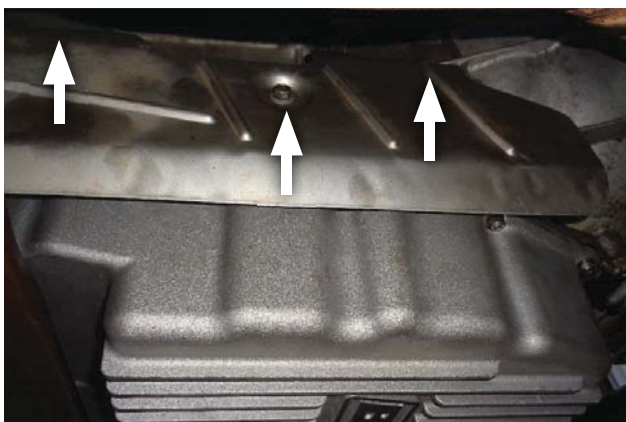

18. Re-install side cover with bolts (removed step 4) onto passenger side of transmission.



Congratulations, the installation of your Flowmaster performance Transmission Pan is now complete!

MONITORING TRANSMISSION:

To accurately monitor your transmission fluid level, it is important to always follow the same procedure when checking it:

- Check transmission fluid level at operating temperature. If necessary, drive vehicle for 10-15 minutes to bring transmission up to temperature.
- Park on level ground. With vehicle running at idle, slowly move gear shift level from PARK down through entire gear range, then back to PARK again, stopping for a few seconds at each gear position. With transmission in PARK, leave vehicle running at idle.
- Remove dipstick, wipe it off and reinstall it (with knob fully hand tight). Then remove dipstick again to check fluid level.

NOTE: B&M Racing maintain a highly trained technical service department to answer your technical questions, provide additional product information and offer various recommendations.

Technical Service: (707) 544-4761
Monday – Friday: 7:30 am to 5:00 pm Pacific Time
(Closed Saturday and Sunday)

MAIN OFFICE:

100 Stony Point RD., Suite 125
Santa Rosa, CA 95401

