

banks

with Installation Instructions
Owner's Manual

Banks Ram-Air® Intake System

2007-2009 Jeep 3.8L

THIS MANUAL IS FOR USE WITH KIT 41832

Gale Banks Engineering
546 Duggan Avenue • Azusa, CA 91702
(626) 969-9600 • Fax (626) 334-1743

Product Information & Sales: (888) 635-4565

bankspower.com

banks

General Installation Practices

Dear Customer,

If you have any questions concerning the installation of your Banks Ram-Air System, please call our Technical Service Hotline at (888) 839-2700 between 7:00 am and 5:00 pm (PT). If you have any questions relating to shipping or billing, please contact our Customer Service Department at (888) 839-5600.

Thank you.

1. For ease of installation of your Banks Ram-air intake system, familiarize yourself with the procedure by reading the entire manual before starting work. This manual contains 16 pages of copy, illustrations and parts listing. If any pages are missing from this manual please call Gale Banks Engineering immediately for a replacement.

2. The exploded view of the Ram-Air assembly (pages 4-5) provides only general guidance. Refer to each step and section diagram in this manual for proper instruction.

3. Throughout this manual, the left side of the vehicle refers to the driver's side, and the right-side to the passenger's side.

4. Disconnect the ground cable from the battery before beginning work. If there are two batteries, disconnect both.

5. Route and tie wires and hoses a minimum of 6 inches away from exhaust heat, moving parts and sharp edges. Clearance of 8 inches or more is recommended where possible.

6. During installation, keep the work area clean. If foreign debris is transferred to any Banks system component, clean it thoroughly before installing.

7. When raising the vehicle, support it on properly weight-rated safety stands, ramps or a commercial hoist. Follow the manufacturer's safety precautions. Take care to balance the vehicle to prevent it from slipping or falling. When using ramps, be sure the front wheels are centered squarely on the topsides; put the transmission in park; set the parking brake; and place blocks behind the rear wheels.

Caution! Do not use floor jacks to support the vehicle while working under it. Do not raise the vehicle onto concrete blocks, masonry or any other item not intended specifically for this use.

Notification

The Banks Ram-Air Filter comes pre-oiled and no oiling is necessary for initial installation. Service the filter as specified in the Filter Maintenance Section of this manual.

Tools Required:

- 10mm socket wrench
- Standard head screwdriver
- Standard pliers
- 5/16 in nut driver
- Clean shop towels or rags

Table of Contents

Section 1	4
General Assembly	
Section 2	6
Ram-Air Installation	
Section 3	10
Filter Maintenance	

Section 1

GENERAL ASSEMBLY

Figure 1

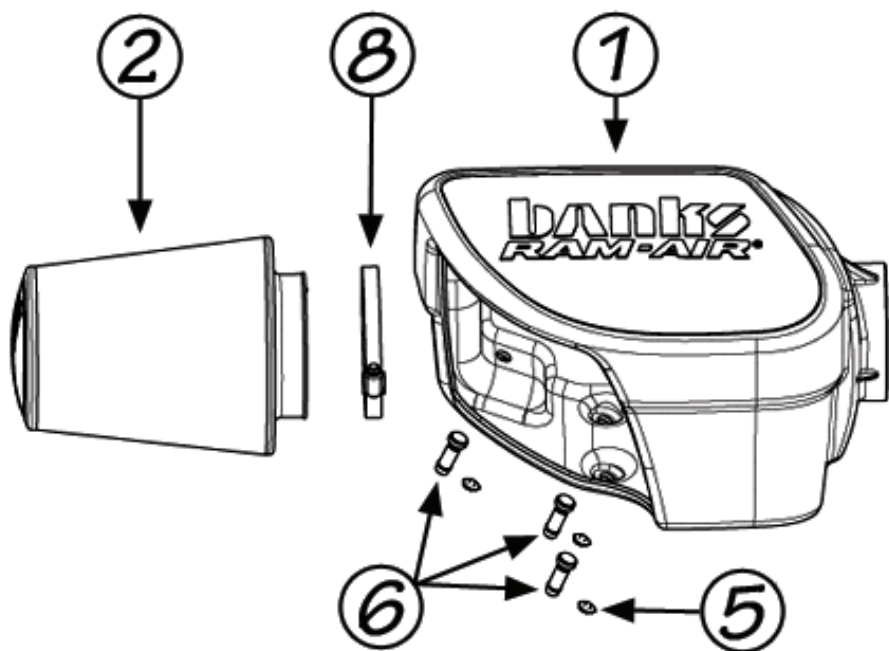

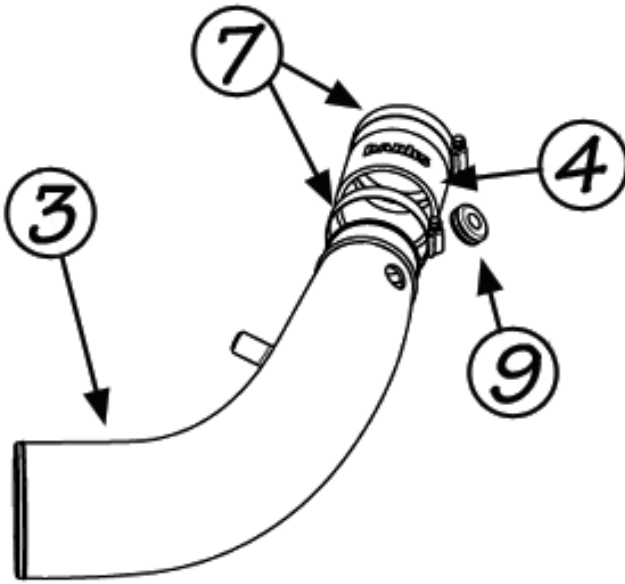

Bill of Materials

P/N	Item	Description	QTY
41833	1	Housing, Ram-Air Filter	1
41835	2	Air Filter Element, Ram-Air System	1
41836	3	Intake Tube, Ram-Air	1
94305	4	Hose, Throttle Body	1
91701	5	E-Clip, 3/8"	3
92152	6	Mounting Peg, A/F Housing	3
92853	7	Hose Clamp, #52 W/Liner	2
92872	8	Hose Clamp, #72 W/Liner	1
93652	9	Grommet, Temp Sensor	1

Section 2

RAM-AIR INSTALLATION

Use the Bill of Materials Chart and the General Assembly Drawing to reference component nomenclature and location. Use caution when working in the engine compartment. Make sure the engine has been OFF for several hours and cool.

You are about to install the Banks Ram-Air Intake System. Read and follow all steps before working on the vehicle. Some components from the stock air intake system will remain in service. Take care when removing stock air intake components to not damage them.

1. Disconnect and remove the Air Intake Temperature (AIT) Sensor located on the intake tube by moving the red tab back and pulling the connector. Set connector aside and retain sensor for re-use. See **Figure 2**.

Note: Take care when handling the sensor.

2. Disconnect the CCV hose from the air intake tube by moving spring clamp away from joint. Retain for re-use.

3. Loosen both air intake hose clamps and remove the air intake tube from the engine compartment. See **Figure 3**.

4. Un-clip the four tabs holding the air filter housing cover. Remove the cover and the air filter from the engine compartment and set aside.

5. Remove the air filter housing (bottom) by lifting up from the passenger side of the engine compartment and set aside. See **Figure 4**.

6. Install the 3 three (supplied) Mounting Pegs onto the Banks air filter housing so that they extend out of the housing and then attach the E-Clips onto the three Mounting Pegs from the outside of the housing. See **figure 5**.

Figure 2- Removal of AIT sensor

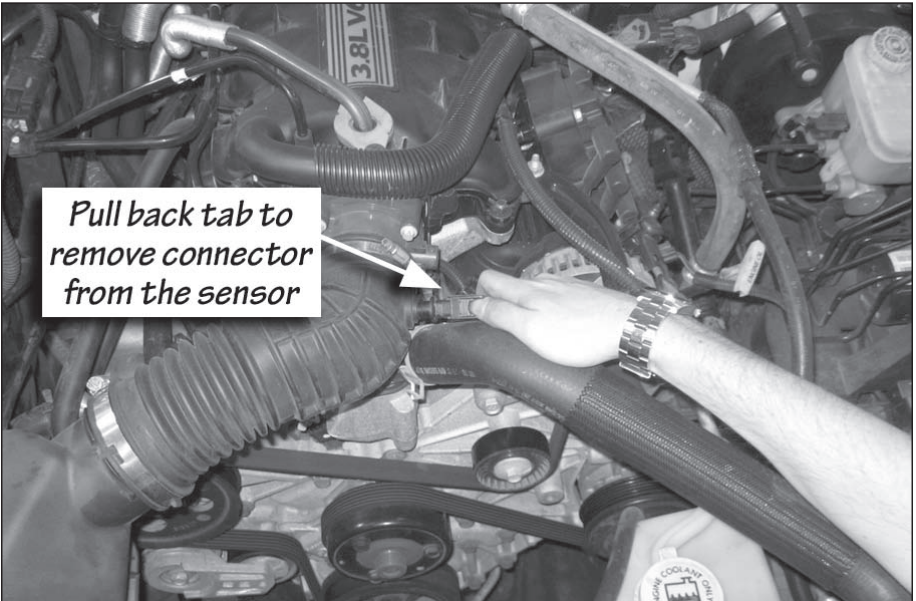

Figure 3- Loosening hose clamps for intake tube removal

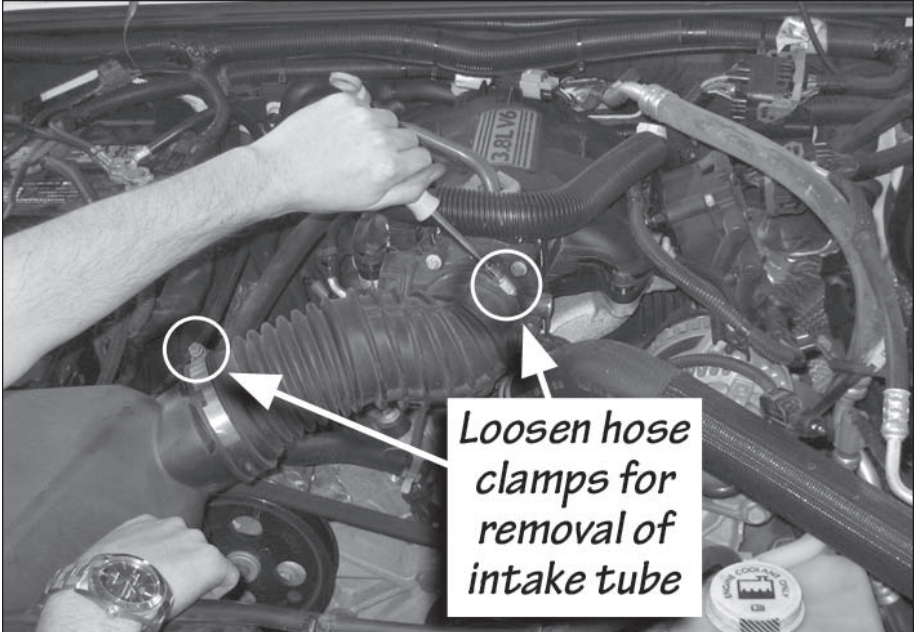

Figure 4- Removal of filter housing bottom

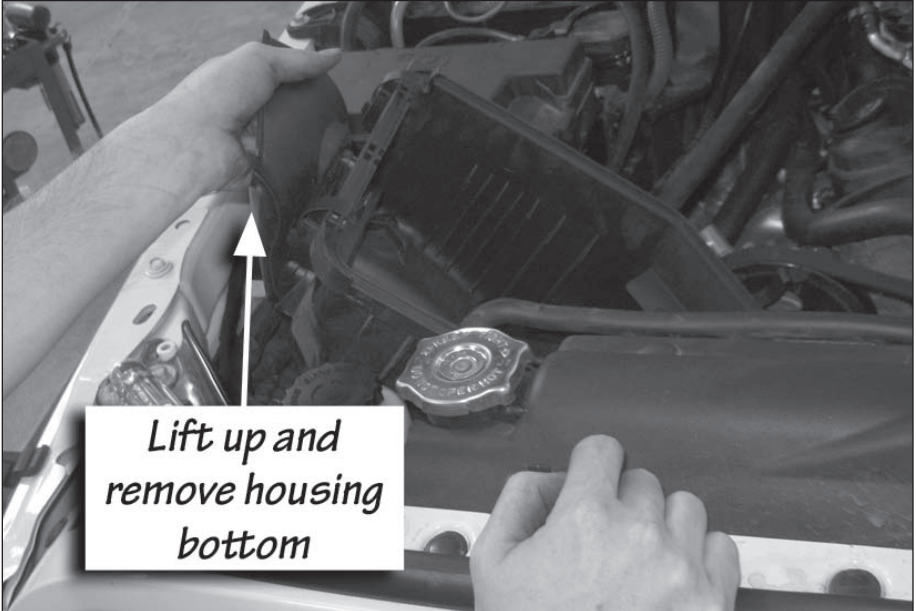
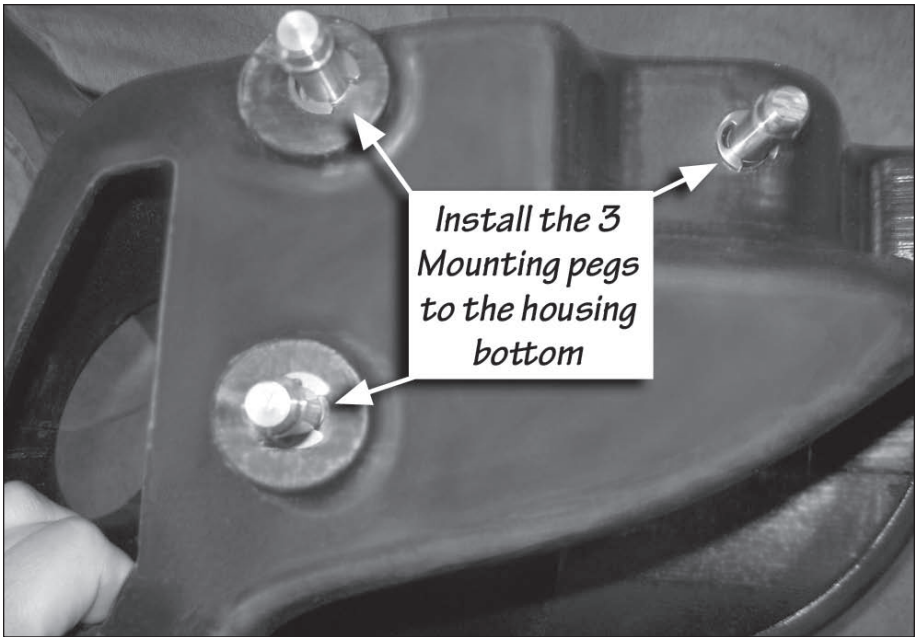

Figure 5- Attaching mounting pegs to the housing bottom



7. Locate the supplied filter hose clamp and install onto the Banks filter.

8. Locate the supplied rubber AIT grommet from your Banks kit and install onto the air intake tube.

9. Insert the Banks intake tube onto the Banks Ram-Air Housing; be sure to insert the end of the intake tube that has an arrow on it.

10. Insert the Banks air filter into the end of the Banks intake tube that is inside of the Banks Ram-Air Housing. For proper fit be sure that the arrows on the Banks air filter and intake tube line up. Tighten Banks filter hose clamp. See **Figure 6**.

11. Install the hose and two hose clamps onto the intake tube where it will attach to the throttle body.

12. Insert the Banks intake tube into the throttle body opening first. Then, Insert the three Banks air filter housing mounting pegs onto the stock grommets.

Note: Be sure that the mounting pegs have been properly inserted onto the grommets.

13. Tighten the two hose clamps that connect the Banks Ram-Air intake tube to the throttle body.

14. Install the AIT sensor flush into the grommet on the air intake tube. See **Figure 7**.

15. Re-Connect the Connector and the AIT sensor.

16. Re-Install the CCV vent hose connection to the Banks Ram-Air intake tube. Secure the connections by using stock spring clamps.

17. You have successfully completed the installation of the Banks Ram-Air Intake system. Make sure to go over all hose clamps for tightness and connectors for a sure fit. Make sure that the intake tube is not touching any engine components.

-END, SECTION 2-

Figure 6- Connecting air filter with intake tube

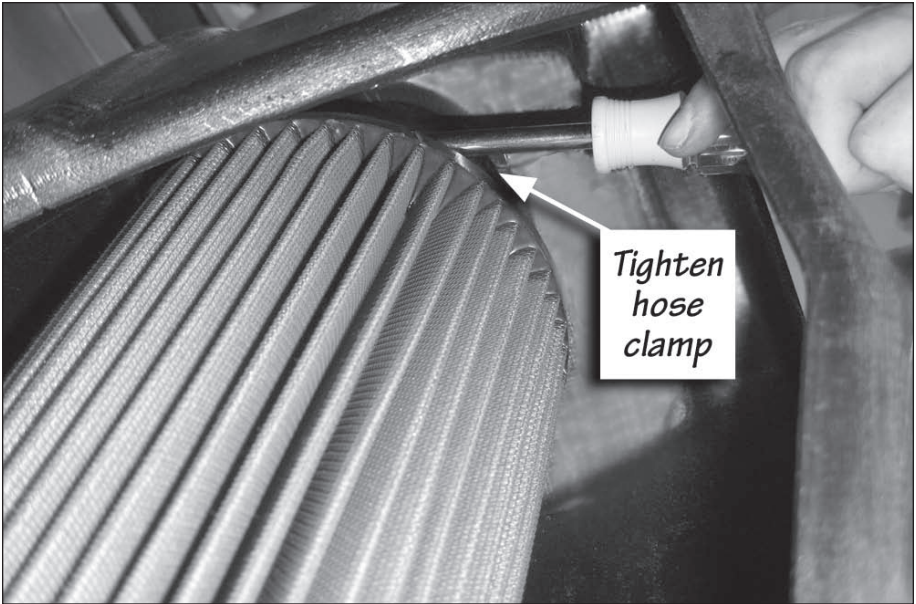
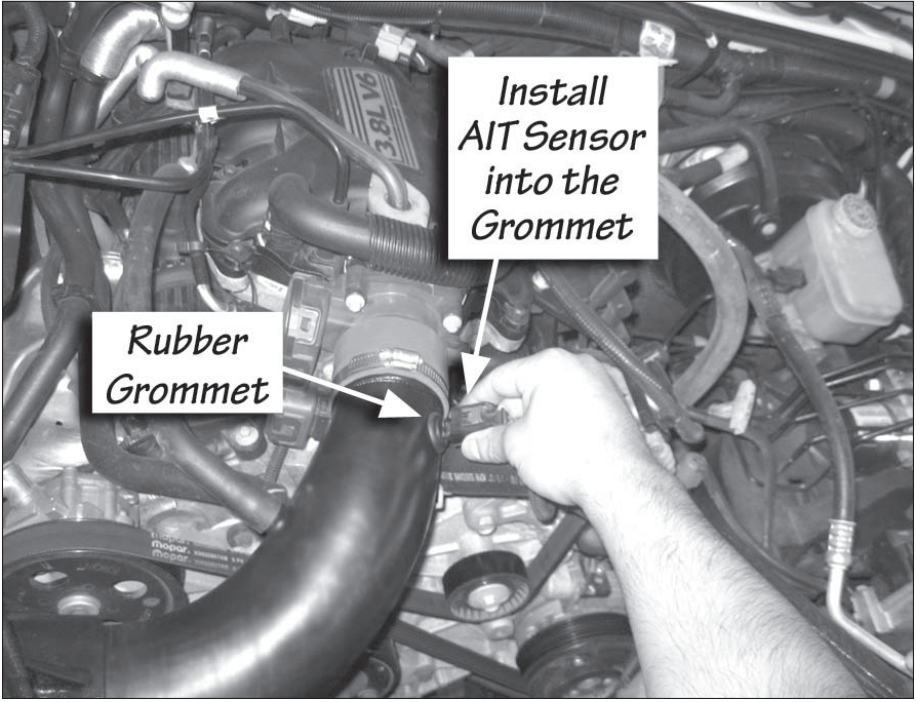

Figure 7- Re-Installation of AIT sensor



Section 3

FILTER MAINTENANCE

Notification

The Banks Ram-Air Filter comes pre-oiled and no oiling is necessary for initial installation. Service the filter as specified in steps 1-2.

1. Service Banks Ram Air Filter every 50-100,000 miles on street-driven applications. Service more often in off-road or heavy-dust conditions.

2. Use Banks Ram Air Filter cleaning system (part # 90094), available from Gale Banks Engineering to service the Air Filter. Follow the instructions included with the cleaning system to clean and re-oil your Banks Ram Air Filter. No gasoline cleaning, No steam cleaning, No caustic cleaning solutions, No strong detergents, No high pressure car wash, No parts cleaning solvents. Any of these No's can cause harm to the cotton filter media plus SHRINK and HARDEN the rubber end caps.

CAUTION! Extremely fine dust from agriculture or off-road use will pull the oil from the element. Frequent re-oiling of the element's clean side might be required. Completely service when practicable. For extra protection use an air-filter sealing grease on rubber ends of the element. Service only with Banks Ram-Air-filter cleaner and Banks Ram-Air-filter oil.

-END, SECTION 3-

Notes

Gale Banks Engineering
546 Duggan Avenue • Azusa, CA 91702
(626) 969-9600 • Fax (626) 334-1743

Product Information & Sales: (888) 635-4565

bankpower.com