



INSTALLATION INSTRUCTIONS

300 W PONTIAC WAY CLOVIS, CA 93612 local: 559-875-0222 fax: 559-876-2249 toll free: 800-445-3767

6446
5.5" REAR AXLE FLIP-KIT
2015+ FORD F-150 2WD SHORT BED

Thank you for being selective enough to choose our high quality BELLTECH PRODUCT. We have spent many hours developing our line of products so that you will receive maximum performance with minimum difficulty during installation.

- Note: Confirm that all of the hardware listed in the parts list (page 6) is in the kit. **DO NOT** begin installation if any part is missing. Read the instructions thoroughly before beginning this installation.
- Warning:** **DO NOT** work under a vehicle supported by only a jack. Place support stands securely under the vehicle in the manufacturer's specified locations unless otherwise instructed.
- Warning:** **DO NOT** drive vehicle until all work has been completed and checked. Torque all hardware to values specified.
- Reminder: Proper use of safety equipment and eye/face/hand protection is absolutely necessary when using these tools to perform procedures!
- Note: It is very helpful to have an assistant available during installation.

RECOMMENDED TOOLS:

- Properly rated floor jack and six (6) support stands
- Wheel chocks
- Metric socket set up to 27mm
- Metric combination wrench set up to 27mm
- Impact wrench
- C-clamps
- Power Drill
- Drill bit set
- Abrasive cutter
- Grinder
- Safety Glasses

JACKING, SUPPORTING AND PREPARING THE VEHICLE

- a) Block the front wheels of the vehicle with appropriate wheel chocks. Make sure the vehicle's transmission is in "Park" (automatic) or 1st gear (manual). Activate the parking brake.
- b) Loosen, but **DO NOT REMOVE**, the rear wheel lug nuts.
- c) Lift the rear of the vehicle off the ground using a properly rated floor jack. Lift the vehicle so that the rear tires are approximately 6-8 inches off the ground surface.
- d) Support the vehicle using four (4) support stands, rated for the vehicle's weight. The stands should be positioned, two on each of the frame rails, just forward of the front leaf spring hangers and just below the rear leaf spring shackle hangers. Prior to lowering the vehicle onto stands, make sure the supports will securely contact the straight, flat portions of the frame rails. It is very important that the vehicle is properly

supported during this installation to prevent frame damage and personal injury! Make sure that the support stands are properly placed prior to performing the following procedures.

- e) Lower the vehicle slowly onto the stands and, before placing the vehicle's weight on them, again check that they properly and securely contact the frame rails as described above. Check for possible interference with any lines, wires, or cables.
- f) Remove the rear wheels from the vehicle.

SAFETY REMINDER: Check for safe vehicle stability before proceeding under the vehicle to begin the following procedures. Never work under a vehicle supported by only a jack. Always use properly rated support stands to support the vehicle.

1. DIS-ASSEMBLY

- 1a) Remove both rear shocks

Warning: Leaf springs may be under tension. Springs under tension store a great amount of energy. Use caution during the following steps avoid personal injury and/or damage to vehicle. Be careful not to damage the brake hoses and/or driveline while relocating rear axle assembly.

- 1b) Properly support the axle using a jack or lifting device so that it can be raised and lowered. Also support the rear axle near the rear u-joint to keep the axle from rotating once unbolted.
- 1c) Remove the U-bolts using a **21mm** socket (**photo 1**).
- 1d) Remove the lower shackle bolt that connects it to the rear hanger and leave the shackle connected to the spring at this time.
- 1e) Loosen the front spring hanger nuts and bolts. Back the bolt and nut off sufficiently to expose the bolt shank. Due to the fuel tank and exhaust locations, both front spring hanger bolt needs to be cut off. Cut off the head of the bolts, being careful not to damage the fuel tank, exhaust, or frame (**photo 2**).
- 1f) Mark the leaf springs "Left" and "Right". Also mark each forward spring end with a forward pointing arrow so that the springs can be properly reinstalled into their original locations.
- 1g) Remove both leaf springs from under the vehicle. It might be necessary to lower the axle before they can be removed.

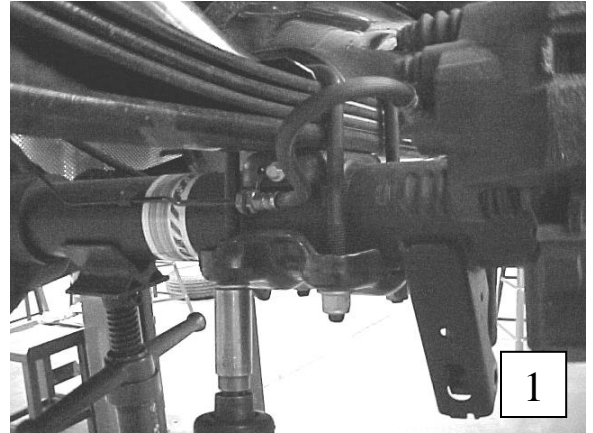

to

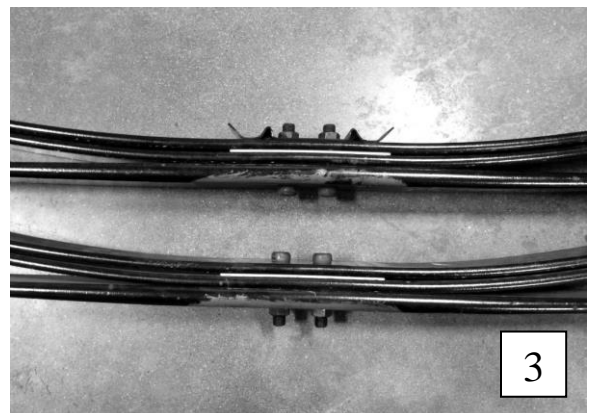
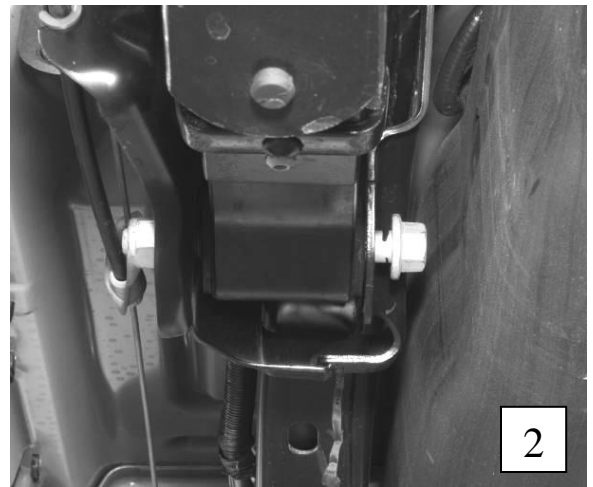

2. LEAF SPRING PREPARATION

- 2a) Remove and reverse both center bolts on the leaf springs. **DO NOT** re-attach the U-bolt locating plate that's bolted to the top of the spring: it is no longer needed. (**photo 3**) **NOTE:** It might be helpful to use a couple of C-clamps

to hold the spring pack together while you reverse the center bolts, or loosen them and reverse one at a time. **(Photo 4)**. Tighten the center bolts using pliers to hold the round head of the bolt.

- 2b) Remove the stock shackle. Note the direction of the bolt head as the bolt will need to be reinstalled the same direction.
- 2c) Assemble the bushing and spacer on the supplied Belltech shackle. Install the shackle onto the leaf spring. Do not tighten the shackle in place it will be tightened after the vehicle has been set down **(photo 5)**.
- 2d) Repeat this process on the other leaf spring.
- 2e) Remove all bolts securing the brake line to the front and rear of the OEM leaf spring mount on each side of the axle **(photo 6&7)**.

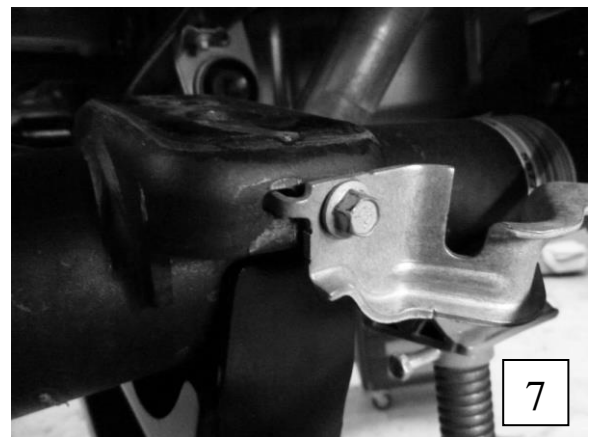
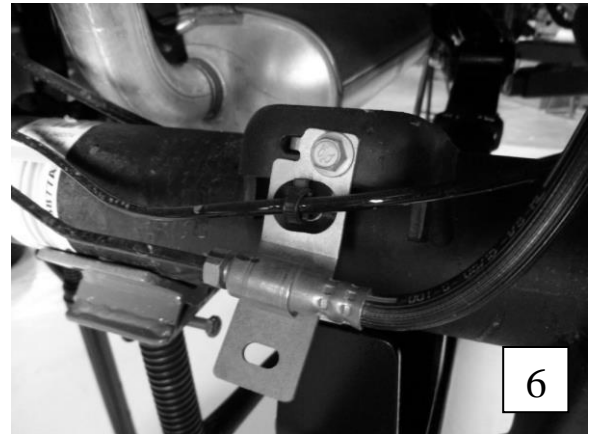
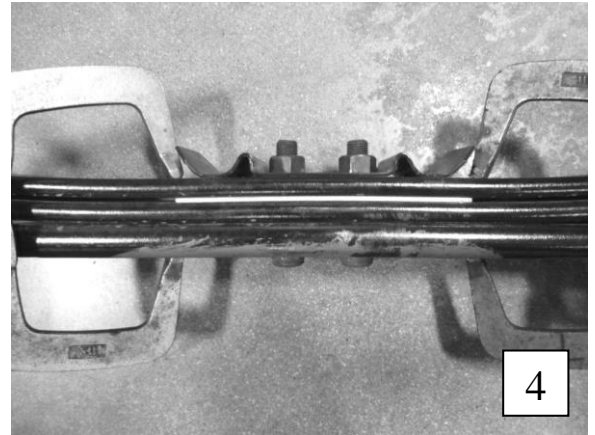

3. LEAF INSTALLATION

- 3a) Raise the axle upward into the vehicle so the springs may pass under the axle and bolt onto the chassis.
- 3b) Start from the passenger side. Place the leaf spring in the front spring hanger and insert the supplied 18x2.5x140mm bolt, washer and nylon lock nut from the outside. Once in, rotate the spring back and insert the lower shackle bolt in the rear hanger. Torque the front spring hanger bolt to **95 ft lb**; leave the rear shackle bolt loose it will be tightened after the vehicle has been set down.
- 3c) Repeat this process on the driver side leaf spring.
- 3d) Install the two axle saddles onto the leaf springs. The saddle should be placed on the leaf spring so that the 2 locating holes are toward the front of the vehicle. **(photo 8)**

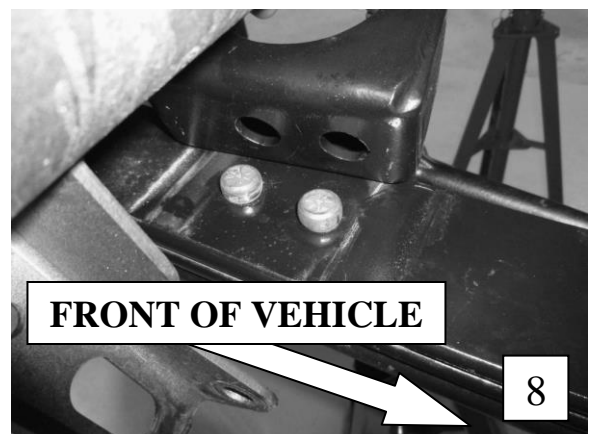

- 3e) Lower the axle into the saddles ensuring the two tabs are positioned up inside the factory spring mount.
- 3f) Install the U-bolt Spring Pad Mount on top of the axle, centering it atop the mount surface. **(Photo 9)**
- 3g) Install the U-bolts and U-bolt plates onto the axle loosely threading the hardware in place. The U-bolt plate will be installed with the notched portion closest to the lower chock mount. **(Photo 10)**
- 3h) Tighten all the U-bolts to 100 ft/lbs.

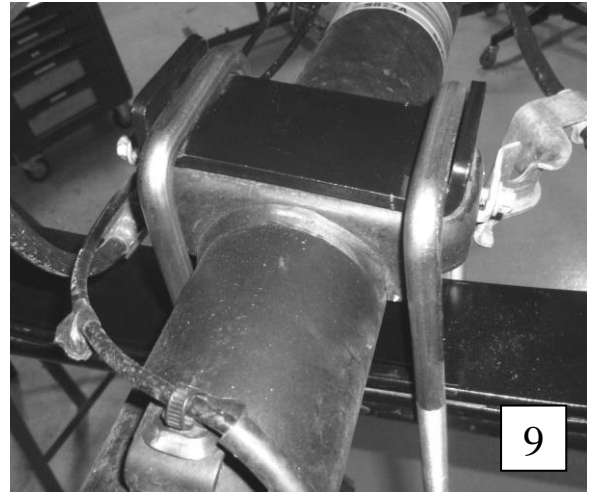

NOTE: The U-bolts are longer than necessary for ease of installation. After securely fastening the U-bolts, the excess ends can be trimmed to 1" below the bottom of the tightened nut

- 3i) Install shorter length shock absorbers. **THE OEM LENGTH SHOCKS ARE TOO LONG AND WILL NOT ALLOW FOR TRAVEL.** We recommend the Belltech Street Performance (2712EE) or Nitro Drop 2 (8580) lowering shocks. The shoulder at the end of each lower shock bolt may need to be trimmed to avoid contact with the U-bolt plate. **(Photo 11)**
- 3j) Install the brake line bracket and securing bolt and tighten to **17 ft lb**. It may be necessary to trim down the tip of the bolts for proper seating.

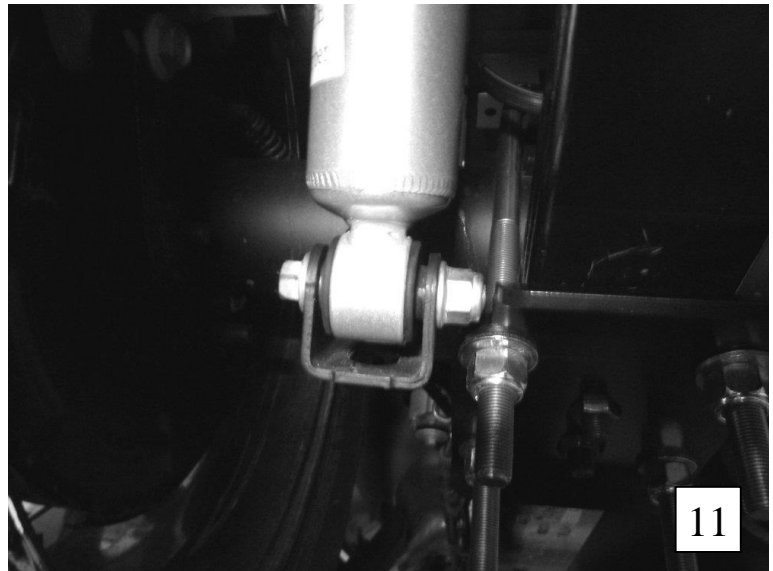
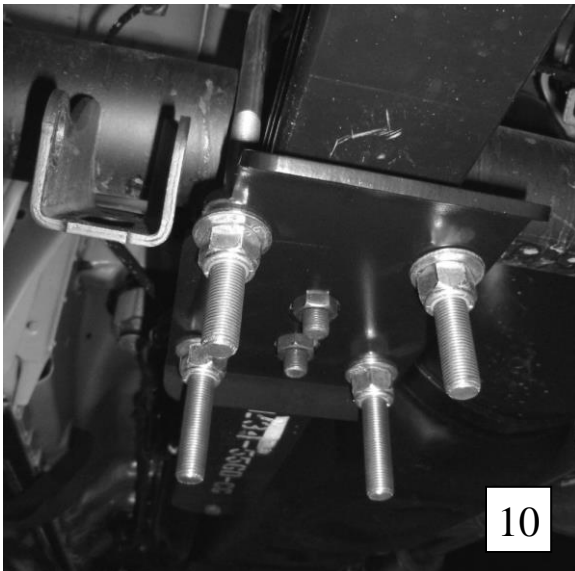

4. BUMP STOP

- 4a) Remove the OEM bump stop by removing the bolt in the center of the bump stop. **(photo 12)**
- 4b) Install the shorter supplied BELLTECH bump stop along with the supplied socket head bolt
- 4c) Repeat process for both frame rails.

5. DRIVELINE ADJUSTMENTS

For models with a two piece driveshaft you will need to re-locate the center carrier bearing mount (CCB).

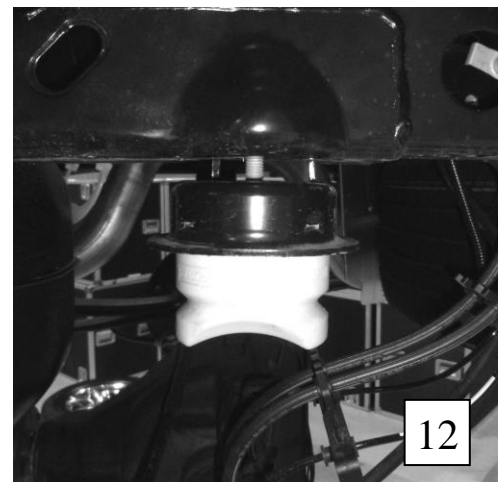

- 5a) Remove the two center carrier bearing bolts. Push the center carrier bearing towards the passenger side of the car and support it in place with a jack or stand. **NOTE:** Be very careful not to drop, dent or damage the driveline or it may have to be replaced.
- 5b) Remove the OEM nut inserts that held the CCB to the crossmember.
- 5c) Use a center punch to mark the crossmember above the existing CCB carrier. **(photo 13)** Drill a ½" hole through both layers of the crossmember. Be sure not to drill in to the floor of the cab which is just above the crossmember.
- 5d) Use an abrasive cutting to cut the welds on the front and rear of the OEM CCB bracket and remove. Be careful not to cut in to or damage the crossmember. Use a grinder to clean up any excess material that was not cut off when removing the mount. You should have two smooth surfaces where the two welds were **(photo 13)**.
- 5e) Connect the center-carrier bearing assembly onto the cross member using the supplied bolts, nuts, and washers **(Photo 14)**. Tighten the bolts to 50 ft lb.

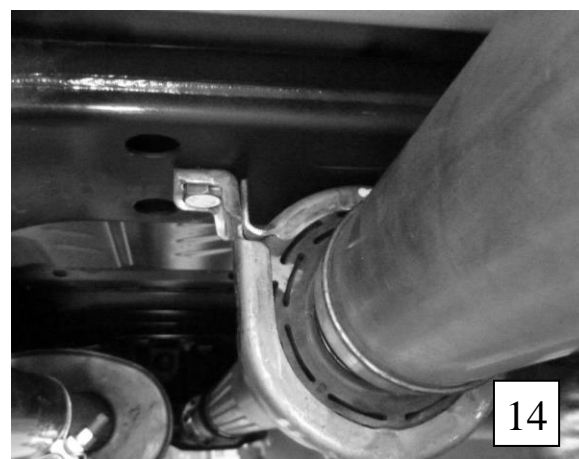
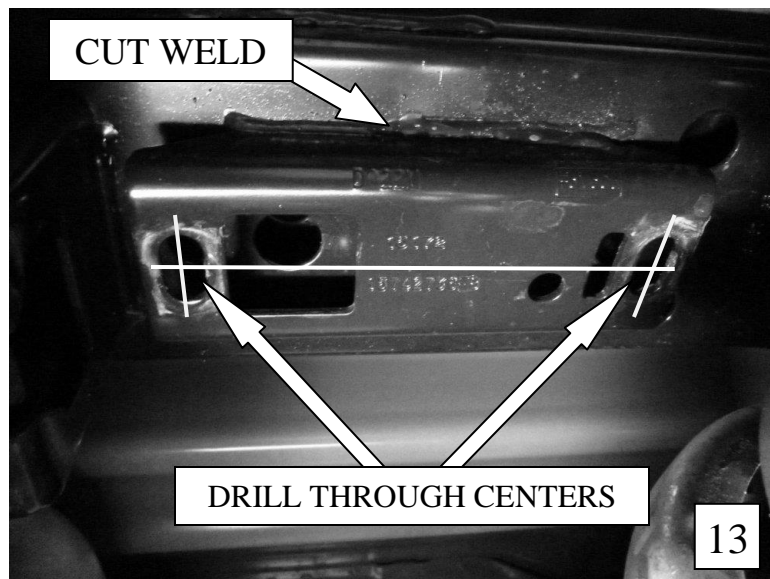

6. **FINALIZING THE INSTALLATION**

- 6a) Re-install wheels and torque to the Manufacturer's specifications.
- 6b) Check that all components and fasteners have been properly installed, tightened and torqued.
- 6c) Lift vehicle and remove support stands. Carefully lower vehicle to ground.
- 6d) Check brake hoses, cables and other components for any possible interference.
- 6e) Check for wheel/tire to chassis/body interference.
- 6f) Once vehicle has been lowered to the ground securely fasten the shackle bolts in place to **100 ft-lb**.
- 6g) Test-drive the vehicle in a remote location so that you can become accustomed to the revised driving characteristics and handling. Be aware that the vehicle will handle substantially different now that it has been lowered.
- 6h) Take the vehicle to a qualified shop for 4-wheel alignment.
- 6i) Check all of the hardware and re-torque at intervals for the first 10, 100, and 1000 miles.

The front of the vehicle **MUST BE** lowered accordingly for proper handling and performance and also to maintain warranty. See the current *Belltech Application Guide* or contact you nearest *Belltech Dealer* for the appropriate part numbers for your application.

The axle adapter saddles have been design to properly position the rear axle pinion shaft relative to the driveline, so that vibrations can be eliminated. If driveline vibrations are experienced, take the vehicle to a driveline service shop immediately for driveline angle inspection and necessary adjustments. DO NOT drive vehicles exhibiting extreme driveline vibrations, as U-joint wear could occur prematurely. Be sure to lubricate the U-joints if deemed necessary.

Parts List: 6446

Part #	Description	Quantity
6446-001	Axle Saddle	2
6440-002	U-bolt Spring Pad	2
6446-005	U-bolt Plate	2
6703-010	Shackle Body	2
6590-005	Shackle Bushing	4
6590-007	Bushing Sleeve	2
6592-007	U-bolt	4
110455	9/16"-18 Nylon Lock Nut	8
110670	9/16" Washer	8
110264	M18-2.5 x 140MM HHCS (For Leaf Spring)	2
110265	M1802.5 Nylon Lock Nut	2
110502	M18 Washer	2
112046	M12-1.5 x 60mm HHCS (For CCB)	2
112292	M12-1.5 Nylon Lock Nut	2
110645	M12 Washer	2
4922-001	Bump Stop	2
112024	M10-1.5 x 30mm SHCS (For Bump Stop)	1



INSTALLATION INSTRUCTIONS

300 W PONTIAC WAY CLOVIS, CA 93612 local: 559-875-0222 fax: 559-876-2249 toll free: 800-445-3767

15001/16001 COILOVER 2015+ FORD F-150 2WD (-1" to -3.5")

Thank you for being selective enough to choose our high quality BELLTECH PRODUCT. We have spent many hours developing our line of products so that you will receive maximum performance with minimum difficulty during installation.

- Note:** Confirm that all hardware listed in the parts list (page 6) is in the kit. **DO NOT** begin installation if any part is missing. Read the instructions thoroughly before beginning this installation.
- Warning:** **DO NOT** work under a vehicle supported by only a jack. Place support stands securely under the vehicle in the manufacturer's specified locations unless otherwise instructed.
- Warning:** **DO NOT** drive vehicle until all work has been completed and checked. Torque all hardware to values specified.
- Reminder:** Proper use of safety equipment and eye/face/hand protection is necessary when using these tools to perform procedures!
- Note:** It is very helpful to have an assistant available during installation.

RECOMMENDED TOOLS:

- Properly rated floor jack and support stands
- Wheel chocks
- Metric socket set up to 27mm
- Metric combination wrench set up to 27mm
- SAE combination wrench set up to $\frac{3}{4}$ "
- Torque wrench
- Ball Joint puller
- Die Grinder with carbide metal cutting bit
- Safety Glasses

JACKING, SUPPORTING AND PREPARING THE VEHICLE

- a) Block the rear wheels of the vehicle with appropriate wheel chocks. Make sure the vehicle's transmission is in "Park" (automatic) or 1st gear (manual). Activate the parking brake.
- b) Loosen, but **DO NOT REMOVE**, the front wheel lug nuts.
- c) Lift the front of the vehicle off the ground using a properly rated floor jack. Lift the vehicle so that the front tires are approximately 6-8 inches off the ground surface.
- d) Support the vehicle using support stands rated for the vehicle's weight. The stands should be positioned in the factory specified locations (refer to owner's manual). Prior to lowering the vehicle onto stands, make sure the supports will securely contact the chassis. It is very important that the vehicle is properly supported during this installation to prevent frame

damage and personal injury! Make sure that the support stands are properly placed prior to performing the following procedures.

- e) Lower the vehicle slowly onto the stands, checking that they properly and securely contact the frame rails as described above before placing the vehicles weight fully on them.
- f) Remove the front wheels from the vehicle.

SAFETY REMINDER: Check for safe vehicle stability before proceeding under the vehicle to begin the following procedures. Never work under a vehicle supported by only a jack. Always use properly rated support stands to support the vehicle.

1. REMOVING THE OEM STRUT

- 1a) Unbolt the brackets holding the brake and ABS lines from the spindle and the frame. Also remove the plastic clip holding the ABS line to the frame and brake line bracket. Be careful not to damage any of the lines. **(photo 1&2)**

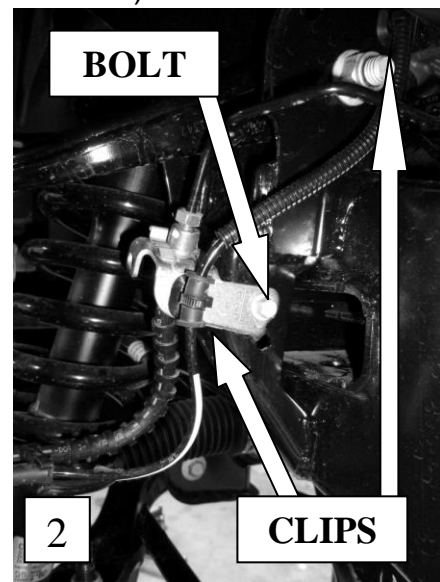
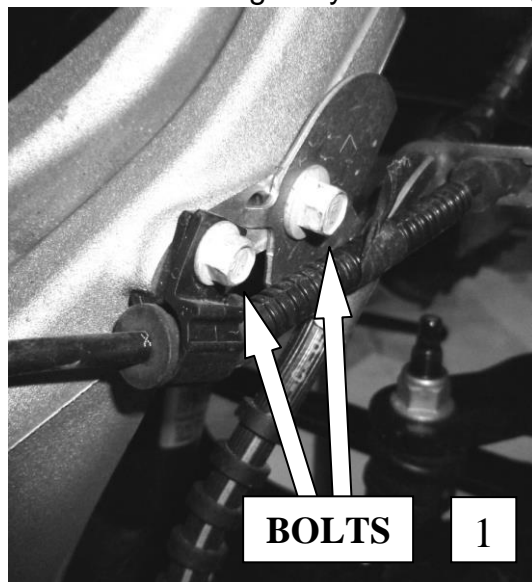

- 1b) Loosen and remove the upper nuts from the sway bar end links. **(photo 3)**

- 1c) Loosen and remove the nuts securing the lower strut mount to the control-arm. **(4)**

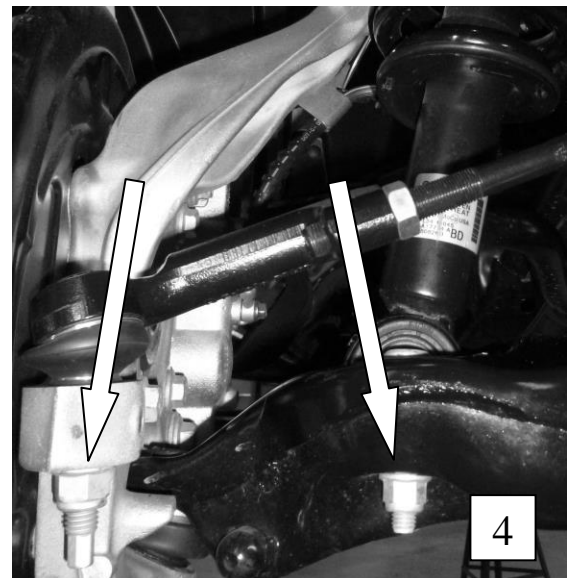
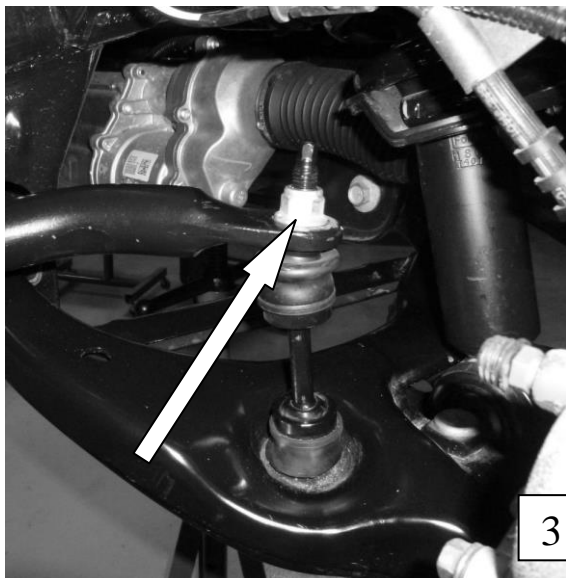

- 1d) Remove the nut securing the tie rod end to the steering knuckle and remove the tie rod end from the steering knuckle. This may require tapping the side of the tie rod end boss with a hammer to unseat the taper. **(photo 4)**
- 1e) Loosen and remove the nut securing the upper ball joint to the steering knuckle. **Please note that the upper control arm may be under tension and, after removing the ball joint, the lower control arm will no longer be supported and may drop downward. Be careful to not allow the brake or ABS lines to become stretched or damaged during this process.** Break the ball joint free from the steering knuckle using the proper ball joint puller. **(photo 5)**
- 1f) Push the steering knuckle and lower control arm down until the lower shock studs are clear from the control arm. Again, do not allow the brake or ABS lines to become stretched or damaged during this process. **(photo 6)**
- 1g) Remove the 3 nuts securing the upper strut mount to the chassis.
- 1h) **Mark the outboard side of the spring and top mount to assist with proper re-assembly and installation. Remove the strut from the chassis.**

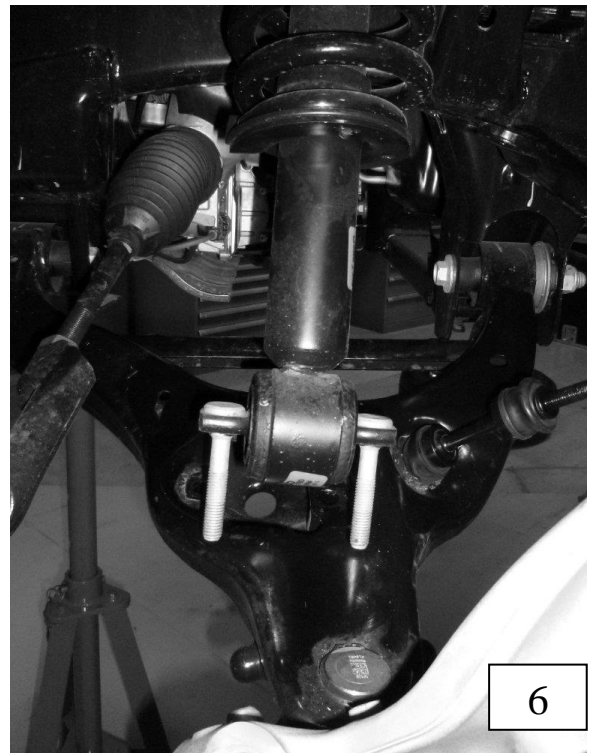
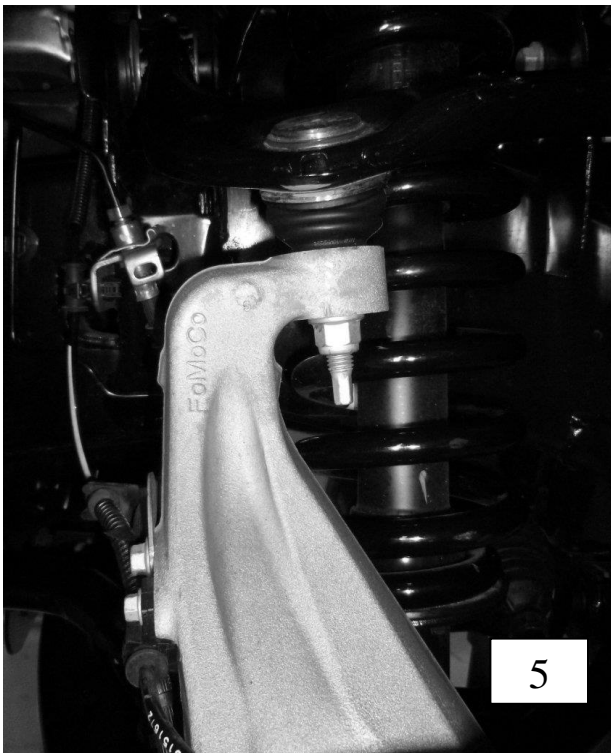

2. COILOVER HEIGHT SETUP

- 2a) Refer to the chart below to determine the “A” measurement to set the drop desired from OEM (Factory height)

Caution: The chart below is designed to use the Belltech 15001 pre-assembled coilover out of the box. This is, an out of the box, lowering solution. Belltech does not recommend lowering beyond what is advertised in the chart below as the performance of the shock may be greatly decreased.

2b) Using the spanner wrench provided in the kit, turn the bottom spring perch (685-10-039) clock-wise to obtain the “A” measurement that is desired.

NOTE: IT IS RECOMMENDED TO PRESET A HIGHER “A” MEASUREMENT AND ADJUST DOWN, CLOCKWISE, TO DESIRED VEHICLE HEIGHT ONCE THE COILOVER IS INSTALLED.

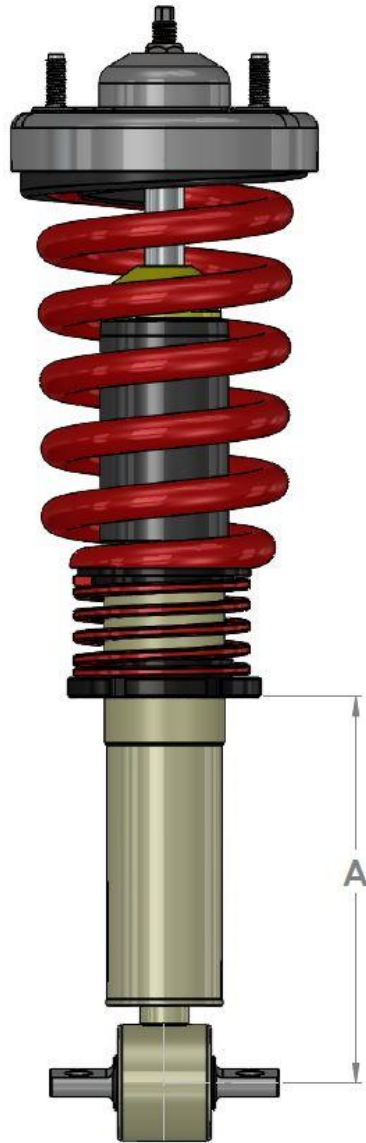

"A" MEASUREMENT	HUB TO FENDER (Drop from OEM)
250 mm	25.4mm (1.0 inch)
240 mm	38.1 mm (1.5 inch)
225 mm	63.5 mm (2.5 inch)
210 mm	88.9mm (3.5 inch)

!! FOR BELLTECH KIT (16001) ONLY, PLEASE READ BELOW!!

THE FRONT COILOVER IS PRE-SET (REBOUND AND COMPRESSION). PLEASE USE THE SUPPLIED ADJUSTMENT KNOB (PART #: 685-25-101) TO ADJUST THE REBOUND VALVE, SEE (FIGURE 1A). ADJUST COMPRESSION BY TURNING, THE BOTTOM, BUILT-IN KNOB CLOCKWISE OR COUNTER-CLOCKWISE. (FIGURE 2A)

CAUTION: MAKING CHANGES TO THE REBOUND AND COMPRESSION VALVES WILL CREATE CHANGES IN THE VEHICLES DRIVING CHARACTERISTICS. PLEASE ADJUST ALL SETTINGS SAFELY AND IN SMALL INCREMENTS AND GET FAMILIAR WITH THE NEW DRIVING CHARACTERISTICS OF THE VEHICLE.

REBOUND	<i>6 CLICKS</i>	<i>OPEN</i>	COMPRESSION	<i>7 CLICKS</i>	<i>OPEN</i>
----------------	-----------------	-------------	--------------------	-----------------	-------------

All adjustments will be done based on a closed valve (max. hard). The closed valve can be reached by turning the adjustment wheel completely to hard (+).

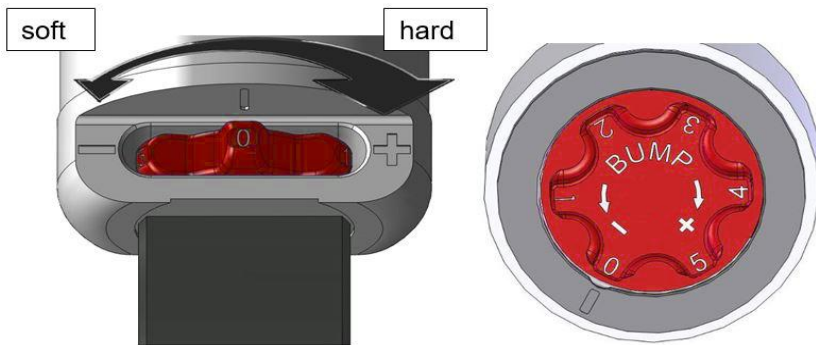
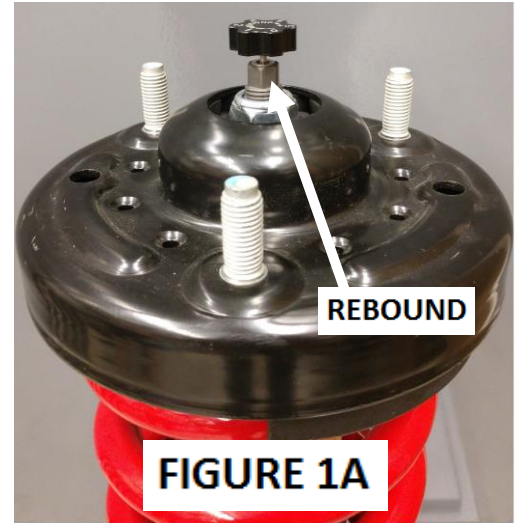

COMPRESSION

3. INSTALLING THE STRUT

3a) Install the top mount into the chassis and secure with the original nuts. Torque nuts to factory specifications. **(Picture 7 & 8)**

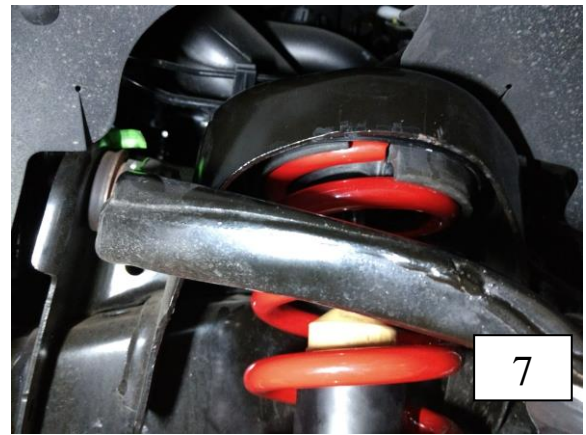

3b) Attach the lower strut mount to the lower control arm using the supplied Bolts washers and nylon lock nuts. Torque the supplied nuts to 60 ft/lbs. **(Picture 9)**

3c) Attach the upper ball joint and tie rod ends to the steering knuckle. Torque nuts to factory specifications. Do not over tighten. **(Picture 10)**

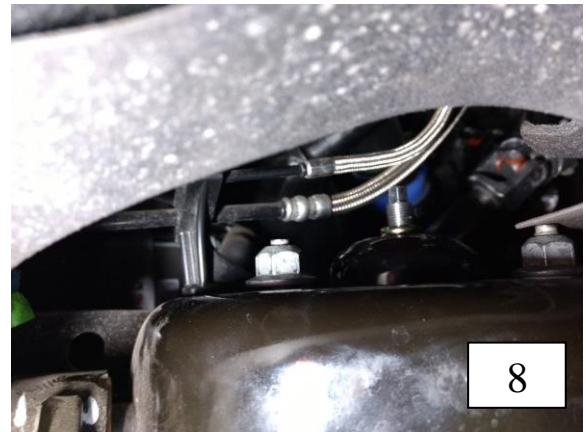

3d) Re-attach the upper end link to the sway bar and tighten to factory specification.

3e) Re-attach all brake and ABS lines using OEM bolts and re-attach plastic clips to their original location

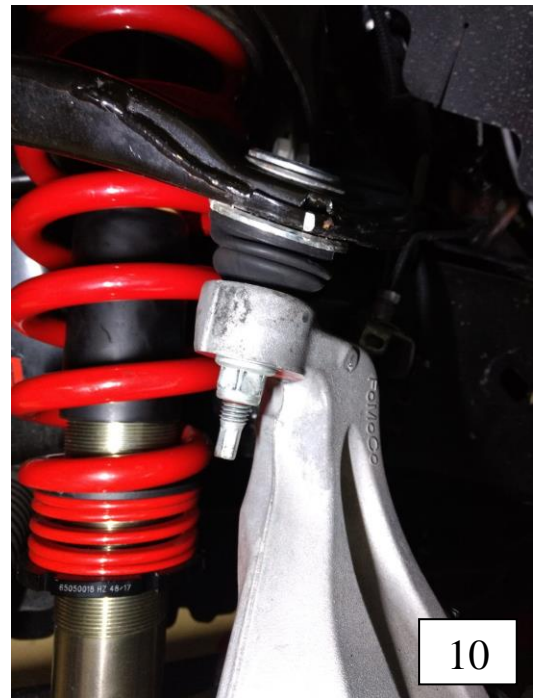
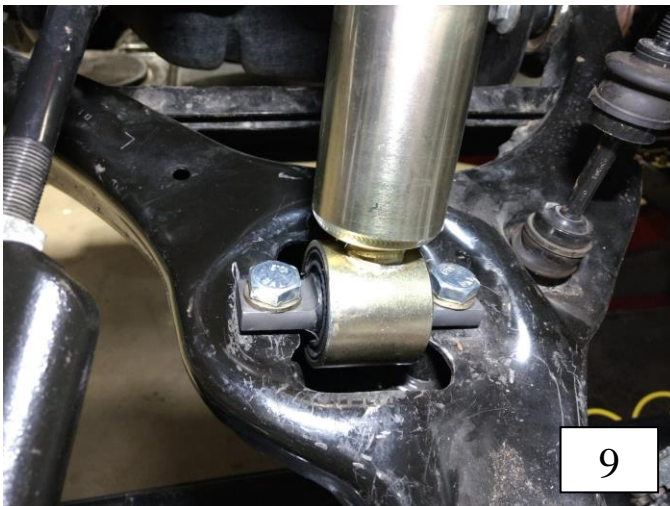

4. ALIGNMENT MODIFICATION

This process is not normally needed for the Belltech 1" to 1.5" drop but is recommended when lowering more than 1.5". This process will allow for additional adjustment to obtain factory spec alignment. If lowering vehicle less than 2", please skip to step 5

- 4a) Remove both bolts securing the lower control arm to the chassis. **(photo 11)**
- 4b) Pull the lower control arm down below the chassis.
- 4c) Scribe a line 1/2" inward from the edge of the factory alignment slot in the chassis. This will need to be done to all 4 slots on each side of the vehicle. **(photo 12)**
- 4d) Use a die grinder with a carbide cutting tip to carefully elongate the slot towards the center of the vehicle. Do not elongate beyond the 1/2" outlined as this will allow the control arm to contact the frame.
- 4e) Remove any burrs after grinding and paint the exposed surfaces to prevent corrosion.
- 4f) Reinstall the lower control arms with OEM bolts and torque to factory specifications.

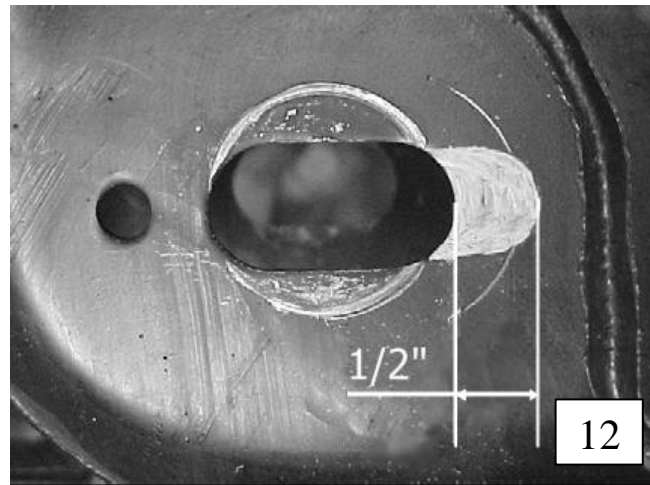
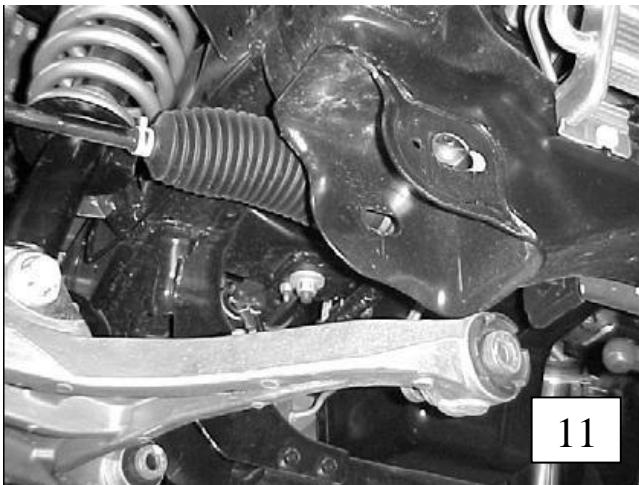

5. FINALIZING THE INSTALLATION

- 5a) All hardware being fastened to the vehicle's original fastening points should be torqued to the proper specifications. To prevent chassis damage, never over-torque the hardware.
- 5b) Check brake hoses and other components for any possible interference.
- 5c) Lift the vehicle and remove the support stands. Carefully lower the vehicle to the ground.
- 5d) **Front end alignment is required immediately following this installation.**
- 5e) Test-drive the vehicle in a remote location so that you can become accustomed to the revised driving characteristics and handling. Be aware that the vehicle will handle substantially different now that it has been modified.
- 5f) Installation is complete. Check all hardware and re-torque at intervals for the first 10, 100, 1000 miles.

Parts List: 15001/16001

Part #	Description	Quantity
15001-100 / 16001-100	COILOVER DAMPER	1
112058	HHCS M14-1.5 X 70MM (LOWER STRUT MOUNT)	2
112298	NYLON LOCK NUT M14-1.5	2
110660	WASHER	2
650-00-018	SPRING PERCH	1
601-10-122	HELPER SPRING	1
650-50-585	INTERMEDIATE RING	1
150-02-105	VENT DISK	1
652-10-799	BUMP STOP	1
652-10-800	DUST COVER	1
5402-001	COILSPRING	1
150-01-265	RUBBER SPRING SEAT	1
150-01-275	TOP MOUNT	1
685-25-101 (16002 ONLY)	ADJUSTMENT KNOB (REBOUND)	1

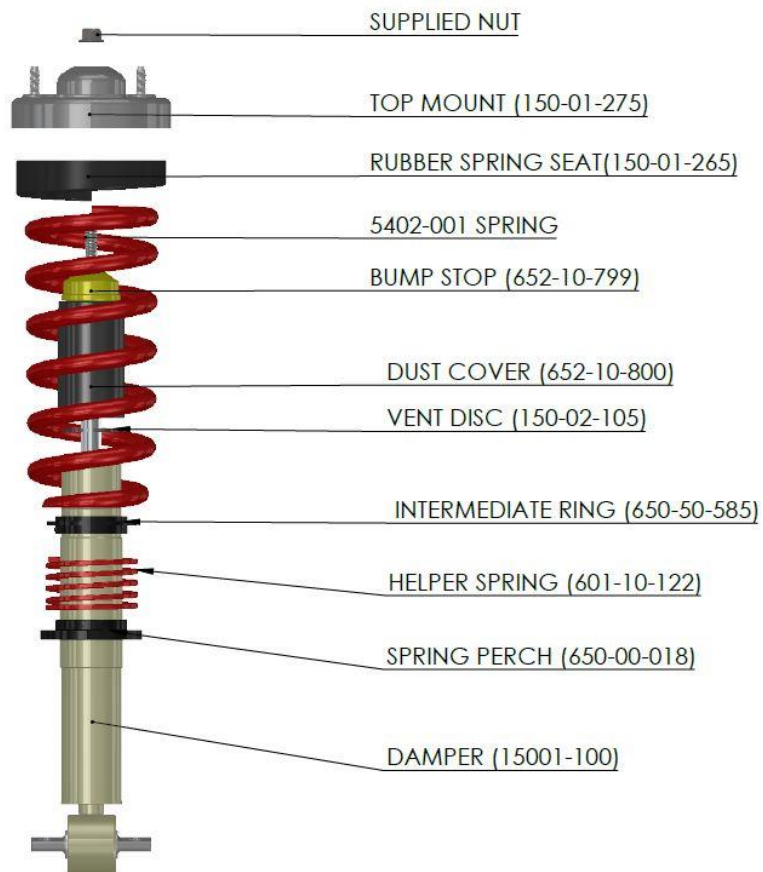



INSTALLATION INSTRUCTIONS

300 W. Pontiac Way Clovis, CA 93612 toll free: 1-800-445-3767 web: www.belltech.com

5559
REAR ANTI-SWAY BAR
2016+ FORD F-150

This anti-sway bar is designed for vehicles with flipped rear suspension!

Thank you for being selective enough to choose our high quality BELLTECH PRODUCT. We have spent many hours developing our line of products so that you will receive maximum performance with minimum difficulty during installation.

- Note:** Confirm that all hardware listed in the parts list is in the kit. **Do not** begin installation if any part is missing. Read the instructions thoroughly before beginning this installation.
- Warning:** **DO NOT** work under a vehicle supported by only a jack. Place support stands securely under the vehicle in the manufacturer's specified locations unless otherwise instructed.
- Warning:** **DO NOT** drive vehicle until all work has been completed and checked. Torque all hardware to values specified.
- Reminder:** Proper use of safety equipment and eye/face/hand protection is necessary when performing the outlined procedures.
- Note:** It is helpful to have an assistant available during installation.

RECOMMENDED TOOLS:

- Properly rated floor jack, support stands, and wheel chocks
- 17/32" drill bit and power drill
- Electric or pneumatic grinder
- Combination wrench: (9/16", 3/4")
- Ratcheting socket wrench and sockets (9/16")
- Safety Glasses

KIT INSTALLATION

1. Open the hardware kit and remove it's contents. Refer to the parts list (Page 5) to verify that all parts are present.
2. Park the vehicle on a smooth, level concrete or seasoned asphalt surface and activate the parking brake. Chock the **FRONT** wheels of the vehicle with appropriate wheel chocks; making sure the vehicle's transmission is in 1st gear (manual) or "Park" (automatic).
3. Using a properly rated floor jack, lift the **REAR** wheels of the vehicle off the ground. Place support stands, rated for the vehicle's weight, in the factory specified locations. Refer to the vehicle Owner's Manual. Prior to lowering the vehicle onto the stands, make sure the supports will securely contact the chassis.

It is very important that the vehicle is properly supported during this installation to prevent personal injury and chassis damage! Make sure that the support stands are properly placed prior to performing the following procedures. We **DO NOT RECOMMEND** using wheel ramps while performing this installation.

4. Thoroughly lubricate the **inside** of the new polyurethane bushings using the grease provided. Locate and attach the bushings on the ends of the Belltech Anti-Sway Bar (ASB) (**Photo 1**). Once located, rotate the bushings slightly to evenly spread the lubricant.
5. Locate the Slot on either side of the vehicle on the underside of the Frame, where the frame meets the rear cross beam. Drill a 17/32" hole, directly above, into the cross beam. The hole should be located evenly between the front and backside of the beam and allow for the bolt to pass through. (**photo 2, 3 & 4 can be used for reference**) *Following Mounting instructions are the same for both sides.*

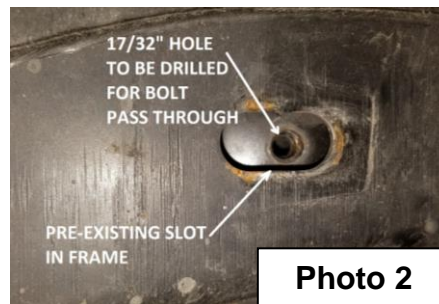
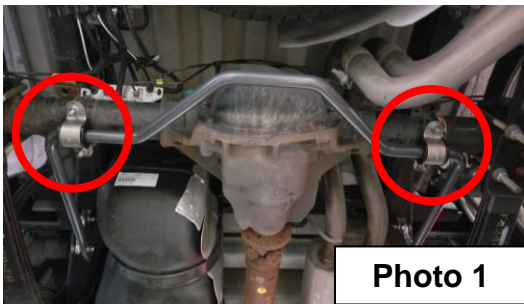

6. Slide the supplied end link mounting bracket plate into the crossbeam far enough for the attached nut to align with the newly drilled hole. The plate labelled 6447-050 is used on the drivers side while 6447-051 is used on the passenger side. The mounting processes are the same on both sides. (**Photo 3 & 4**)

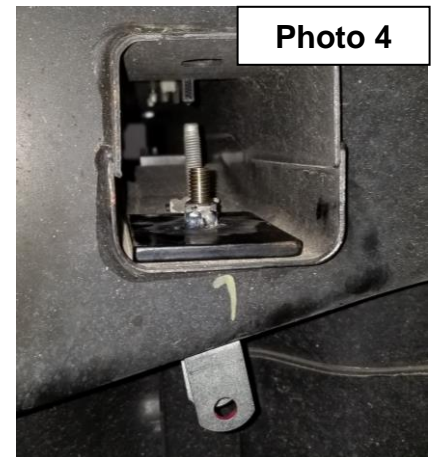

7. Tighten the bracket to the cross beam to 80 ft•lb of torque using the 3" long 3/8" – 16 Bolt. Be Careful not to overtighten and bend the bracket. It may help to insert the end links before tightening. Do not forget a washer between the head of the bolt and bracket to distribute the pressure.

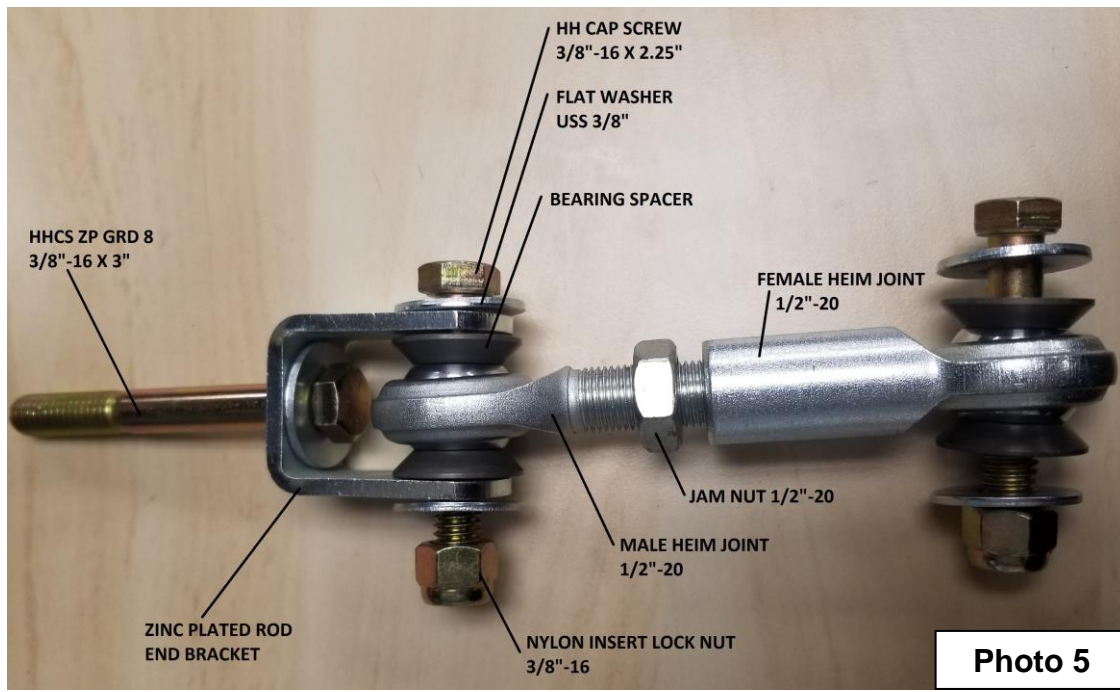

8. Attach the end-link assembly to the mounting bracket and secure hand tight with the supplied 3/8"–16 X 2.25" HHCS bolt, 3/8" – 16 Nyloc nut and 3/8" USS flat washer on each side of the bracket. **(Photo 5)** The jam nut should be tightened to eliminate the Link from coming out of adjustment.

9. Insert the bar from under the vehicle positioning it under the axle with the bar ends pointed forward and above the leaf springs. Once in position, start from one side and place one U-bolt, saddle, and bushing support plate around the axle. **IMPORTANT:** U-bolt is to be placed under the existing brake line and the ASB is not tangled up in the parking brake cables. While holding the U-bolt with one hand, attach the Anti-Sway Bar bushing clamp with the other, and loosely thread the hardware into place using the supplied 3/8" – 16 Nyloc Nut and 3/8" USS flat washer. Do the same to the other side. Do not tighten the U-bolts, as they will be securely fastened after all the other components have been put on. **(See Photo 6 for position reference)**



Photo 6

WD-40™ is recommended to help remove excess lubricant. Re-greasing the pivot bushings should be Performed at regular intervals.

10. Attach the bottom of each end-link assembly onto the Belltech anti-sway bar using the 3/8"–16 X 2.25" HHCS bolt, 3/8" – 16 Nyloc nut, and 3/8" USS flat washers. The end-links should be outboard of the ASB. **(Photo 7)** Make sure there is a washer between the Sway bar and the fastening nut. We recommend testing the Bar in its softest adjustment, which is the hole furthest towards the front of the vehicle, each remaining adjustment will stiffen the roll resistance forces by 10%. **(See Photo 5 for bolt assembly reference)** The endlinks can be adjusted. Adjust the endlinks to get the swaybar as parallel with the ground as possible, while still having at least 7-8 turns of thread remaining.



Photo 7

11. Center the ASB in the bushings once the end-link hardware is tightened (**Photo 6**). Both ASB bushings and bracket assemblies should now be pushed as far outboard as possible so that the bushing is next to the bend in the bar. Anti-Sway Bar bushing clamp and hardware should be rotated onto the bottom side of the axle so that the end links are in a vertical position when looking from the side of the vehicle.
12. Tighten and torque the u-bolt bracket hardware to 19 ft•lbs.
13. All hardware being fastened to the vehicle's original fastening points should be torqued to the proper specifications. To prevent chassis damage, never over-torque.
14. Check that all components and fasteners have been properly installed, tightened and torqued.
15. Check brake hoses, and other components for any possible interference.
16. Lift vehicle and remove support stands. Carefully lower vehicle to ground.
17. Immediately test-drive the vehicle in a remote location so that you can become accustomed to the revised driving characteristics and handling. Be aware that the vehicle will handle substantially different now that it has been modified.
18. Installation is complete. Check all hardware and re-torque at intervals for the first 10, 100, 1000 miles.

! BELLTECH INSTALLATION TIPS

LUBRICATION

Pre-lubricating the inside of the bushing before it's installed is critical. The lubrication will greatly reduce noise and increase bushing life. Belltech recommends you use Molybdenum disulfide to protect the inside surface of the bushing due to its increased life compared to other grease types. Thoroughly lubricate the inside of the bushing with this grease.

BUSHING INSTALLATION

Make sure an amount of 1/32" to 1/16" of the bushing is showing when you install it onto the bracket. See the diagram below. If the bushing is showing more than 1/16" then use a sander or a sheet of coarse grit sand paper to shave it down to the proper height.

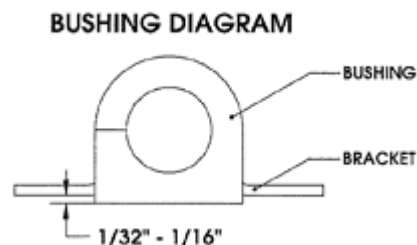

AXLE CLAMP DIAGRAM

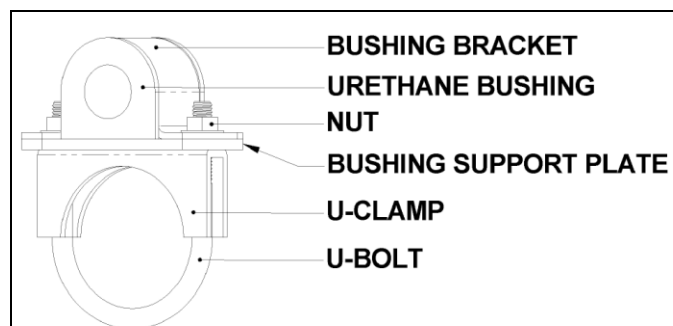

**PART LIST FOR 5559
ANTI-SWAY BAR KIT**

QTY	Part #	DESCRIPTION
1	5559-300	PAINTED REAR SWAY BAR
2	115002-95	ZINC PLATED PIVOT BUSHING BRKT
2	115003-95	ZINC PLATED BUSHING SUPPRT PLT
2	113075	PIVOT BUSHING 1.0"
1	55000-10	GREASE PACK
2	112112	HHCS ZP GRD 8 3/8-16 X 3
8	110255	NYLON INSERT LOCK NUT 3/8"-16
14	112518	FLAT WASHER USS 3/8"
2	112260	U-CLAMP 3-1/4"
1	6447-050-99	POWDERCOATED SWAYBAR MOUNTING
1	6447-051-99	PASS POWDERCOATED SWAYBAR MOUNTING
2	112248	MALE HEIM JOINT 1/2"-20
2	112249	FEMALE HEIM JOINT 1/2"-20
8	57400-045	BEARING SPACER- TOE ADJUSTER
2	112326	JAM NUT 1/2"-20
2	71001-007- 95	ZINC PLATED ROD END BRACKET
4	112106	HH CAP SCREW 3/8"-16 X 2-1/4"