



INSTALLATION INSTRUCTIONS

300 W PONTIAC WAY CLOVIS, CA 93612 local: 559-875-0222 fax: 559-876-2249 toll free: 800-445-3767

25008 LIFT / LOWERING STRUT 0" TO -3" 2015+ COLORADO / CANYON

Thank you for being selective enough to choose our high quality BELLTECH PRODUCT. We have spent many hours developing our line of products so that you will receive maximum performance with minimum difficulty during installation.

- Note: Confirm that all of the hardware listed in the parts list (page 6) is in the kit. **DO NOT** begin installation if any part is missing. Read the instructions thoroughly before beginning this installation.
- Warning:** **DO NOT** work under a vehicle supported by only a jack. Place support stands securely under the vehicle in the manufacturer's specified locations unless otherwise instructed.
- Warning:** **DO NOT** drive vehicle until all work has been completed and checked. Torque all hardware to values specified.
- Reminder: Proper use of safety equipment and eye/face/hand protection is absolutely necessary when using these tools to perform procedures!
- Note: It is very helpful to have an assistant available during installation.

RECOMMENDED TOOLS:

- Properly rated floor jack and support stands
- Wheel chocks
- Metric socket set up to 27mm
- Metric combination wrench set up to 27mm
- SAE combination wrench set up to 3/4"
- Torque wrench
- Abrasive Cutter
- Safety Glasses

JACKING, SUPPORTING AND PREPARING THE VEHICLE

- a) Block the rear wheels of the vehicle with appropriate wheel chocks. Make sure the vehicle's transmission is in "Park" (automatic) or 1st gear (manual). Activate the parking brake.
- b) Loosen, but **DO NOT REMOVE**, the front wheel lug nuts.
- c) Lift the front of the vehicle off the ground using a properly rated floor jack. Lift the vehicle so that the front tires are approximately 6-8 inches off the ground surface.
- d) Support the vehicle using support stands rated for the vehicle's weight. The stands should be positioned in the factory specified locations (refer to owner's manual). Prior to lowering the vehicle onto stands, make sure the supports will securely contact the chassis. It is very important that the vehicle is properly supported during this installation to prevent frame damage and personal injury! Make sure that the support stands are properly placed prior to performing the following procedures.

- e) Lower the vehicle slowly onto the stands, checking that they properly and securely contact the frame rails as described above before placing the vehicles weight fully on them.
- f) Remove the front wheels from the vehicle.

SAFETY REMINDER: Check for safe vehicle stability before proceeding under the vehicle to begin the following procedures. Never work under a vehicle supported by only a jack. Always use properly rated support stands to support the vehicle.

1. REMOVING THE OEM STRUT

- 1a) Remove the guard from the lower center of the truck that covers the center section of the sway bar.
- 1b) Remove the sway bar end links.
- 1c) Remove the bolts securing the sway bar bushing brackets and remove the sway bar.
- 1d) Remove the upper 3 bolts securing the Strut assembly to the chassis.
- 1e) Remove the large lower mounting bolt (**Photo 1**)
- 1f) Pry downward on the spindle and control arm assemblies and remove the strut assembly towards the rear of the vehicle. Be careful not to over extend or damage any brake lines or abs lines during removal. It may be helpful to loosen the brake line bracket located just to the rear of the strut.



2. BUMP STOP

CAUTION! Always use proper safety equipment while cutting metal. Also use precautions not to cause damage or fire from sparks or shavings.

- 2a) Remove the OEM bump stop from the OEM bump stop cup.
- 2b) Cut the OEM bump stop cup off using an abrasive cutting tool. (**Photo 2**) Be careful not to damage any surrounding pieces during cutting process. Belltech does not recommend the use of any type of flame cutting device for this process.



- 2c) Grind the surface flat and remove any burrs. Paint all exposed metal surfaces to prevent corrosion.
- 2d) Install the supplied Belltech bump stop using the hole in the chassis above the OEM bump stop. (**Photo 3**)

3. STRUT DISASSEMBLY

CAUTION! The coil spring is held in place under extreme compression. Belltech recommends the use of a heavy duty spring compressor suitable for truck springs to perform this step. If unsure of your spring compressor capabilities, take this to a professional installer. Use caution during the following steps to avoid personal injury and/or damage to vehicle.

- 3a) Mount the entire spring/strut assembly in the spring compressor fixture. To ease the installation of the new strut, mark a white line down the center of each piece of the assembly for alignment purposes. Note the orientation of the upper mount relative to the bottom bolt eyelet. (**Photo 4**)
- 3b) Compress the spring until the spring is no longer holding tension against the upper and lower spring perch.
- 3c) Hold the strut shaft from spinning and remove the top center nut from the strut. The shock will need to be supported as the nut is removed as it will fall if not supported. Remove the shock and bump stop from the assembly.
- 3d) Remove the plastic cap on top of the OEM shock body and the lower spring perch. Warning removal of the lower spring perch may require significant force. Be careful not to damage the spring perch during removal.

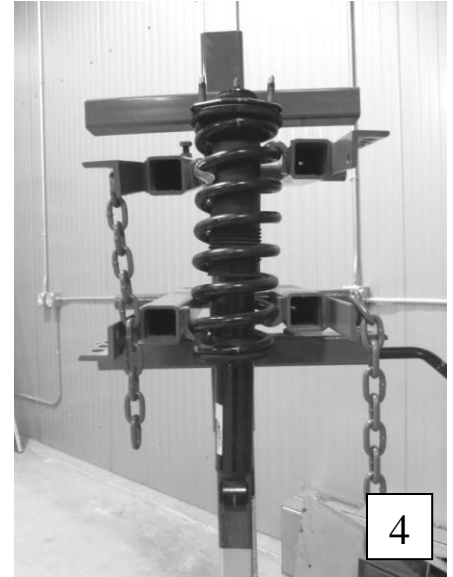

4. ASSEMBLE STRUT

Caution: The chart below is designed to use the Belltech 25008 with the stock vehicle spring. Combining the Belltech 25008 with a lowering spring will require adjusting the ring quantities to adjust for the lowered spring height. Belltech does not recommend total lowering of the vehicle beyond the lowest specification on this chart (3" total lowering) as the vehicle may not be able to be aligned and the performance of the shock may be greatly decreased.

- 4a) Refer to the chart on page 4 to determine the size and number of rings to install for the desired ride height.
- 4b) Assemble the desired number of rings on to the Belltech Street Performance shock body. Slide the OEM spring perch on to the shock above the rings. See diagram on page 4
- 4c) Insert the assembled shock in to the compressed spring and upper spring perch. Secure the shock in to the top mount using the supplied nylon lock nut. Tighten lock nut to 33 ft/lb.
- 4d) Align the strut so the upper mount and the new lower eyelet are oriented the same as the OEM strut assembly.

ITEM DESCRIPTION	NUMBER OF RINGS INSTALLED ON STRUT						
	3" Lowering	2.5" Lowering	2" Lowering	1.5" Lowering	1" Lowering	.5" Lowering	OEM Height
8mm (0.315") Ring	0	1	2	3	4	5	6
End Link	BELLTECH	BELLTECH	BELLTECH	OEM	OEM	OEM	OEM
Hub-Fender Preset(A)	18"	18"	18"	19"	19"	OEM	OEM

5. STRUT INSTALLATION

- 5a) Loosen the upper control arm mounting bolts to release tension on the control arm bushings. **(Photo 5)**
- 5b) Lift the control arm to the correct hub-fender preset for the desired drop. See chart above. **(Photo 6)**
- 5c) Tighten the control arm bushings with the correct hub-fender preset. Torque to factory specifications.
- 5d) Install the strut into position by prying downward on the control arm. Be careful not to cause damage to any of the brake or ABS lines. Insert the upper strut mount first and install the 3 nuts loosely to hold the strut in place.
- 5e) Attach the lower strut mount to the lower control arm using the original bolt. Torque the upper 3 bolts and lower mounting bolt to factory specifications.
- 5f) Reinstall the sway bar using the appropriate end link. (See Chart above & Illustration on page 5 for Belltech end link assembly) Torque bushing bolts and OEM end links (if used) to factory specifications. Tighten the supplied Belltech end link (if used) until the grommets begin to bulge but do not crush them.

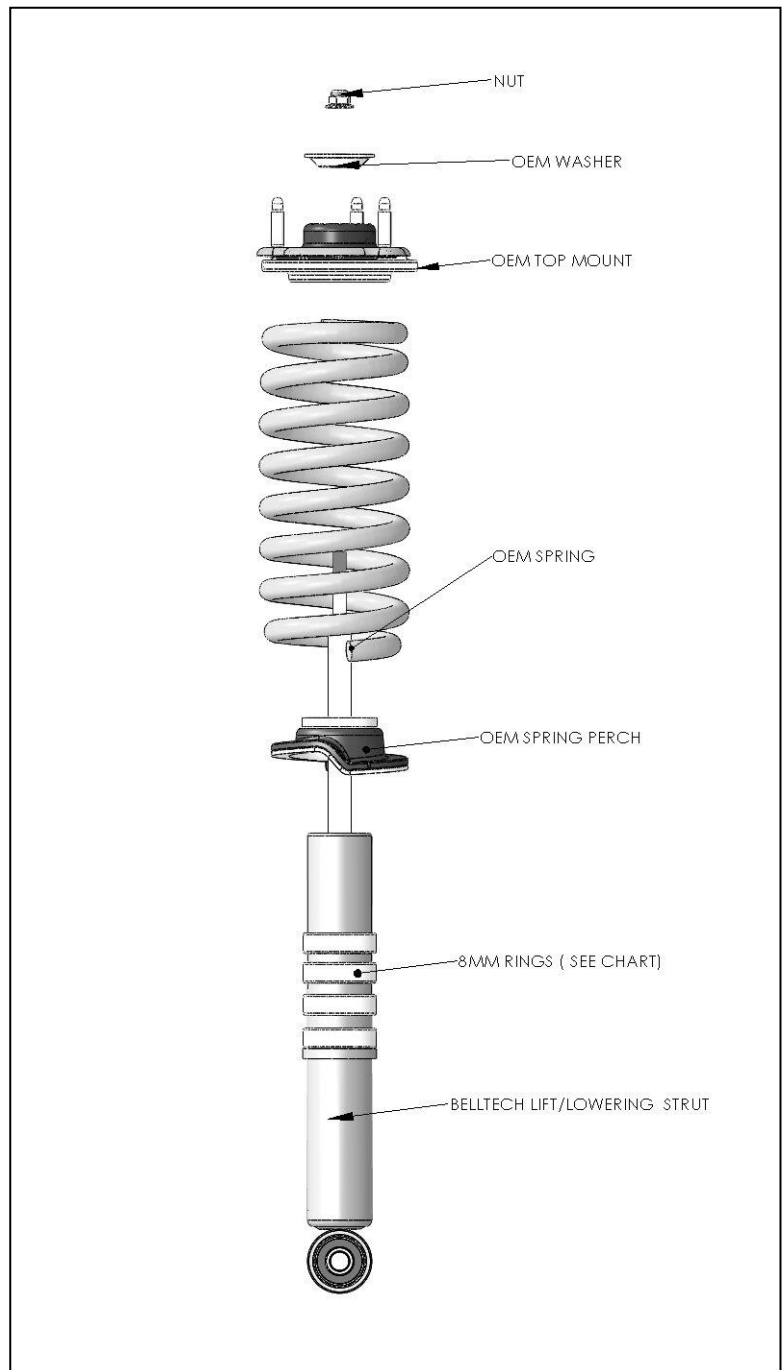

5g) Reinstall the OEM shield below the sway bar and torque bolts to OEM specifications.

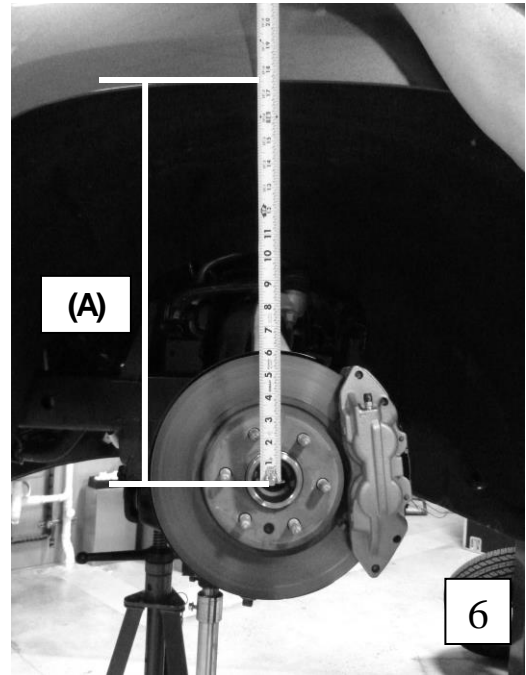
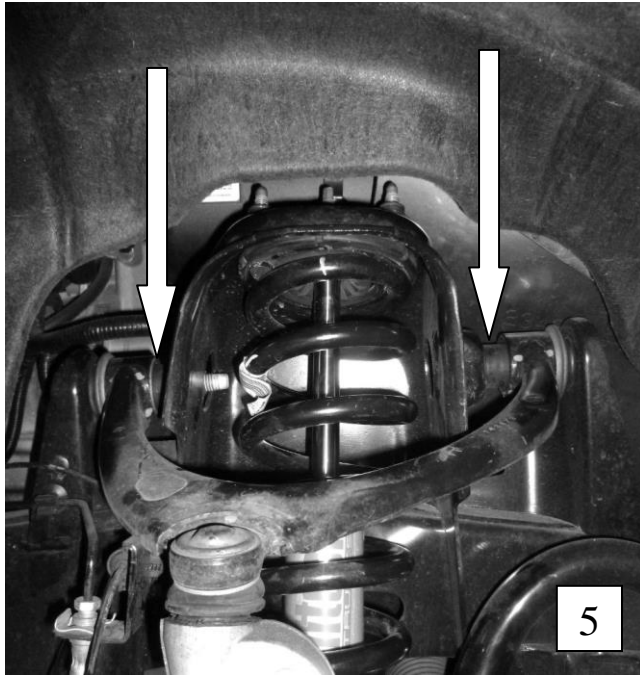

6. FINALIZING THE INSTALLATION

- 6a) All hardware being fastened to the vehicle's original fastening points should be torqued to the proper specifications. To prevent chassis damage, never over-torque the hardware.
- 6b) Check brake hoses and other components for any possible interference.
- 6c) Lift the vehicle and remove the support stands. Carefully lower the vehicle to the ground.
- 6d) **Front end alignment is required immediately following this installation.**
- 6e) Test-drive the vehicle in a remote location so that you can become accustomed to the revised driving characteristics and handling. Be aware that the vehicle will handle substantially different now that it has been modified.
- 6f) Installation is complete. Check all of the hardware and re-torque at intervals for the first 10, 100, 1000 miles.

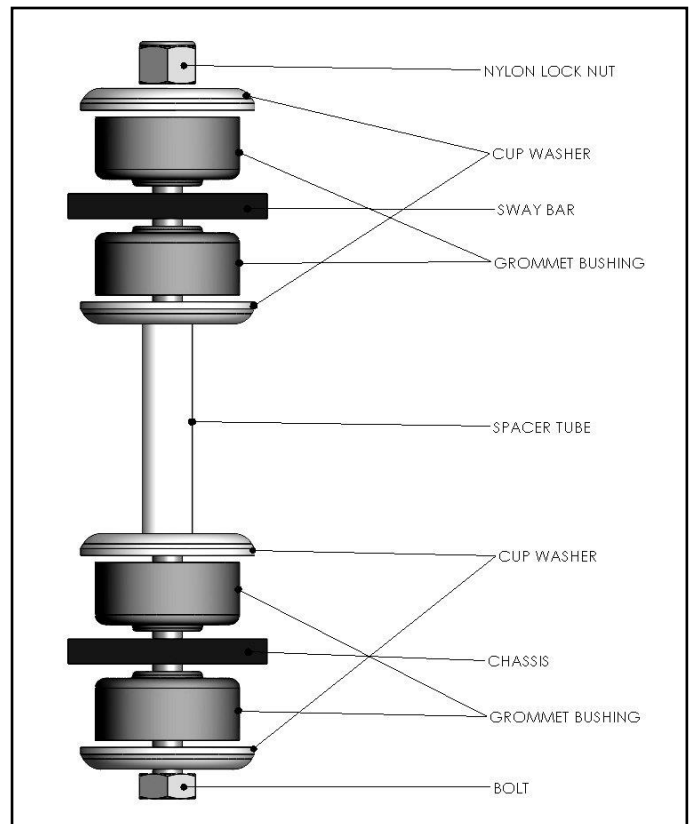

Parts List: 25008

Part #	Description	Quantity
25008-001	SHOCK	1
25003-008	8MM SPACER	6
5922-001	BUMP STOP	1
113000	END LINK GROMMET BUSHING	4
110255	NYLON LOCK NUT	1
112138	HHCS 3/8"-16 X 6.5"	1
112502	WASHER CUP	4
112420	ZINC PLATED SPACER TUBE	1



INSTALLATION INSTRUCTIONS

300 W. Pontiac Way Clovis, CA. 93612 local: 559-875-0222 fax: 559-876-2259
toll free: 800-445-3767

34900

COIL SPACERS 2015+ Colorado / Canyon 2WD / 4WD

Thank You for selecting a BELLTECH PRODUCT. We have spent many hours developing our line of products so that you will receive maximum performance with minimum difficulty during installation.

Note: Confirm that all hardware listed in the parts list is in the kit. **Do not** begin installation if any part is missing. Read the instructions thoroughly before beginning this installation.

Warning: **DO NOT** work under a vehicle supported by only a jack. Place support stands securely under the vehicle in the manufacturer's specified locations unless otherwise instructed.

Warning: **DO NOT** drive vehicle until all work has been completed and checked. Torque all hardware to values specified.

Warning: Be aware that the vehicle can handle substantially different than the Manufacturers Original Design now that it has been modified.

Reminder: Proper use of safety equipment and eye/face/hand protection is necessary when using the recommended tools to perform procedures!

Note: It is very helpful to have an assistant available during installation.

RECOMMENDED TOOLS:

- Properly rated floor jack, support stands, and wheel chocks
- Combination wrench set
- Ratcheting socket wrench and socket set
- Safety Glasses
- Torque wrench

PREPARING FOR INSTALLATION:

- Open the hardware kit and remove contents. Refer to the part list to verify parts are present
- Park the vehicle on a smooth, level hard surface such as concrete and activate the parking brake.
- Block the REAR wheels of the vehicle with appropriate wheel chocks; making sure the vehicle's transmission is in 1st gear (manual) or "Park" (automatic).

VEHICLE HEIGHT:

Measure the current vehicle height NOW using the "Wheel Center to Fender" method shown in Diagram below and record the numbers in the space below:

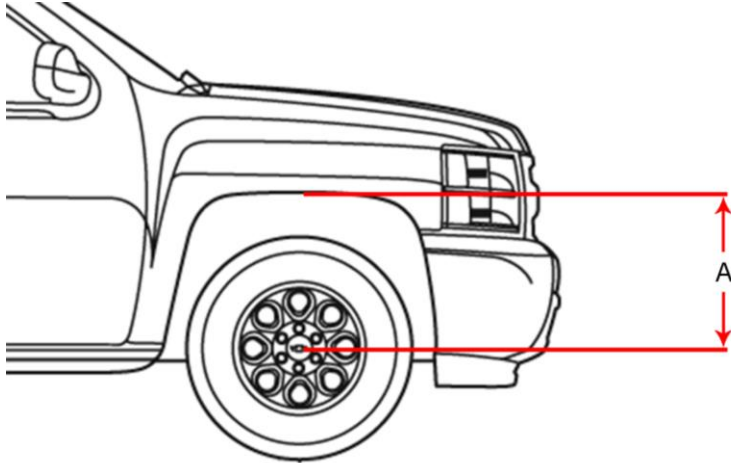

Driver Side: _____“

Passenger Side: _____“

KIT INSTALLATION

- Remove the front wheels.
- Unbolt the tie rod end and separate from the spindle
- Unbolt and remove the sway bar end link
- Unbolt the sway bar from the frame
- Unbolt the Three {3} nuts on the top of the Strut, also remove the bolt at the bottom of the strut
- This will allow you to remove the strut from the vehicle
- Compress the coil and remove the top of the strut, separate the top from the rubber coil isolator.
- Install the aluminum spacer between the 2 reassemble the strut and place the 1/4"spacer on the top of the Strut.
- Re install the strut and tighten to the factory specifications
- Reattach the sway bar to the frame and put the sway bar end links back in place remembering to all ways tighten to the factory specifications.
- Bolt the Tie rods back in place
- Reinstall Wheels
- Repeat for the other side of the vehicle

KIT INSTALLATION CONTINUED

- Lower vehicle to the ground.
- Once vehicle is on ground check the height of the front, side to side.
- Installation is complete. Check all hardware and re-torque at intervals for the first 10, 100, 1000 miles.
- After installing the new components, a wheel alignment should be performed according to manufacturer specifications.

PARTS LIST FOR 34900 KIT

PART No.	DESCRIPTION	QTY.
34900 01	Aluminum Coil Spacer	2
34900 02	¼" Steel Spacer Plate	2