



INSTALLATION INSTRUCTIONS DODGE RAM POCKET STYLE 2002

TOOLS REQUIRED FOR INSTALLATION:

- Jack and Jack Stands (Optional)
- 8mm socket and ratchet
- 3/16 Allen Wrench
- Utility Knife
- # 2 Phillips Driver bit
- 1/2 Wrench
- Drill motor, 5/16 drill bit

IMPORTANT: READ BEFORE BEGINNING INSTALLATION

Verifying Fit - Flares should be held to the vehicle surface to verify correct type and fit BEFORE beginning installation or painting. The inner flare edge should be in contact with the wheel well rim, and the outer flare edge should conform to vehicle fender contours. Small fit adjustments can be made by trimming (filing, sanding or scraping) excess plastic.

Performance - Using larger tires may increase the area required to turn the vehicle. Some Tire/Rim combinations may require lowering bump stops and/or installing steering stops to prevent tire shoulders from contacting flare.

Exhaust System - Modifications may be necessary to maintain a minimum 4" clearance between flares and exhaust pipes. Exhaust gases should not vent directly onto flares.

FLARE INSTALLATION PROCEDURES

Step 1: Painting (Optional)

It is recommended that painting (when desired) be done prior to installation.

- (A) Sand (optional) before application of paint.
- (B) Clean outer surface with a good grade degreaser. DO NOT USE LACQUER THINNER OR ENAMEL REDUCER AS A DEGREASER. Wipe outer surface thoroughly with a tack rag prior to painting.
- (C) Paint flares using a high quality lacquer, enamel, or polyurethane automotive paint. Application of a primer coat is optional.
- (D) If painting edge trim (not recommended) use a flex additive.

Step 2: Preparing the Work Area (Front and Rear)

- (A) Support vehicle and remove wheel using jack and jack stands. (Optional)
- (B) Remove factory fender trim and mud flaps (when installed).

Step 3: Edge Trim Installation (See Illustration #1)

- (A) Peel two to three inches of red vinyl backing away from edge trim tape. Applying the adhesive side of the edge trim to the inner side of the flare, affix the edge trim to the top edge of the flare (the portion that comes in contact with the side of the vehicle).

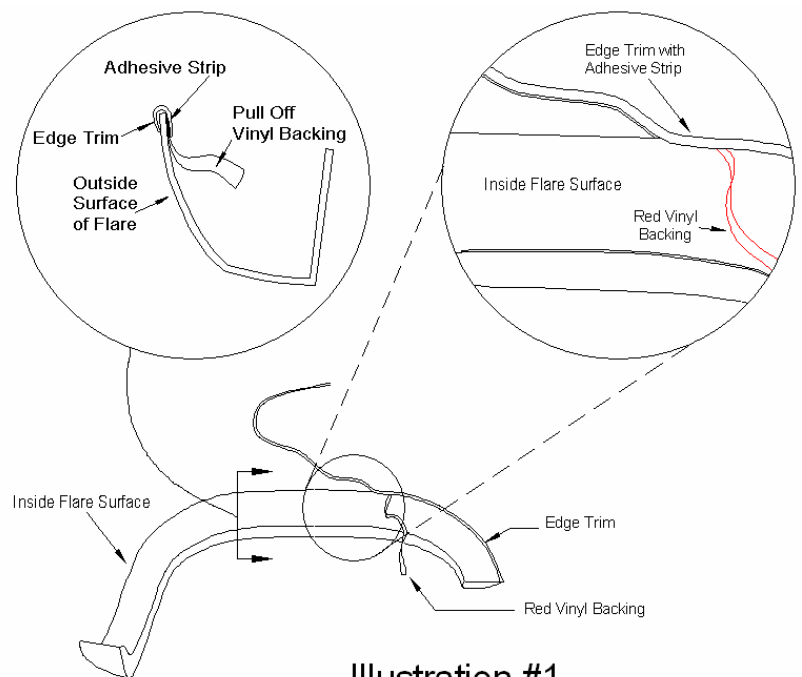
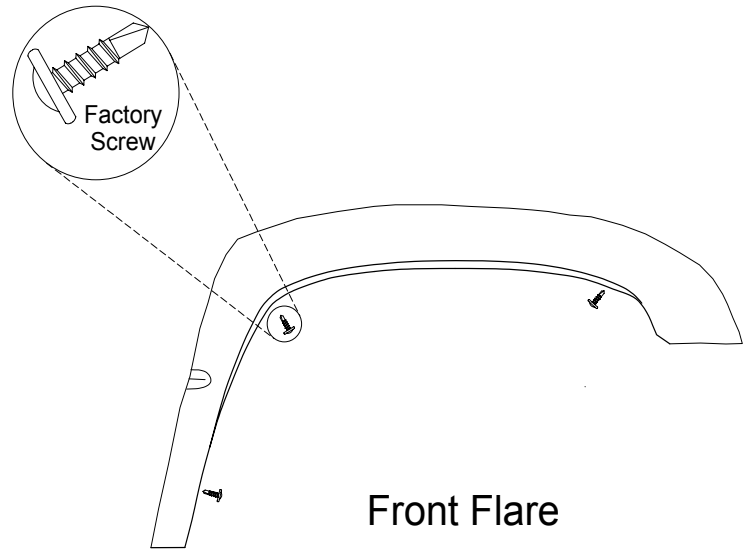

Illustration #1

- (B) Press edge trim into place along the top edge of the flare in one-foot increments, pulling red vinyl backing free as you continue to work your way around the top edge of the flare.

Step 4: Front Flare Installation

- (A) Remove the three factory screws from the front wheel well using a 8MM socket and ratchet. Set aside for further use.
- (B) Using the indents on backside of pockets in flare as a guide drill a 5/16 hole.
NOTE: DRILL HOLES BEFORE PAINT
 Insert stainless steel screw and washer into front of flare, secure with jam nut.
- NOTE: Truck with Cummins logo needs to remove before installing flares.**
- (C) Holding front flare in place on fender, secure with factory screws through holes drilled in the flare.



Step 5: Rear Flare Installation

- (A) Remove the two factory screws from the rear wheel well using a 8MM socket and ratchet. Set aside for further use.
- (B) Using the indents on backside of pockets in flare as a guide drill a 5/16 holes. **NOTE: DRILL HOLES BEFORE PAINT**
 Insert stainless steel screw and washer into front of flare, secure with jam nut Using the indents on backside of pockets in flare as a guide drill a 5/16 hole. Insert stainless steel screw and washer into front of flare, secure with jam nut.
- (C) Install a clip nut, onto the sheet metal at each of the two holes located in the lower front area of the rear wheel well opening.
- (D) Hold rear flare in place on fender, secure with factory screws through the holes drilled in the flare. Install kit supply screws into clip nut, and secure.
- (E) Using the three kits supplied mini clamp style clips. Install the clips using the holes in flare as a guide to locate placement for clip. Attach the clip to the vehicle from inside the wheel well pushing the clip outward **(Making sure the mini clamp is under the fender flare)**
 Install kit supplied setscrew through the holes in flare into mini clamp, now tighten setscrew

