



2003-06 Dodge Cummins **BD Remote Mount Exhaust Brake** **Installation Instructions**

1027138	2003-2004	3½" Exhaust
1027338	2004½-2006	4" Exhaust

Serial # _____

Date Purchased _____

Purchased from _____

Installed by _____

***** Please read this manual before starting installation. *****
OWNER'S MANUAL - LEAVE IN GLOVE BOX

The brake pressure at idle is required to be checked and adjusted at time of install, at least two weeks after install, and at regular twice a year intervals.

BD Engine Brake Inc.

Plant Address: Unit A10, 33733 King Rd, Abbotsford, BC, Canada V2S 7M9

U.S. Shipping Address: 88-446 Harrison St, Sumas, WA 98295 U.S. Mailing Address: P.O. Box 231, Sumas, WA 98295

Phone: 604-853-6096 Fax: 604-853-8749 Internet: www.bd-power.com

TABLE OF CONTENTS

Welcome	3
Special Tools Required	3
Kit Contents (1027138)	3
Kit Contents (1027338)	3
Accessories	4
Pre-Installation	4
Installation	5
Compressor & Regulator Installation	5
<i>Regulator Assembly</i>	5
<i>Air Compressor Mounting Installation</i>	5
In-Cab Exhaust Brake Wiring.....	7
Cruise Control Wiring Installation	7
Accelerator Pedal Position Sensor Wiring (2003-04½).....	8
Accelerator Pedal Position Sensor Wiring (2005-06).....	9
Battery mounted APPS Installation	10
Switch Install (Required if using main toggle switch)	11
Brake Valve Installation (2003-2004)	13
Brake Valve Installation (2004-06)	15
Air Solenoid Installation.....	17
Air Hose Installation	17
Wiring & Plumbing Diagram	19
DFIV Adjustment & Testing.....	20
Notes On Connectors	21
Optional Manual Shifter Switch (Push-Pull Style)	22
Optional Manual Shifter Switch (Rocker Switch Style)	23
Idle Pressure Adjustment	24
Maintenance & Troubleshooting	25
Operating Guidelines	25
Limited Warranty Statement	27

BD Engine Brake Inc.

Plant Address: Unit A10, 33733 King Rd, Abbotsford, BC, Canada V2S 7M9

U.S. Shipping Address: 88-446 Harrison St, Sumas, WA 98295 U.S. Mailing Address: P.O. Box 231, Sumas, WA 98295

Phone: 604-853-6096 Fax: 604-853-8749 Internet: www.bd-power.com

Welcome

Thank you for purchasing a BD Exhaust Brake. This manual is divided into different areas to assist you with your installation and operation of your braking unit. We strongly suggest that you write down the kit and serial numbers of your unit in the spaces provided and retain this manual for any future reference.

Special Tools Required

- Measuring tape or ruler
- Drill with 1/8", 3/16" bits and Unibit
- Sawsall or hacksaw
- Crimping Pliers
- Test light
- 1/4" Drive Socket Set
- Small bladed flat tip screwdriver
- Welder

Kit Contents (1027138)

1	1127038	Valve Assembly
1	1220139	Regulator/Control Kit
1	1030129	Compressor Kit
1	1220113	Air Snorkel Kit
1	1220048	Air Solenoid Assy.

1	1321039	DFIV Application Kit
2	1100350	3½" Pipe Adapter
2	1100404	4" Marmon Clamp
1	1100735	3½" S/S Exhaust Clamp

Kit Contents (1027338)

1	1127038	Valve Assembly
1	1220139	Regulator/Control Kit
1	1030129	Compressor Kit
1	1220113	Air Snorkel Kit
1	1220048	Air Solenoid Assy.

1	1321039	DFIV Application Kit
2	1100400	4" Pipe Adapter
2	1100404	4" Marmon Clamp
1	1100740	4" S/S Exhaust Clamp

BD Engine Brake Inc.

Plant Address: Unit A10, 33733 King Rd, Abbotsford, BC, Canada V2S 7M9

U.S. Shipping Address: 88-446 Harrison St, Sumas, WA 98295 U.S. Mailing Address: P.O. Box 231, Sumas, WA 98295

Phone: 604-853-6096 Fax: 604-853-8749 Internet: www.bd-power.com

Accessories

Description	Part #
Manual Transmission Shifter Switch Kit	1300210
AutoLoc Converter Lock-up Clutch Kit (1994-05)	1030390
TowLoc Transmission & Converter Package	CALL
X-Monitor Digital Gauge Package	1085220
Brake Pressure Gauge Kit	1030550
Boost Pressure Gauge Kit (30lbs.)	1030570
Transmission Gauge Kit (Auto Transmission)	1030583
Exhaust Temperature Gauge (Pyrometer)	1030512

Pre-Installation

To prevent damage to electronic components, it is recommended that you disconnect both negative battery terminals before starting.

Please read this manual thoroughly before installing this exhaust brake.

BD Engine Brake Inc.

Plant Address: Unit A10, 33733 King Rd, Abbotsford, BC, Canada V2S 7M9

U.S. Shipping Address: 88-446 Harrison St, Sumas, WA 98295 U.S. Mailing Address: P.O. Box 231, Sumas, WA 98295

Phone: 604-853-6096 Fax: 604-853-8749 Internet: www.bd-power.com

Installation

Compressor & Regulator Installation

Regulator Assembly

Locate the large oval hole on the passenger side of the vehicle near the upper cowling of the firewall. To the right of this you can either drill a 3/8" hole or use the existing hole by removing the factory plastic locking insert.

Install the regulator assembly underneath the hole (shown on figure to the right). The lock washer and flat washer should be installed on top of the plastic cowling with the Phillips screw holding everything in place.

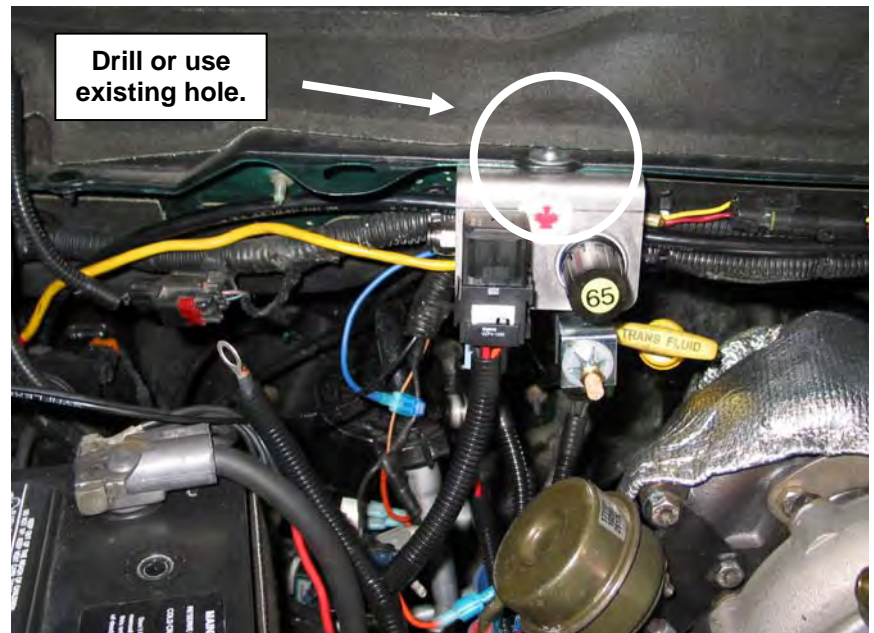

Air Compressor Mounting Installation

You will need to remove the inner front fender well on the passenger side of the vehicle. There are eight bolts holding the lining in place. If you can put the vehicle on a hoist about 3 feet above the ground it will ease this installation.

Locate the hood support bolt up inside of the fender well; it is very close to the bottom of the radio antenna. Remove the bolt closest to the battery tray or closest to the front of the vehicle. Slide the compressor assembly up into this space and re-install the hood support bolt. Now raise the compressor assembly so that you can install the provided bolt through the bracket and frame hole into the



BD Engine Brake Inc.

Plant Address: Unit A10, 33733 King Rd, Abbotsford, BC, Canada V2S 7M9

U.S. Shipping Address: 88-446 Harrison St, Sumas, WA 98295 U.S. Mailing Address: P.O. Box 231, Sumas, WA 98295

Phone: 604-853-6096 Fax: 604-853-8749 Internet: www.bd-power.com

nut. Note that you can use a magnet to assist in holding this nut into place will you slide the bolt through.

Tighten all bolts and secure assembly. Route the compressor pigtail wiring harness up towards the regulator assembly you previously installed. You will also need to route a small section of plastic air hose from the quick connect of the air compressor to the regulator assembly. Use the wiring diagram on page 19 as a reference for the wiring of the air hoses and the electrical wiring. **NOTE:** Be sure to keep all hoses and wiring harnesses away from any moving parts or heat sources.

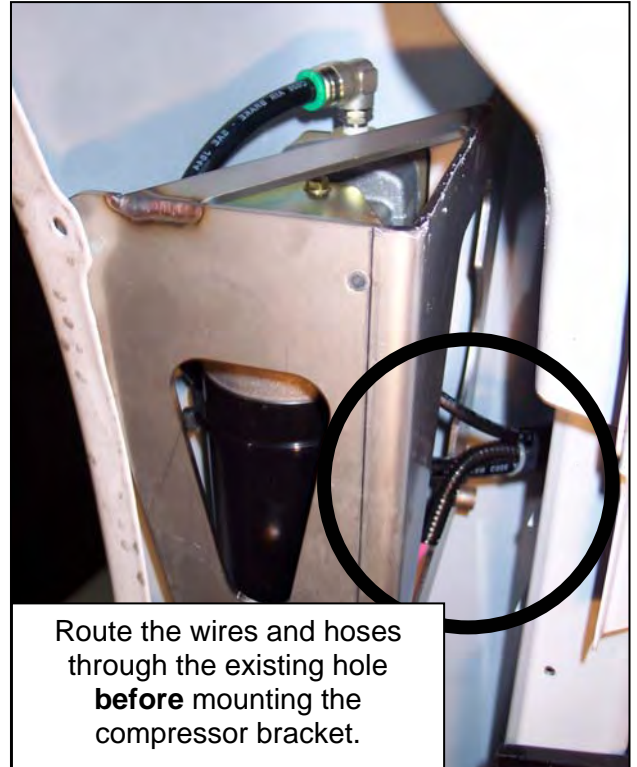

Route the wires and hoses through the existing hole **before** mounting the compressor bracket.

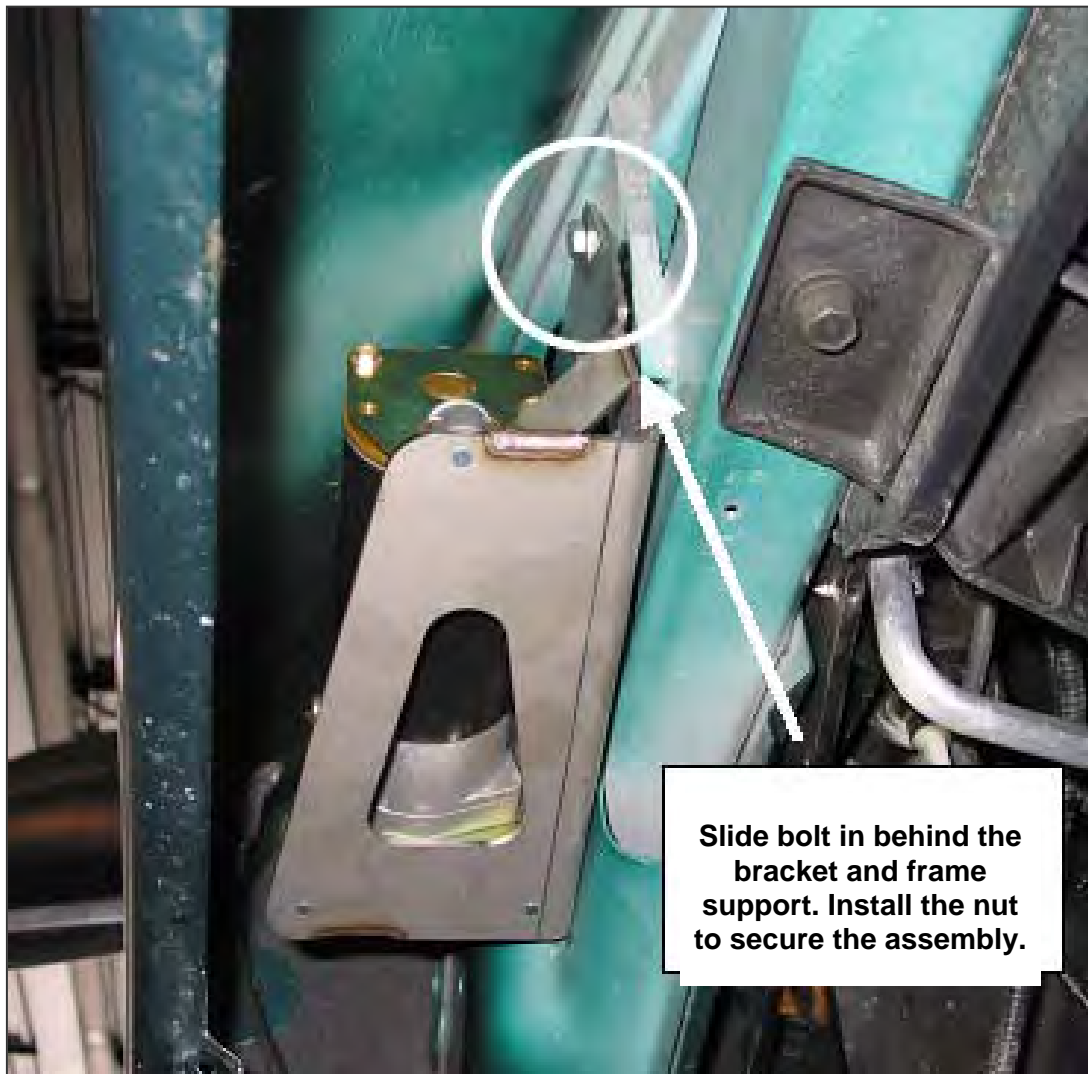

Slide bolt in behind the bracket and frame support. Install the nut to secure the assembly.

BD Engine Brake Inc.

Plant Address: Unit A10, 33733 King Rd, Abbotsford, BC, Canada V2S 7M9

U.S. Shipping Address: 88-446 Harrison St, Sumas, WA 98295 U.S. Mailing Address: P.O. Box 231, Sumas, WA 98295

Phone: 604-853-6096 Fax: 604-853-8749 Internet: www.bd-power.com

In-Cab Exhaust Brake Wiring

NOTE: IF A BD TOWLOC IS TO BE INSTALLED WITH THIS BRAKE YOU MUST SKIP THE WIRING SECTION IN THIS MANUAL AND FOLLOW THE TOWLOC INSTRUCTIONS FOR CORRECT WIRING INSTALLATION. IF INSTALLING A TOWLOC GO DIRECTLY TO PAGE 13/15 AND CONTINUE WITH BRAKE VALVE INSTALLATION.

Cruise Control Wiring Installation

(Manual Transmissions & 2005-06 Automatics Only)

To obtain access to the Cruise Control wiring harness, remove the lower steering column panel by removing the mounting screws and unsnapping the panel from the instrument panel.

Under the dash running vertical by the left of the steering column, locate the smaller wiring harness that runs out of the main harness. Remove some of the black electrical tape to gain access to the smaller wire bundle.

*****DANGER*****

THERE IS A BLACK WIRE WITH A TWISTED LIGHT BLUE/GREEN TRACER. DO NOT CONNECT OR TEST THIS WIRE AS IT IS CONNECTED TO THE AIR BAG SYSTEM AND THE BAG MAY DEPLOY CAUSING DAMAGE AND/OR INJURY.

Remove some of the black electrical tape from the small bundle to gain access to the cruise control wires.

Vehicle	Cruise Control Wire Color	DFIV Wire color
2003 Dodge Manual Trans.	BK/LB	Blue
	R/LG	Green
2004–05 Dodge Manual Trans.	VT	Blue
	VT/BR	Green
2005-06 Dodge Auto Trans.	VT	Blue
	VT/BR	Green

Attach the supplied red (or gray) 18-22ga Posi-Taps™ to each correct wire and use the blue and green wires to connect them to the DFIV.

BD Engine Brake Inc.

Plant Address: Unit A10, 33733 King Rd, Abbotsford, BC, Canada V2S 7M9

U.S. Shipping Address: 88-446 Harrison St, Sumas, WA 98295 U.S. Mailing Address: P.O. Box 231, Sumas, WA 98295

Phone: 604-853-6096 Fax: 604-853-8749 Internet: www.bd-power.com

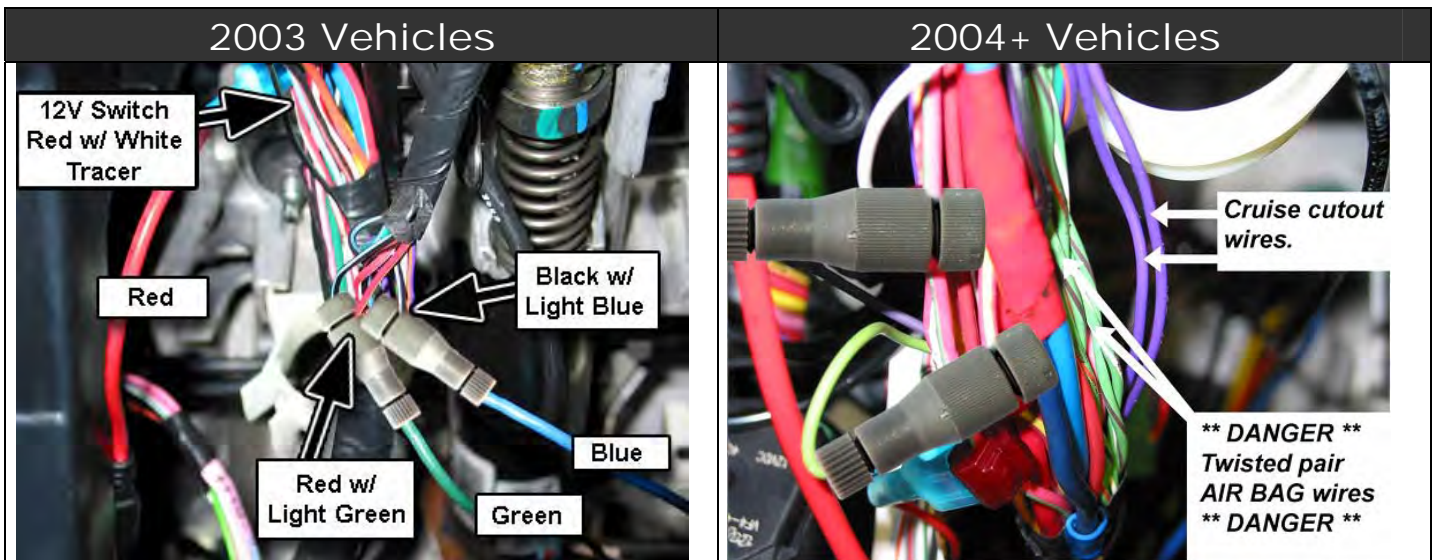

Locate a grommet on the firewall and cut an opening in it to run the loom covered wiring through the firewall.



Accelerator Pedal Position Sensor Wiring (2003-04½)

Route the Yellow wire from the DFIV module along the driver side of the engine to the throttle linkage and APPS Sensor.

Remove the cover of the throttle linkage then locate and disconnect the wiring connector for the APPS.

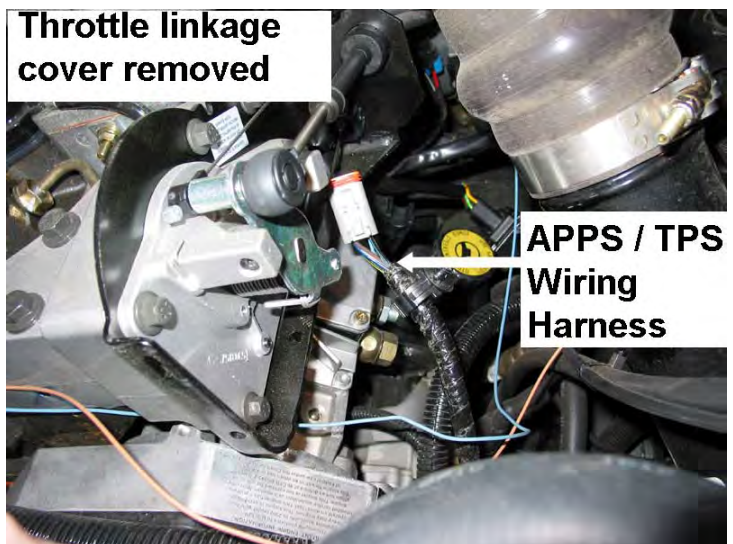

Application	Wire Color	Location
2003-04 Manual/Auto Trans	Yellow	C1 Pin 14
2004½ Auto Trans	BR/WT	C1 Pin 14
2004½ Manual Trans	DB/WT	C1 Pin 14
** Battery mounted APPS	WH/GR	C1 Pin 14

BD Engine Brake Inc.

Plant Address: Unit A10, 33733 King Rd, Abbotsford, BC, Canada V2S 7M9

U.S. Shipping Address: 88-446 Harrison St, Sumas, WA 98295 U.S. Mailing Address: P.O. Box 231, Sumas, WA 98295

Phone: 604-853-6096 Fax: 604-853-8749 Internet: www.bd-power.com

Connect the Yellow wire from the DFIV Module to this Posi-Tap™ and reconnect the APPS connector then reinstall the throttle linkage cover.

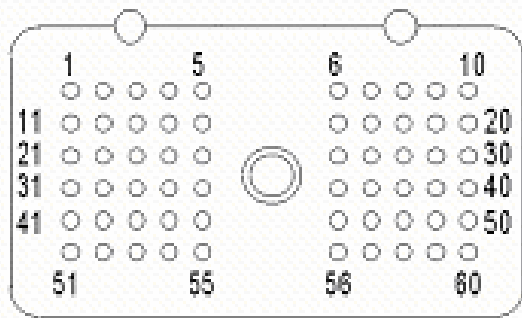

ENGINE CONTROL
MODULE C1
(DIESEL)

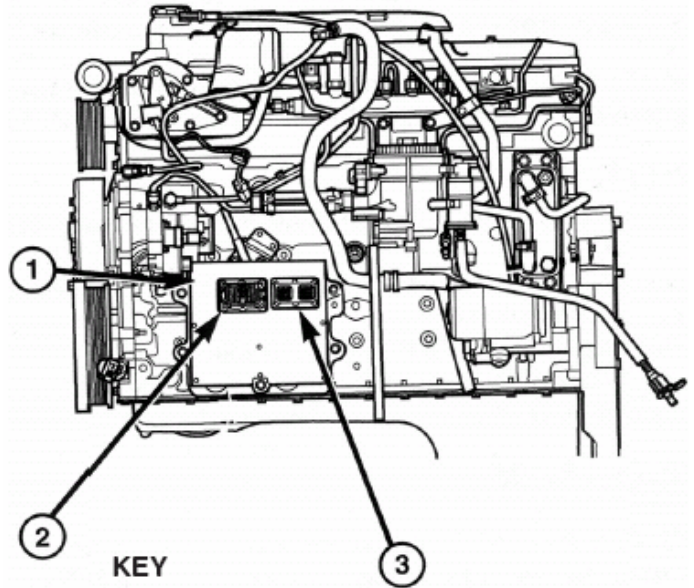

- KEY
- 1. Engine Control Module (ECM)
 - 2. 60-Way Connector
 - 3. 50-Way Connector

Accelerator Pedal Position Sensor Wiring (2005-06)

Route the **yellow** wire from the DFIV module to the accelerator pedal position sensor located on the accelerator pedal. Locate and connect a Posi-Tap to the correct wire color for your application. The yellow DFIV wire should now be connected to the correct APPS wire.

APPS Location (Accelerator Pedal)	APPS Plug

APPS Plug Pin	Circuit / Wire Color	Function
5	K23 20BR/WT	APPS NO. 1 SIGNAL

BD Engine Brake Inc.

Plant Address: Unit A10, 33733 King Rd, Abbotsford, BC, Canada V2S 7M9

U.S. Shipping Address: 88-446 Harrison St, Sumas, WA 98295 U.S. Mailing Address: P.O. Box 231, Sumas, WA 98295

Phone: 604-853-6096 Fax: 604-853-8749 Internet: www.bd-power.com

Battery mounted APPS Installation

RAM 3500: On some truck configurations (i.e. 2003 RAM 3500) the throttle cable/APPS will be located UNDER the driver side battery tray and is accessible by removing the inner fender skirt.

Once the fender skirt is removed the APPS wiring harness can be accessed.

Locate the White with Green Tracer wire and install the gray/red (18-22ga) Posi-Tap™ to it. Route the yellow wire from the DFIV "APPS" output and attach it to the White w/ Green Tracer wire.

Route the orange wire from the DFIV module over the engine and along the firewall cowl to the air compressor and connect the blue connectors.

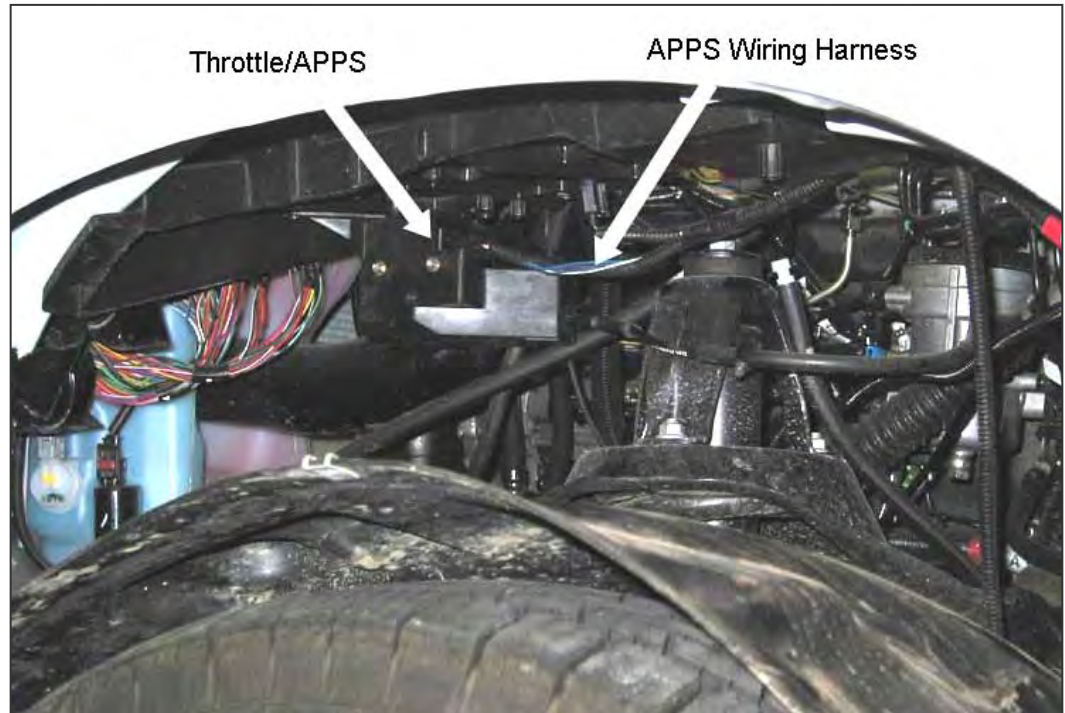

BD Engine Brake Inc.

Plant Address: Unit A10, 33733 King Rd, Abbotsford, BC, Canada V2S 7M9

U.S. Shipping Address: 88-446 Harrison St, Sumas, WA 98295 U.S. Mailing Address: P.O. Box 231, Sumas, WA 98295

Phone: 604-853-6096 Fax: 604-853-8749 Internet: www.bd-power.com

Switch Install (Required if using main toggle switch)

Remove attaching screws of the dashboard bezel and remove covering trim by pulling rearward on the corners of the trim panels.



Note: Placing the transmission all the way into 1st/low gear and ensuring the tilt steering is all the way down will allow for easy removal.

Pull the left hand and right hand dash panels away from their secured positions and let them hang.



Once the dash trim has been removed place it on a large working surface like a table or workbench.

Measure and mark a spot for the Toggle Switch 3/4" up from the bottom edge of the dash panel and 1" in from the left edge of the accessory panel as shown in the photo.

Drill a pilot hole with a 1/8" bit and finish by enlarging the hole with a Unibit to exactly 1/2".

NOTE: YOU MAY HAVE TO GRIND DOWN PART OF THE SUPPORT RIB ON THE BACK OF THE TRIM PANEL TO ACCOMMODATE THE SWITCH BODY.

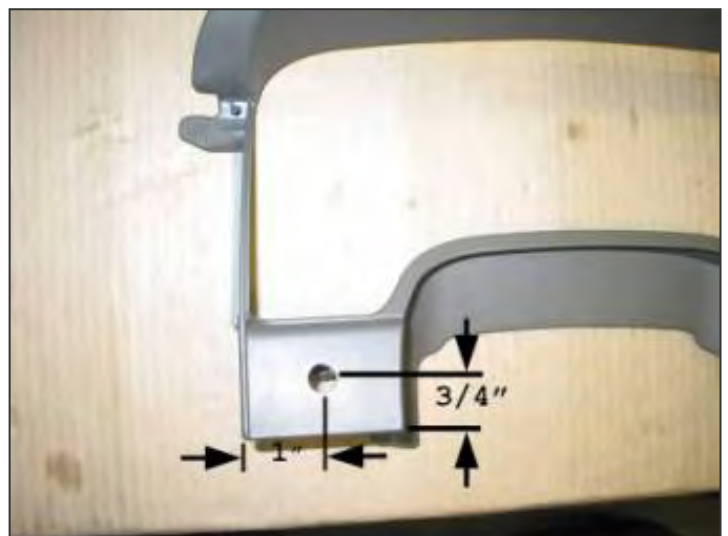

BD Engine Brake Inc.

Plant Address: Unit A10, 33733 King Rd, Abbotsford, BC, Canada V2S 7M9

U.S. Shipping Address: 88-446 Harrison St, Sumas, WA 98295 U.S. Mailing Address: P.O. Box 231, Sumas, WA 98295

Phone: 604-853-6096 Fax: 604-853-8749 Internet: www.bd-power.com



Install switch into drilled hole and secure with lock ring then reinstall dash trim panels by reversing the removal procedure.

Once the switch is installed, attach the ground wire to a good metal ground under the dash.

With a test light, locate a switched 12 Volt power source and install the supplied black (12-18ga) Posi-Tap™ to it then attach the red fused wire from the switch to this Posi-Tap™.

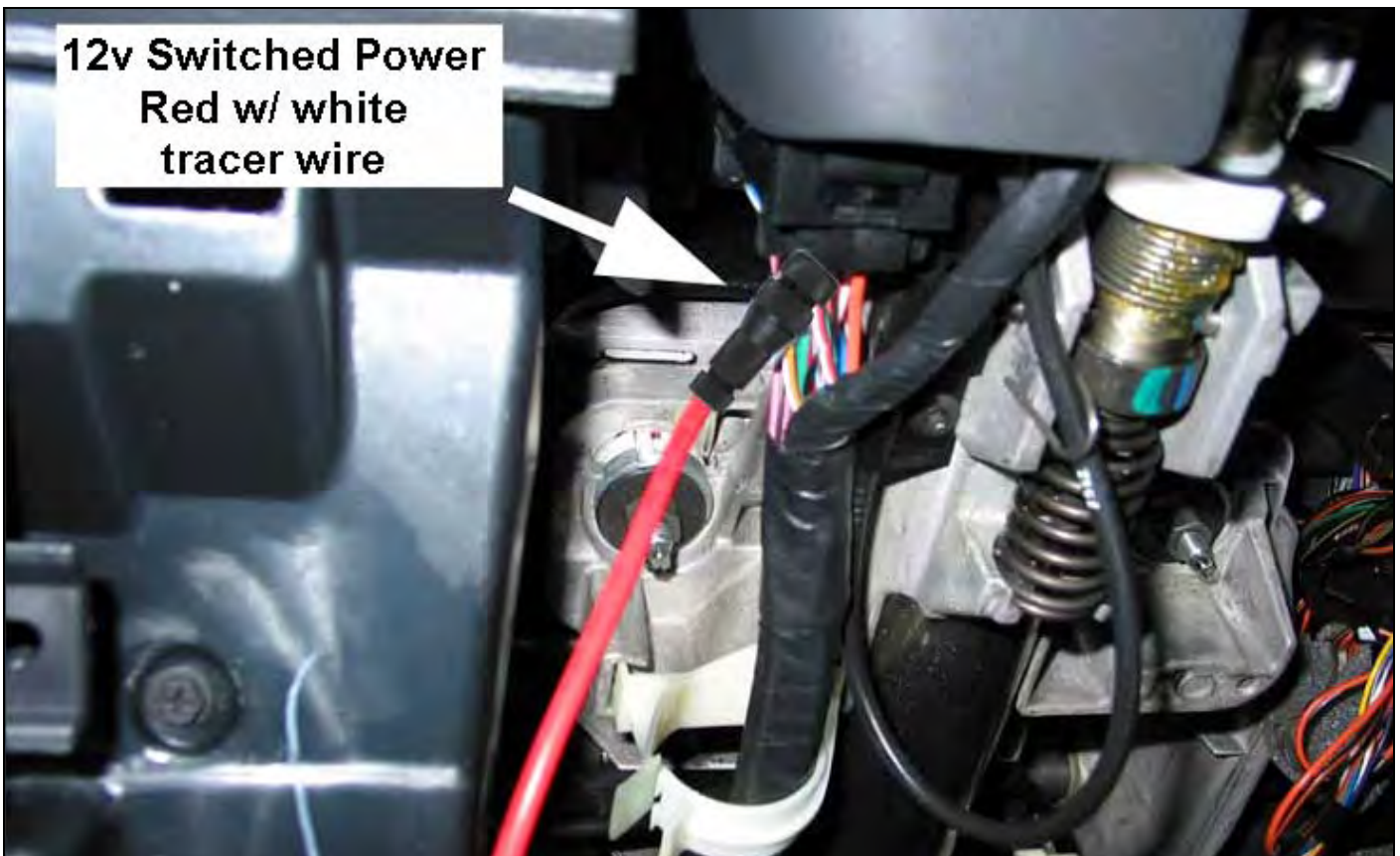

BD Engine Brake Inc.

Plant Address: Unit A10, 33733 King Rd, Abbotsford, BC, Canada V2S 7M9

U.S. Shipping Address: 88-446 Harrison St, Sumas, WA 98295 U.S. Mailing Address: P.O. Box 231, Sumas, WA 98295

Phone: 604-853-6096 Fax: 604-853-8749 Internet: www.bd-power.com

Brake Valve Installation (2003-2004)

***SAFETY*:** To prevent injury or damage raise the vehicle to a good working height and support with jack stands or axle stands.

From underneath the vehicle, remove 2 of the exhaust pipe hanger pins from front of the muffler allowing the rear section of the exhaust to hang down and provide access to the exhaust.

HINT: Spray WD40 on pins and slide the rubber hangers off.

Remove the exhaust clamp that holds the intermediate pipe to the down pipe at the first cross member.

Measure and mark the intermediate exhaust pipe approximately 7 1/4" from the end of the pipe and cut off.

Separate the cut intermediate pipe from the front pipe by splitting or cutting the side of the intermediate pipe, which will make it easier to remove.

CAUTION: BE CAREFUL NOT TO CUT TOO DEEPLY WHEN SPLITTING THE PIPE OR YOU WILL CUT THROUGH THE FRONT PIPE.

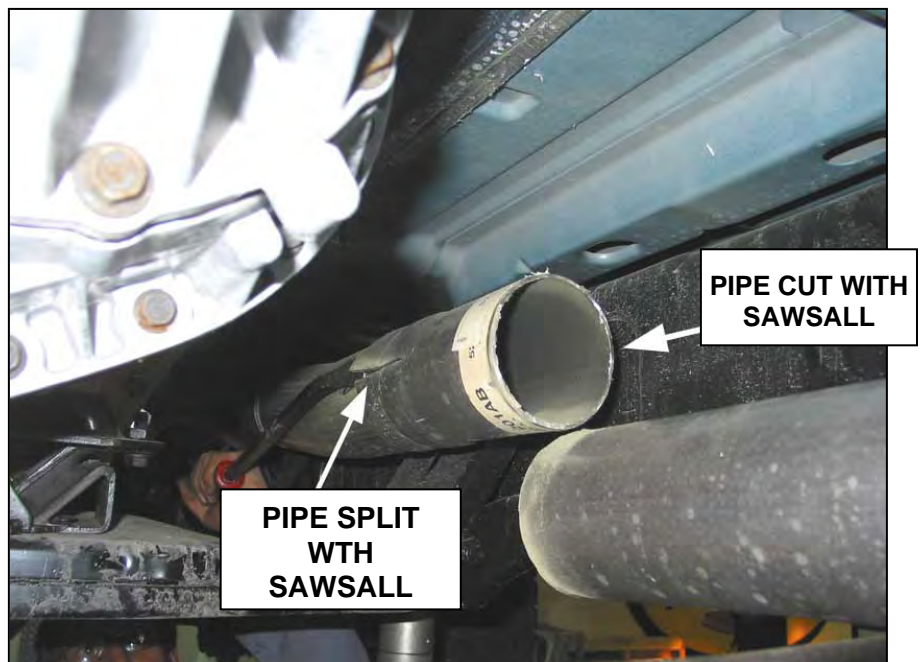
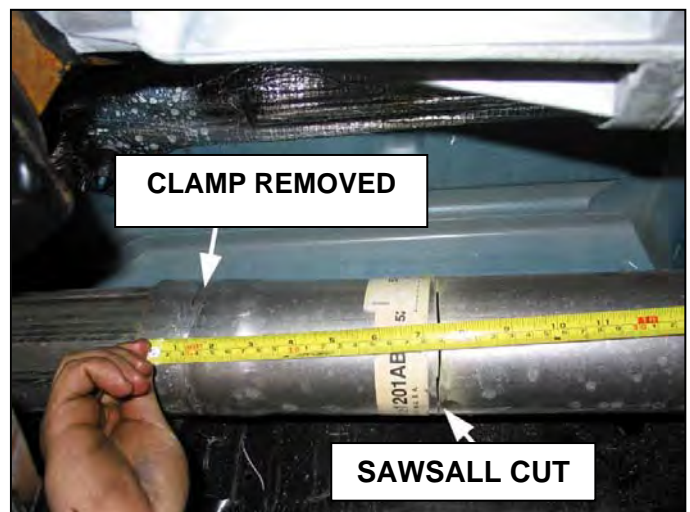

BD Engine Brake Inc.

Plant Address: Unit A10, 33733 King Rd, Abbotsford, BC, Canada V2S 7M9

U.S. Shipping Address: 88-446 Harrison St, Sumas, WA 98295 U.S. Mailing Address: P.O. Box 231, Sumas, WA 98295

Phone: 604-853-6096 Fax: 604-853-8749 Internet: www.bd-power.com

Clean off the cut ends of the intermediate pipe with a file to remove burrs left from cutting and then insert the adapter pipes onto each end of the now exposed pipes.

Insert the exhaust brake install with supplied 'V' band clamps. Be sure that the air cylinder bracket extends towards the rear of the vehicle.

Tighten all mounting nuts and bolts that secure the brake to the flanges.



Re-install the rubber exhaust hangers that were removed earlier and then check for proper exhaust alignment.



Ensure the exhaust brake and rear exhaust sections are pushed all the way forward on the front pipe so that the front adapter flange is up against the stop that is on top of the front pipe section then WELD the pipe in place.

NOTE: SECURING WITH JUST A HORSESHOE CLAMP WILL CAUSE LEAKAGE AND NOT ALLOW THE BRAKE TO OBTAIN FULL BRAKING PRESSURE.

BD Engine Brake Inc.

Plant Address: Unit A10, 33733 King Rd, Abbotsford, BC, Canada V2S 7M9

U.S. Shipping Address: 88-446 Harrison St, Sumas, WA 98295 U.S. Mailing Address: P.O. Box 231, Sumas, WA 98295

Phone: 604-853-6096 Fax: 604-853-8749 Internet: www.bd-power.com

Brake Valve Installation (2004-06)

***SAFETY*:** To prevent injury or damage raise the vehicle to a good working height with either a hoist or proper jack stands.

From underneath the vehicle, locate the turbo down pipe and the catalytic converter. You will need to cut a 7-1/4" section from this pipe. Although the pipe has a number of unusual bends, you will need to choose the straightest section possible, especially for the rear adapter of the brake, as this is a SS band clamp. As well mock up the installation of the brake so that when the brake cycles, the actuator will not come in contact with anything. Use a Sawsall or cutting disc to remove this section.

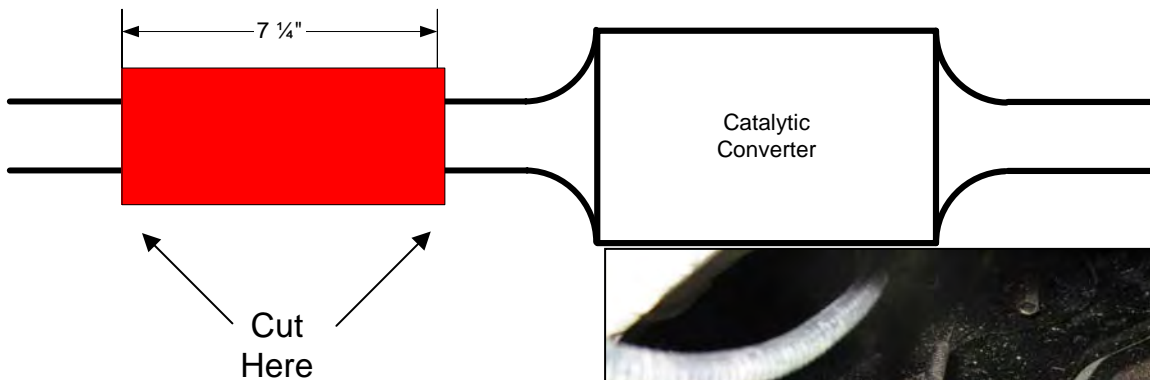

Clean off the cut ends of the intermediate pipe with a file to remove burrs left from cutting and then insert the adapter pipes onto each end of the now exposed pipes.

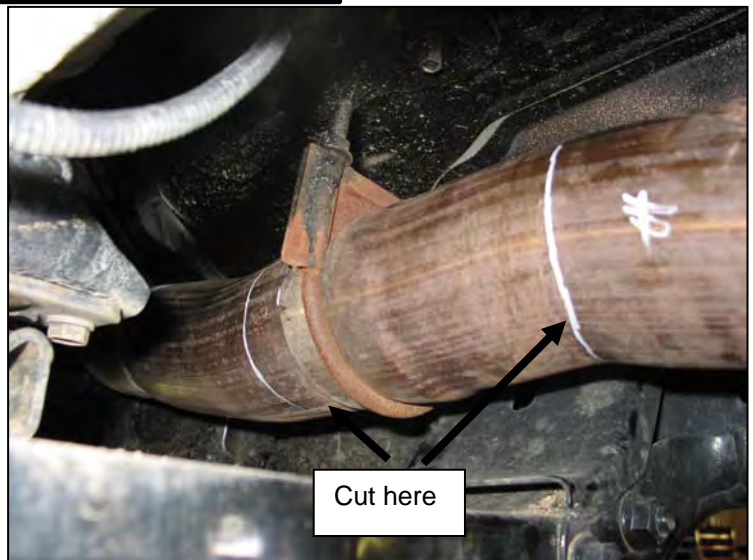

Insert the exhaust brake install with supplied 'V' band clamps. Be sure that the air cylinder bracket extends toward the rear of the vehicle.



Tighten all mounting nuts and bolts that secure the brake to the flanges.

BD Engine Brake Inc.

Plant Address: Unit A10, 33733 King Rd, Abbotsford, BC, Canada V2S 7M9

U.S. Shipping Address: 88-446 Harrison St, Sumas, WA 98295 U.S. Mailing Address: P.O. Box 231, Sumas, WA 98295

Phone: 604-853-6096 Fax: 604-853-8749 Internet: www.bd-power.com

Ensure the exhaust brake and rear exhaust sections are pushed all the way forward on the front pipe so that the front adapter flange is up against the stop that is on top of the front pipe section then WELD the pipe in place. Install the clamp on the rear exhaust adapter.

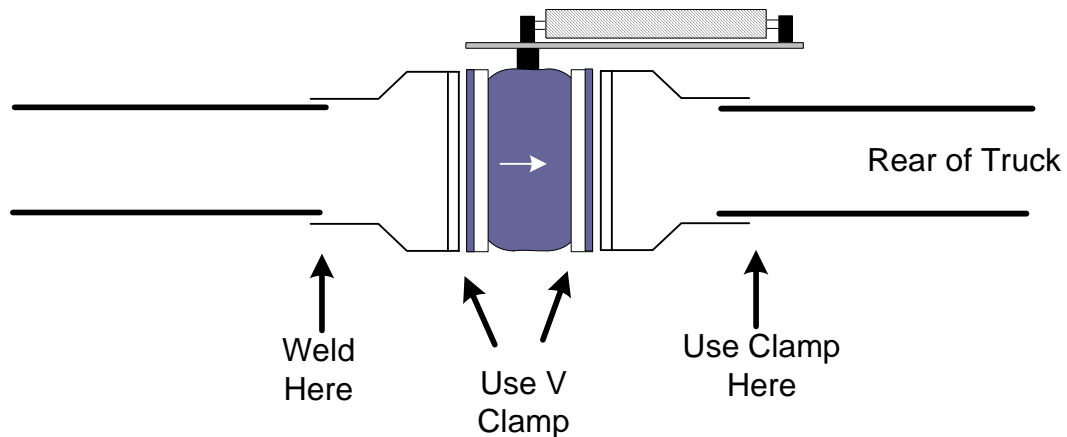

NOTE: SECURING WITH JUST A HORSESHOE CLAMP WILL CAUSE LEAKAGE AND NOT ALLOW THE BRAKE TO OBTAIN FULL BRAKING PRESSURE.

BD Engine Brake Inc.

Plant Address: Unit A10, 33733 King Rd, Abbotsford, BC, Canada V2S 7M9

U.S. Shipping Address: 88-446 Harrison St, Sumas, WA 98295 U.S. Mailing Address: P.O. Box 231, Sumas, WA 98295

Phone: 604-853-6096 Fax: 604-853-8749 Internet: www.bd-power.com

Air Solenoid Installation

Just across from the exhaust brake on the passenger side frame rail you will notice a number of factory holes in the frame. You will need to mount the air solenoid assembly on the inside of the frame rail utilizing one of these holes. Make sure that the air solenoid assembly is as close as possible to the exhaust brake to ensure a quick engagement and disengagement of the valve.



Air Hose Installation

Once the brake, pump, regulator & air solenoid assemblies are installed in their correct positions, insert one end of the 1/4" plastic hose (9' is included in the control kit) into the quick release valve that is mounted on top of the air cylinder and route it to the air solenoid you mounted on the frame rail. This hose may need to be cut for a custom fit. If so, make sure that it is a STRAIGHT cut, leaving no burrs or angled pieces on the end of the hose. If it cut improperly, it may not seal properly, causing a leak. Insert the open end of the plastic tubing into the "CYL" connection on the air solenoid.

As indicated by the photo, secure the plastic hose by installing one of the clamps provided to the body of the cab. Drill a 1/8" pilot hole in the cab body, as shown in the photo. Install the second anchor clamp securing with a self-tapping screw.



CARE MUST BE TAKEN NOT TO KINK THE PLASTIC HOSE OR ROUTE IT NEAR A HEAT SOURCE.

BD Engine Brake Inc.

Plant Address: Unit A10, 33733 King Rd, Abbotsford, BC, Canada V2S 7M9

U.S. Shipping Address: 88-446 Harrison St, Sumas, WA 98295 U.S. Mailing Address: P.O. Box 231, Sumas, WA 98295

Phone: 604-853-6096 Fax: 604-853-8749 Internet: www.bd-power.com

NOTE: Removal of the plastic hose from the quick coupler is accomplished by pushing the colored ring toward the fitting and pulling the hose out.

REFER TO THE WIRING DIAGRAM PAGE 19 FOR CORRECT HOOK UP OF HOSES AND WIRING.

Included in the kit is a snorkel relocation kit. It has two sections of air tubing, along with a red wire to trigger the air solenoid.



Locate the section of tubing in the harness that has no fittings on it. Plug one end of the tube into the air solenoid marked "In". Connect the red 14ga wire (with the female butt connector end) into the power (red) connection at the air solenoid.

Locate the other section of tubing in the harness with an open end (the other end has the yellow snorkel filter on it). Plug the open end into the brake's 90° quick-connect fitting located at the end of the air cylinder.

Run the harness along the bottom of the truck and up towards the engine compartment in a clean, dry location, securing it away from any moving or heated parts.

In the engine compartment, connect the open ended section of tubing (the other end that was plugged into the "In" connection at the air solenoid) and route it to the regulator assembly. Insert it into the straight quick-connect fitting that is hooked into the regulator. Push firmly to ensure a full connection is made.

Cut any excess slack from the red wire (that was plugged into the power of the air solenoid), crimp on a female bullet connector fitting, and connect it to the red output wire located in the control kit harness.

The section of tubing with the yellow snorkel filter should be routed into the cab of the truck to avoid any moisture or condensation from entering the filter.

Reference the installation diagram on the next page for an example.

BD Engine Brake Inc.

Plant Address: Unit A10, 33733 King Rd, Abbotsford, BC, Canada V2S 7M9

U.S. Shipping Address: 88-446 Harrison St, Sumas, WA 98295 U.S. Mailing Address: P.O. Box 231, Sumas, WA 98295

Phone: 604-853-6096 Fax: 604-853-8749 Internet: www.bd-power.com

Wiring & Plumbing Diagram

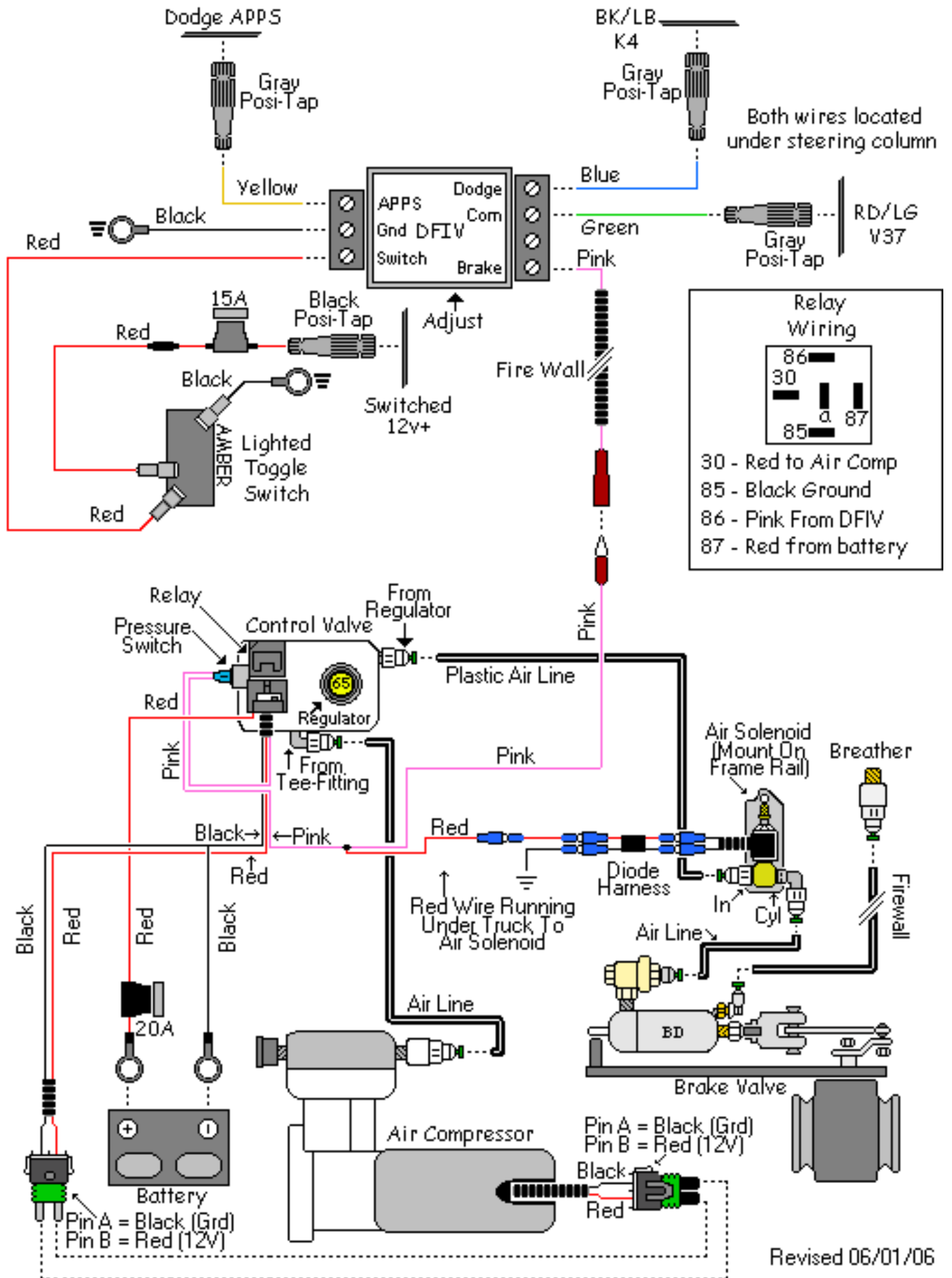

BD Engine Brake Inc.

Plant Address: Unit A10, 33733 King Rd, Abbotsford, BC, Canada V2S 7M9

U.S. Shipping Address: 88-446 Harrison St, Sumas, WA 98295 U.S. Mailing Address: P.O. Box 231, Sumas, WA 98295

Phone: 604-853-6096 Fax: 604-853-8749 Internet: www.bd-power.com

DFIV Adjustment & Testing

Ensure the connections of the corresponding wires to the DFIV Control Module are correct as shown in the wiring diagram.

To achieve the correct setting for the activation of the exhaust brake in relation to the throttle pedal the DFIV Module must be calibrated for your vehicle.

With the throttle at idle, start the engine and turn on brake switch. Then, using a small flat bladed screwdriver, turn the small adjusting screw in the DFIV Module counterclockwise or clockwise until the pump/brake JUST turns on.



CAUTION: THE ADJUSTING SCREW IS A MICRO-SWITCH THAT IS VERY DELICATE, SO TURN USING SMALL ADJUSTMENTS.

Test by revving up the engine to approximately 1200 RPM and releasing the throttle. As the accelerator pedal is applied the brake should disengage just before then engine starts to rev, indicating proper calibration of the DFIV Module with the APPS.

Then the brake should activate again when the throttle pedal returned to idle. If not, readjust the DFIV Module so that it does.

Check for any exhaust leaks and recheck all connections and hoses for security and interference from moving or heated items. After about 100 miles (160 km), re-torque the flange bolts.

BD Engine Brake Inc.

Plant Address: Unit A10, 33733 King Rd, Abbotsford, BC, Canada V2S 7M9

U.S. Shipping Address: 88-446 Harrison St, Sumas, WA 98295 U.S. Mailing Address: P.O. Box 231, Sumas, WA 98295

Phone: 604-853-6096 Fax: 604-853-8749 Internet: www.bd-power.com

Notes On Connectors

The kit includes a number of Posi-Tap™ connectors (Gray or Red/Black/Green or Yellow) to tap onto OEM wiring. It is important to select the correct color of connector so that it matches the gauge of the OEM wire that it is being installed on. Using the incorrect connector could cause an inadequate connection and/or the OEM wire could be severed.

OEM Wire	Posi-Tap™ Color
18-22ga	Gray or Red
12-18ga	Black
10-12ga	Green or Yellow

Though these connectors offer a quicker installation, the best option would be to solder the wires and isolate the joints with heat shrink or liquid electrical tape. Proper soldering techniques should be used to ensure adequate connections.

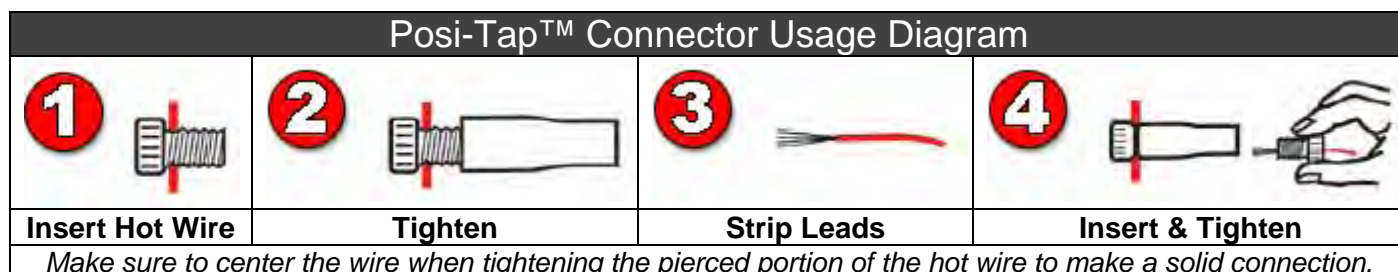

The ground terminals of the vehicle’s batteries should be disconnected before performing any piercing/posi-tapping onto any ECM/PCM wire.

BD Engine Brake Inc.

Plant Address: Unit A10, 33733 King Rd, Abbotsford, BC, Canada V2S 7M9

U.S. Shipping Address: 88-446 Harrison St, Sumas, WA 98295 U.S. Mailing Address: P.O. Box 231, Sumas, WA 98295

Phone: 604-853-6096 Fax: 604-853-8749 Internet: www.bd-power.com

Optional Manual Shifter Switch (Push-Pull Style)

Mount the shifter switch onto the shift lever using the clamp supplied (either 5/8" or 3/4"). Run the electrical cable down the shifter shaft, securing the cable with zip-ties or electrical tape, and run it under the carpet to the firewall and under the dash to the relays, leaving enough slack for proper shifting of the transmission lever and to prevent any rubbing of wire.

At the end of the cable, cut off any excess and strip away about 1 to 2 inches of the black rubber covering exposing the black and white (or green) wires then strip the insulation from the ends of the two wires.



Connect the white (or green) wire to the "Switch" terminal on the DFIV.

Attach a male blade connector to the black wire. Remove the fused red wire from the toggle switch (the toggle switch and remaining red and black wire attached to the switch will no longer be needed) and attach to the black wire from the optional switch to the female connector of the fused Red wire from the toggle switch.

Locate one of the ignition switched red/black tracer wires under the steering column (one is 10/12ga and the other is 14/16ga) and connect an appropriate Posi-Tap connector to it (green for 10/12ga and black for the 14/16ga wire) then connect the fused red wire to this Posi-Tap.

BD Engine Brake Inc.

Plant Address: Unit A10, 33733 King Rd, Abbotsford, BC, Canada V2S 7M9

U.S. Shipping Address: 88-446 Harrison St, Sumas, WA 98295 U.S. Mailing Address: P.O. Box 231, Sumas, WA 98295

Phone: 604-853-6096 Fax: 604-853-8749 Internet: www.bd-power.com

Optional Manual Shifter Switch (Rocker Switch Style)

Mount the shifter switch onto the shift lever using the clamp supplied (either 5/8" or 3/4"). Run the electrical cable down the shifter shaft, securing the cable with zip-ties or electrical tape, and run it under the carpet to the firewall and under the dash to the relays, leaving enough slack for proper shifting of the transmission lever and to prevent any rubbing of wire.

At the end of the cable, cut off any excess and strip away about 1-2" of the black rubber insulation exposing the black, white and green wires, then strip the insulation from the ends of the three wires.

Connect the green 12V output green wire to the "Toggle Switch" input terminal on the DFIV.

Attach the 5/16" ring connector to the black ground wire and attach it to a good ground nearby.

Locate one of the ignition switched power fuses in the fuse panel underneath the steering column. Use the supplied fuse tap to supply ignition switched power to the "Keyed 12 Volts" (white) wire of the rocker switch assembly.

Also provided in the kit is a Posi-Tap connector as an alternative to the fuse tap and flag connector. If you want to use the Posi-Tap instead of using the fuse tap in the fuse panel, then you will need to locate a 12V switched ignition wire to power the switch. You could also use the 12V Switched Power source that powers the DFIV.

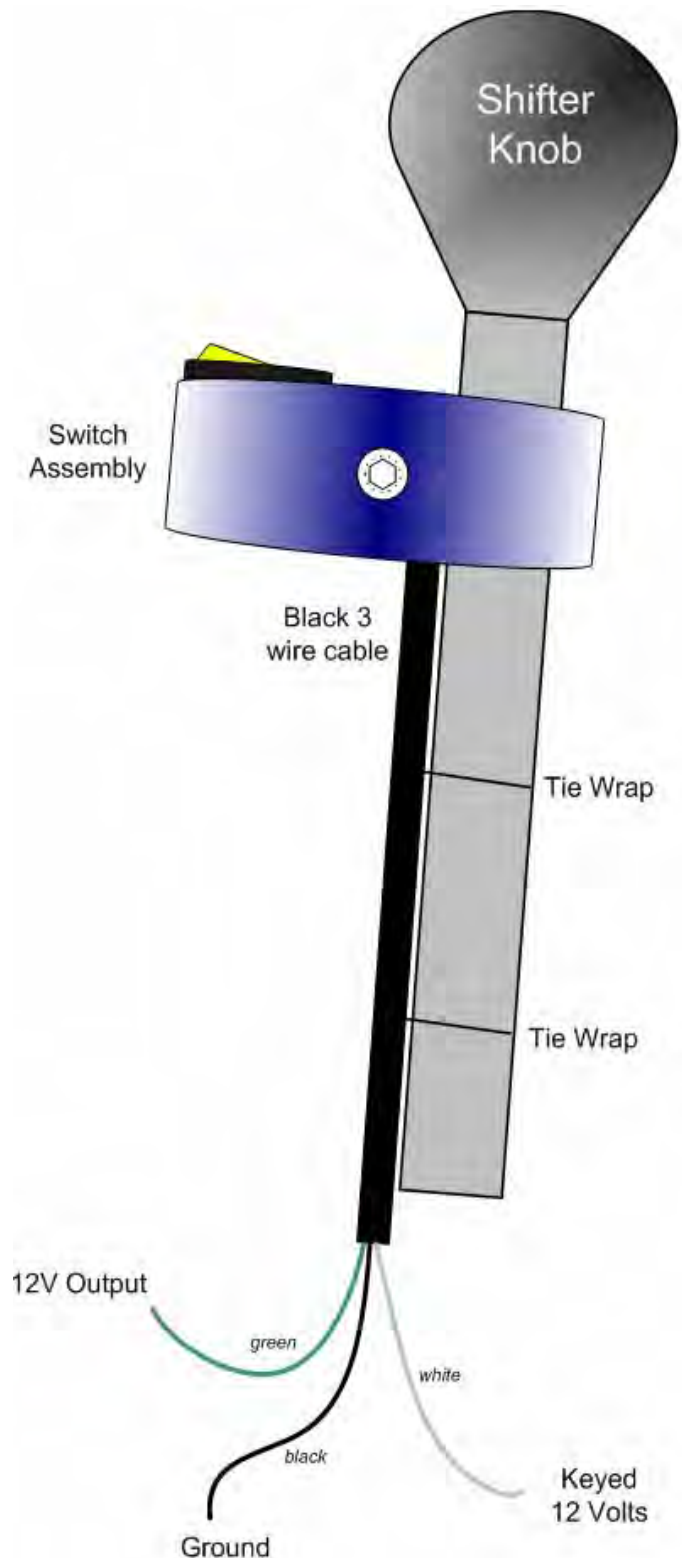

BD Engine Brake Inc.

Plant Address: Unit A10, 33733 King Rd, Abbotsford, BC, Canada V2S 7M9

U.S. Shipping Address: 88-446 Harrison St, Sumas, WA 98295 U.S. Mailing Address: P.O. Box 231, Sumas, WA 98295

Phone: 604-853-6096 Fax: 604-853-8749 Internet: www.bd-power.com

Idle Pressure Adjustment

Exhaust Brake pressure is preset at the factory but if more holdback performance is required with the vehicle loaded, adjust the regulator using small increments to give 50 – 55psi under load.

Test the exhaust brake pressure by installing a pressure gauge into the test port on the bottom of the brake valve, if pressure is not 15 - 17psi at idle the pressure will need to be adjusted for the vehicle.

Turn on key but DO NOT START engine and turn brake switch ON.

On the brake assembly, loosen the 9/16" lock nut and back the stop bolt AWAY from the actuating lever.

Cycle the brake ON and OFF at least once and then leave brake ON.

Turn the bolt to touch the actuating lever plus 1 flat more then tighten the lock nut.

Start the engine and check the backpressure, if pressure is ABOVE 17psi, loosen the lock nut and turn the bolt in 1 additional flat.

CAUTION: Backing the stop bolt all the way to allow the actuating arm to go all the way forward will cause the butterfly valve to contact the wall of the brake housing causing damage to the brake and warranty will be voided.

The maximum REGULATED pressure is adjusted with the pressure regulator under the hood and under driving conditions.

Turning the regulator **clockwise** will increase pressure.

Turning the regulator **counter clockwise** will decrease pressure.

*****DO NOT EXCEED 65# REGULATED BACK PRESSURE*****

BD Engine Brake Inc.

Plant Address: Unit A10, 33733 King Rd, Abbotsford, BC, Canada V2S 7M9

U.S. Shipping Address: 88-446 Harrison St, Sumas, WA 98295 U.S. Mailing Address: P.O. Box 231, Sumas, WA 98295

Phone: 604-853-6096 Fax: 604-853-8749 Internet: www.bd-power.com

Maintenance & Troubleshooting

To extend life of the exhaust brake, do not operate the vehicle for extended periods of time without activating the brake. We suggest activating the exhaust brake at least a couple times a day while operating the vehicle to prevent any carbon or rust build up on inner parts of the brake valve assembly.

The hoses, wires, fittings and clamps should be inspected on a regular basis for any deterioration, damage or leaks.

To increase the life of your exhaust brake, we recommend daily operation. By simply switching the brake on and off a couple times a day, it will prevent the butterfly valve from sticking due to carbon build-up.

Following the diagrams in this manual, tracing hoses and wiring, checking continuity through electric components or checking for any lines that are disconnected, should solve any problems that may arise. If you have any problems or need replacement parts, call us at 1-800-887-5030, between 8:30am and 5:00pm Pacific Time.

Operating Guidelines

Thank you for taking interest in the BD Engine Exhaust Brake. As a driver, you probably already know the need for extra braking power that your vehicle requires on the hills and long grades. With loads being towed behind you, the extra push when slowing down or maintaining speed on downward grades can prove to be a great strain on your vehicles hydraulic braking system, even to the point of "burn-up". These guidelines were designed to offer you a better understanding of the benefits of exhaust brakes and are partly based upon material developed by the U.S. Department of Transportation National Highway Traffic Safety Administration.

The emphasis on today's vehicles is to give the consumer a product that can give them usable power with fuel efficiency. But, in the transition, the vehicles have lost their natural braking power, making it more easy for the vehicle to continue to roll and harder to stop. Of course, this gets more noticeable with the increase of weight, on or behind the vehicle. This is where an exhaust brake becomes a useful tool in increasing the driveline drag of the vehicle without the use of the hydraulic brakes; a tool that with maximum use or even occasional use can reduce wear on hydraulic braking parts and at the same time increase safety.

The BD Exhaust Brake can be used to help maintain a controlled vehicle speed on a downward grade, as well as slowing the vehicle down for such times as turns or exit ramps, without you using your hydraulic brakes. **But, the exhaust brake cannot be used as a parking brake or will not bring your vehicle to a complete stop.** By using a BD Exhaust Brake, the life and effectiveness of your hydraulic brakes will increase.

BD Engine Brake Inc.

Plant Address: Unit A10, 33733 King Rd, Abbotsford, BC, Canada V2S 7M9

U.S. Shipping Address: 88-446 Harrison St, Sumas, WA 98295 U.S. Mailing Address: P.O. Box 231, Sumas, WA 98295

Phone: 604-853-6096 Fax: 604-853-8749 Internet: www.bd-power.com

This is because of the decreased use of the hydraulic brakes in situations like hills, the wear factor is reduced and there is less opportunity for your hydraulic brakes to heat up which would reduce the efficiency. When you ride your hydraulic brakes, make hard stops or have poorly adjusted brakes, this creates high temperatures and as your brakes get hotter, the more chance there is for failure.

With terrain that is a series of up and down grades, the BD Exhaust Brake will help reduce warping in the exhaust valves. Because of the power needed to pull your vehicle and load up a hill, this generates a lot of heat. When you have reached the crest of the hill and are coasting down the other side, the heated valves are cooled too quickly. With the exhaust brake engaged, the heat loss to the valves will be reduced, which can prevent valve warping.

When the toggle switch is turned to the "On" position, the valve is activated every time the driver takes his foot off of the throttle pedal. When the driver puts pressure back on the throttle pedal, the DFIV/switch is deactivated and the valve opens again.

Exhaust brakes are designed to operate with the throttle at idle - not to be used in conjunction with cruise controls, and not designed to aid in gear shifting.

Such cases may cause damage to engine and/or exhaust brake. There is a pressure regulating system incorporated with the BD Exhaust Brake that will control the created backpressure. If the backpressure reaches the set limit while under engine braking, the exhaust valve will open slightly to relieve the excess pressure.

The best scenario for exhaust braking is when going down hill, select a gear that lets you maintain a constant speed with little or no use of the hydraulic brakes, or the same gear that would be used to go up the same grade of hill. This also depends on the weight, load or road conditions that the vehicle will come upon. So, in summary, by using the BD Exhaust Brake, you reduce the need for use of your hydraulic brakes in situations where you need to slow down or maintain (i.e. hills, off ramps, corners, approaching speed changes or traffic lights). Reducing the use of your hydraulic brakes in these situations will reduce the heat build up, as well as wear and damage to linings and drums. And, when you reduce these factors, you save your hydraulic brakes for when you really need them (for stopping or emergencies).

The BD Exhaust Brake is not a substitute for your hydraulic brakes and, cannot correct or compensate for poorly maintained or misadjusted brakes. But, when you need to slow down or maintain a constant speed, the BD Exhaust Brake will be a valuable and effective tool. Exhaust Brakes are more efficient at preventing rather than correcting an over speed condition.

Thank you and happy motoring.
BD Engine Brake, Inc.

BD Engine Brake Inc.

Plant Address: Unit A10, 33733 King Rd, Abbotsford, BC, Canada V2S 7M9

U.S. Shipping Address: 88-446 Harrison St, Sumas, WA 98295 U.S. Mailing Address: P.O. Box 231, Sumas, WA 98295

Phone: 604-853-6096 Fax: 604-853-8749 Internet: www.bd-power.com

BD Engine Brake, Inc. *Limited Warranty Statement*

THE INSTALLATION OF THIS PRODUCT INDICATES THAT THE BUYER HAS READ AND UNDERSTANDS THIS AGREEMENT AND ACCEPTS ITS TERMS AND CONDITIONS.

DISCLAIMER OF LIABILITY

BD Engine Brake Inc., its successors, distributors, jobbers, and dealers (hereafter "BD") shall in no way be responsible for the product's proper use and service. **THE BUYER HEREBY WAIVES ALL LIABILITY CLAIMS.**

BD disclaims any warranty and expressly disclaims any liability for personal injury or damages. **BD** also disclaims any liability for incidental or consequential damages including, but not limited to, repair labor, rental vehicles, hotel costs, or any other inconvenience costs by reason of use or sale of any such equipment. The **BUYER** acknowledges and agrees that the disclaimer of any liability for personal injury is a material term for this agreement and the **BUYER** agrees to indemnify **BD** and to hold **BD** harmless from any claim related to the item of any equipment purchased.

This warranty shall not apply to any unit that has been improperly stored or installed, or to misapplication, improper operation conditions, accidents, neglect, or which has been improperly repaired or altered or otherwise mistreated by the **BUYER** or his agent. **BD** also assumes no liability regarding the improper installation or misapplication of its products. It is the installer's responsibility to check for proper installation and if in doubt, contact the manufacturer.

LIMITATION OF WARRANTY

BD Engine Brake Inc. (hereafter "BD") warrants to the **BUYER** that any parts purchased shall be free from defects in material workmanship. A defect is defined as a condition within the product that would render the product inoperable. **BD** gives Limited Warranty as to description, quality, merchantability, fitness for any product's purpose, productiveness, or any other matter of **BD's** product sold herewith. **BD** shall be in no way responsible for the product's open use and service and the **BUYER** hereby waives all rights other than those expressly written herein. This Warranty shall not be extended or varied except by a written instrument signed by **BD** and the **BUYER**.

This Warranty is Limited to two (2) years from the date of sale. Labor costs incurred by the removal and replacement of the BD product, while performing warranty work, will be covered for 1 (one) year, payable at BD rates, at authorized centers and with prior approval. Until BD has approved the claim, the consumer may be responsible for these costs.

A Return Authorization (WA) number, obtained in advance from **BD**, must accompany all products returned for warranty consideration. All products must be returned, shipping prepaid, to **BD** and must be accompanied by a dated proof of purchase receipt. All Warranty claims are subject to approval by **BD** and repaired or replaced product will be returned to the customer freight collect. Accepted warranty units, which have been replaced, become the sole property of **BD**.

This warranty is in lieu of all other warranties or guaranties, either expressed or implied, and shall not extend to any consumer or to any person other than the original purchaser residing within the boundaries of the continental U.S. or Canada.

IN THE EVENT THAT THE BUYER DOES NOT AGREE WITH THIS AGREEMENT, THE BUYER MAY PROMPTLY RETURN THIS PRODUCT, IN A NEW AND UNUSED CONDITION, WITH A DATED PROOF OF PURCHASE, TO THE PLACE OF PURCHASE WITHIN THIRTY (30) DAYS FROM DATE OF PURCHASE FOR A FULL REFUND.

BD Engine Brake Inc.

Plant Address: Unit A10, 33733 King Rd, Abbotsford, BC, Canada V2S 7M9

U.S. Shipping Address: 88-446 Harrison St, Sumas, WA 98295 U.S. Mailing Address: P.O. Box 231, Sumas, WA 98295

Phone: 604-853-6096 Fax: 604-853-8749 Internet: www.bd-power.com