

BD VALVE BODY

For 2005-2006 Dodge 5.9L 24V Cummins Trucks
-- Installation Instructions --

	1030421	2005 Dodge 24V	48RE
	1030423	2006 Dodge 24V	48RE

IMPORTANT – READ ALL INSTRUCTIONS BEFORE INSTALLATION.

BD Engine Brake, Inc.

Plant Address: Unit A10, 33733 King Rd, Abbotsford, BC, Canada V2S 7M9

U.S. Shipping Address: 88-446 Harrison St, Sumas, WA 98295 U.S. Mailing Address: P.O. Box 231, Sumas, WA 98295

Phone: 604-853-6096 Fax: 604-853-8749 Internet: www.bd-power.com

Tools Required

- Inch Pound Torque Wrench
- 3/8" or 1/2" Dr Socket sets including 11mm & 13mm socket
- #25 Torx Bit
- Combination Wrench Set including 7/16" & 3/4"
- 3/16" Allen wrench
- High Quality Pressure Gauge (0 - 160 psi)
- Voltmeter

Additional Parts Required (Not Included)

- Type PLUS 3 ATF (Recommended)
- 2 Bottles of Red Lubeguard (Recommended)

All Diesel Rams should be tested prior to engine or transmission performance tuning. Check transmission oil level prior to all work. Pressure testing will produce test results that can help to determine the ability of the transmission to prevent the clutch surfaces from slipping. Slippage will result in premature convertor and transmission wearing characteristics (soft or severe shifting, high transmission temperature).

2800-3000RPM (Wide Open Throttle)	Ensure shift points are correct before recording the pressures. Transmission should be at operating temperature.
-----------------------------------	--

48RE Transmissions

Transmission Line Pressure	OEM Pressure	BD Pressure	Test #1	Test #2
Transmission in DRIVE w/Engine at idle	55-65psi	70-75psi		

Transmission Shift Points

Transmission Shift Point (RPM)	Before	After
2 nd – 3 rd Shift point (Normal Driving)		
2 nd – 3 rd Shift point (Wide Open Throttle)		

IMPORTANT – IF PRESSURES AND/OR SHIFT POINTS ARE NOT TO SPEC, THE TRANSMISSION MUST BE REPAIRED OR SERVICED BEFORE MODIFICATIONS.

BD Engine Brake, Inc.

Plant Address: Unit A10, 33733 King Rd, Abbotsford, BC, Canada V2S 7M9

U.S. Shipping Address: 88-446 Harrison St, Sumas, WA 98295 U.S. Mailing Address: P.O. Box 231, Sumas, WA 98295

Phone: 604-853-6096 Fax: 604-853-8749 Internet: www.bd-power.com

Installation

1. Pressure testing is accomplished by inserting a fitting and hose assembly with a good quality gauge into the center 1/8" port on the passenger side of the transmission. Leave the gauge attached for testing later.
2. **VERY IMPORTANT** – Road test with gauge in place and record pressures and shift point RPM's **BEFORE** modifications are carried out to determine the condition of the transmission prior to installing this valve body. **Pressure will only be indicated with transmission in Drive position.**
3. Secure the vehicle with wheel chocks and place the transmission in Neutral.
4. Ensure the valve body has not been damaged in shipping and it is the proper part number for your vehicle.
5. Starting at the transmission, remove the shift cable from the manual lever.
6. Rotate the shift lever to the rear of the vehicle to place the transmission in the PARK position.

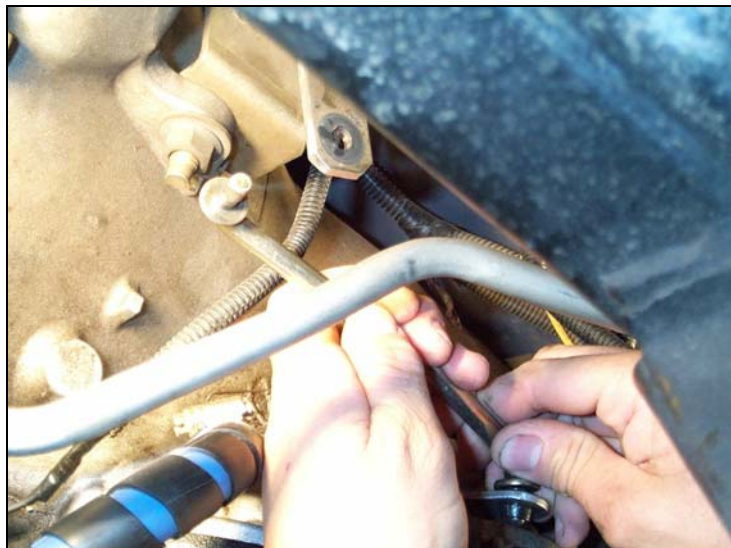

BD Engine Brake, Inc.

Plant Address: Unit A10, 33733 King Rd, Abbotsford, BC, Canada V2S 7M9

U.S. Shipping Address: 88-446 Harrison St, Sumas, WA 98295 U.S. Mailing Address: P.O. Box 231, Sumas, WA 98295

Phone: 604-853-6096 Fax: 604-853-8749 Internet: www.bd-power.com

7. Remove the two (2) bolts holding the TTVA motor to the transmission case.
8. Allow the TTVA to rotate clockwise away from the transmission.

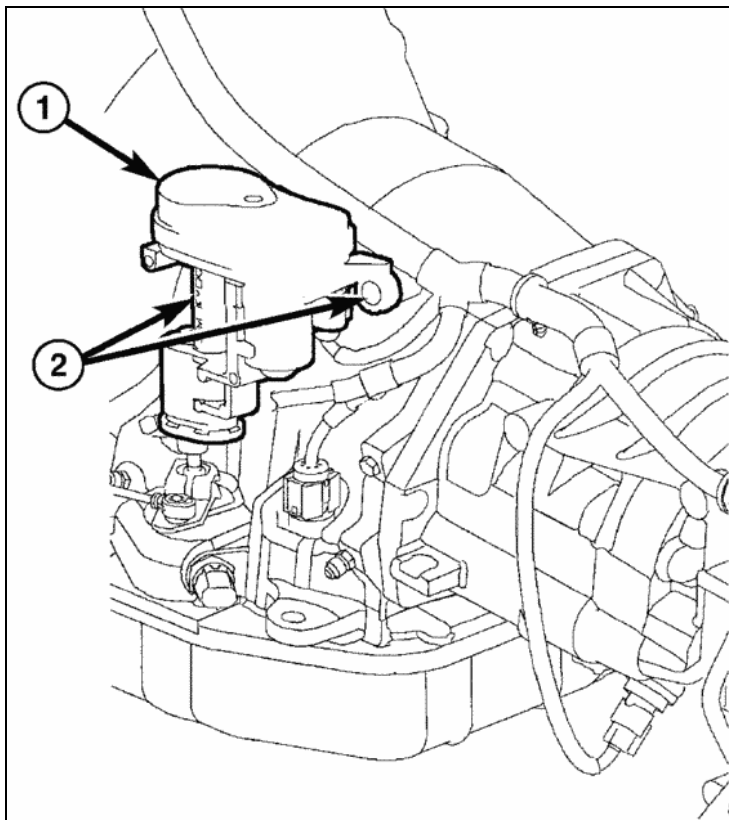

9. Remove the wiring connector (#2) from the TTVA.
10. Lift the TTVA straight upward and off of the throttle valve shaft.

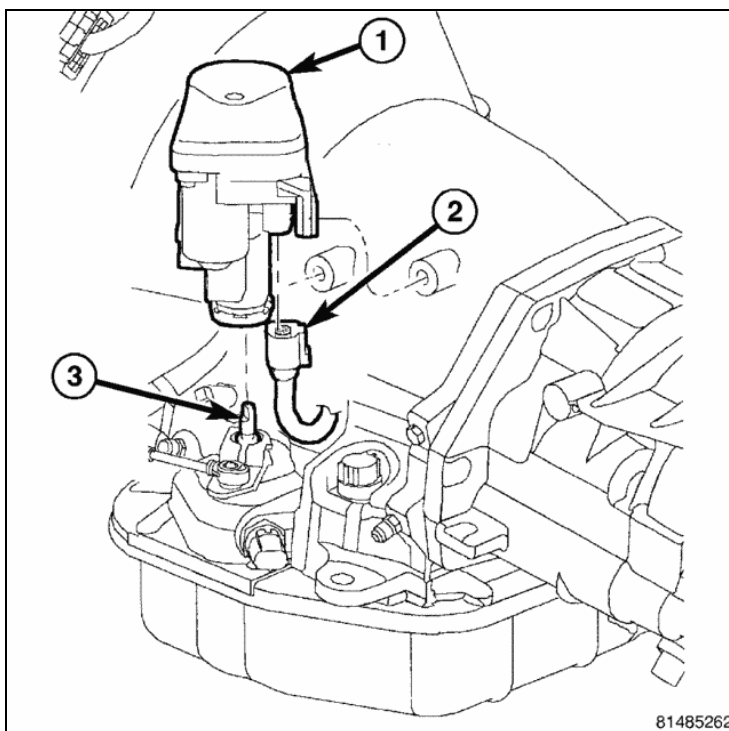

81485262

BD Engine Brake, Inc.

Plant Address: Unit A10, 33733 King Rd, Abbotsford, BC, Canada V2S 7M9

U.S. Shipping Address: 88-446 Harrison St, Sumas, WA 98295 U.S. Mailing Address: P.O. Box 231, Sumas, WA 98295

Phone: 604-853-6096 Fax: 604-853-8749 Internet: www.bd-power.com

11. Loosen the shift lever bolt, and then rotate the lever towards the front of the truck shifting the transmission into 1st / LOW position. This allows for the removal of the Park Rod E-clip without dropping the valve body.

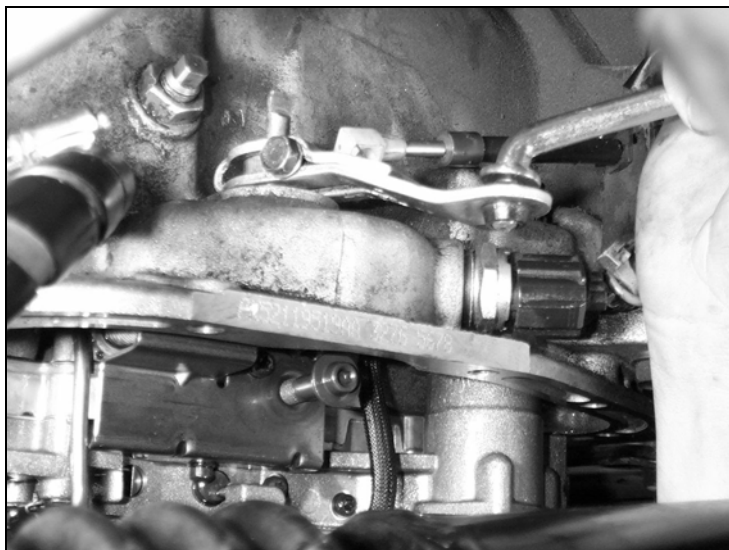

12. Remove the shift lever.

13. Disconnect the wiring connectors from the Neutral Safety switch and Valve Body then remove the Neutral Safety switch from the transmission.

14. Install a large drain pan under transmission, remove the oil pan, drain the transmission oil and then remove the filter.

15. Carefully remove the E-clip from the park rod, leaving the park rod in the transmission.

16. Remove the 10 valve body bolts, remembering the location of the different bolts. **Attaching bolts are different lengths and MUST be reinstalled in the proper location.**

17. When lowering the valve body, gently work it around so that the park rod lever is left in the transmission and ensure the electrical plug is not damaged in the removal process.

18. **CAUTION** - As you lower the valve body, watch for the accumulator piston and spring falling out.

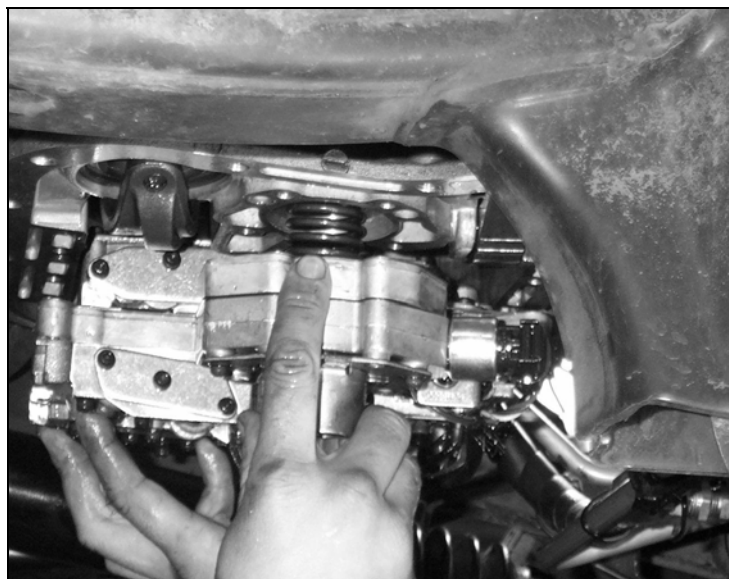

BD Engine Brake, Inc.

Plant Address: Unit A10, 33733 King Rd, Abbotsford, BC, Canada V2S 7M9

U.S. Shipping Address: 88-446 Harrison St, Sumas, WA 98295 U.S. Mailing Address: P.O. Box 231, Sumas, WA 98295

Phone: 604-853-6096 Fax: 604-853-8749 Internet: www.bd-power.com

19. This is the time to change the 2nd gear band strut to the heavy duty one we supply. First loosen the band adjusting screw lock nut with a 3/4" wrench, and then unscrew adjuster until the stock strut can be removed.

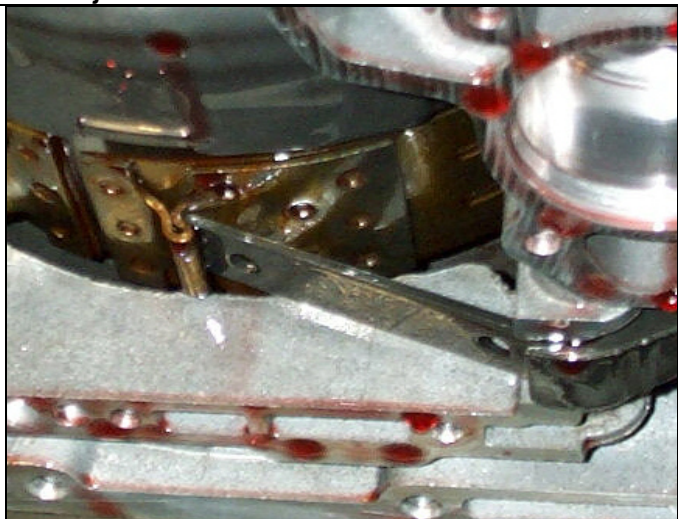

Stock Band Strut in Place



New BD Band Strut In Place

20. Install the new BD strut with tapered side down, towards the pan, and centered in the guides. Torque the band adjustment to 72 lbs.-in, then back it out 1 7/8 turns and then tighten the lock nut. The round end of the enclosed micro-hockey stick tool can also be used as a feeler gauge to set the front band adjustment.

21. From the old valve body, remove the electrical solenoid and sensor, and then install them on the new BD Valve Body.

22. **IMPORTANT** - Before installing the BD valve body, lubricate the manual-shifting shaft and the O-ring on the electrical connector that fit into the transmission case. Rotate the shift lever all the way forward to place the valve body in the 1st / Low gear position for later attaching of the park rod and E-clip.

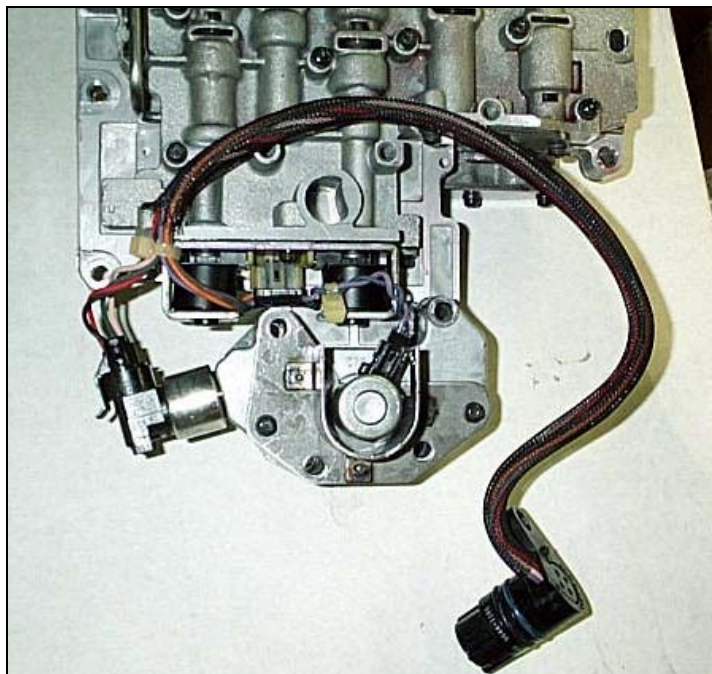

BD Engine Brake, Inc.

Plant Address: Unit A10, 33733 King Rd, Abbotsford, BC, Canada V2S 7M9

U.S. Shipping Address: 88-446 Harrison St, Sumas, WA 98295 U.S. Mailing Address: P.O. Box 231, Sumas, WA 98295

Phone: 604-853-6096 Fax: 604-853-8749 Internet: www.bd-power.com

23. Place the accumulator piston and spring in the BD valve body, if you cannot balance these parts on the valve body, hold them in place with a supporting tool or wire until the valve body is installed.

24. Once the valve body is in position, insert the Park rod into the Manual shift lever and hold the valve body in place with a couple of bolts.



25. Install the E-clip on the park rod using the flat, slotted end of the Canadian micro-hockey stick.

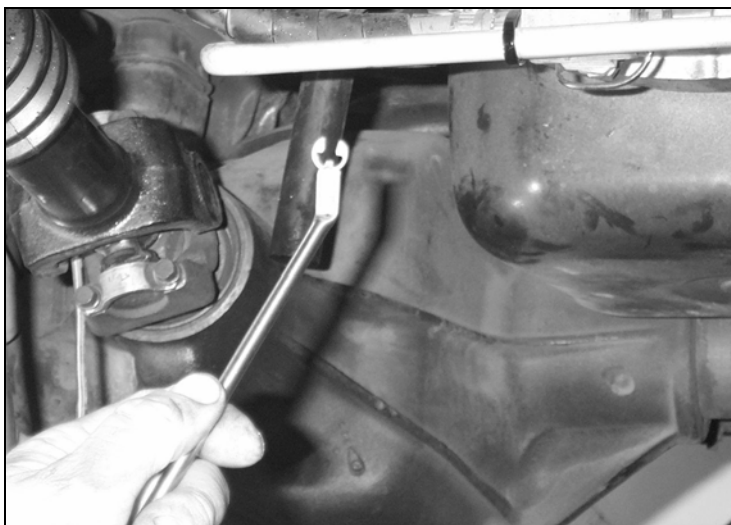

“Hockey Stick” Tool

26. Install the valve body mounting bolts, ensuring the different length bolts are installed in the proper positions, and torque evenly to 10 ft-lbs.
27. Install the manual lever on the outside of the transmission and check for full movement of the detent shift. There must be 5 distinct positions that are felt from Low to Park. Leave in the Neutral position and tighten the retaining bolt.

BD Engine Brake, Inc.

Plant Address: Unit A10, 33733 King Rd, Abbotsford, BC, Canada V2S 7M9

U.S. Shipping Address: 88-446 Harrison St, Sumas, WA 98295 U.S. Mailing Address: P.O. Box 231, Sumas, WA 98295

Phone: 604-853-6096 Fax: 604-853-8749 Internet: www.bd-power.com

28. It is now time to re-install the TTVA motor onto the throttle valve shaft.

- a) Position the transmission throttle valve actuator (TTVA) over the throttle valve shaft (#3).
- b) Align the D-shaped opening in the bottom of the TTVA to the throttle valve shaft and install the TTVA onto the shaft.
- c) Install the wiring connector (#2) to the TTVA (#1).

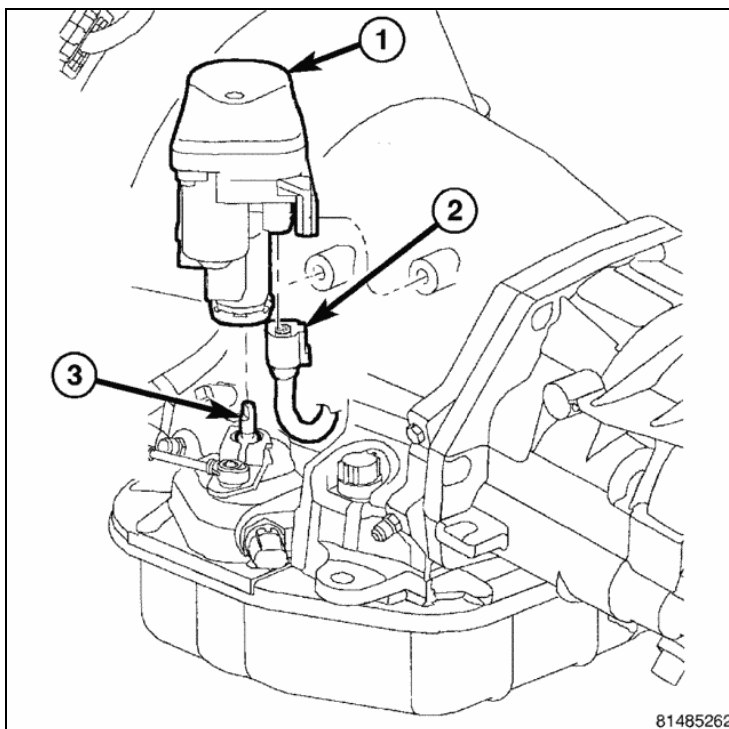

- d) Rotate the TTVA (#1) to the transmission case and install the two bolts to hold the TTVA to the transmission.
- e) Tighten the bolts to **8.5 N·m (75 in.lbs.)**.
- f) Initialize the TTVA.

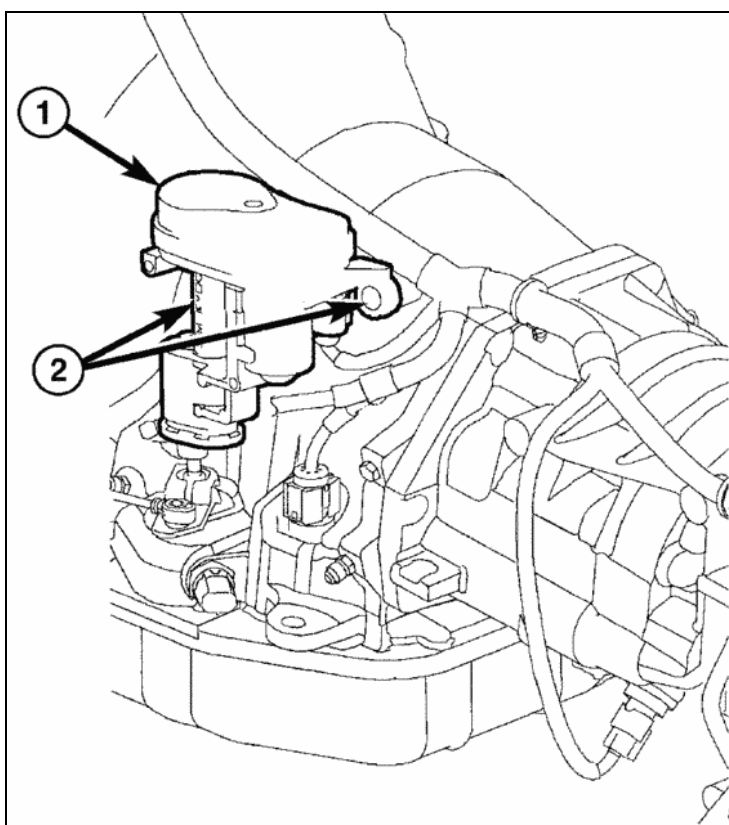

Initialization Procedure:

TURN KEY ON (KOE) THEN OFF THREE TIMES, THEN LEAVE THE KEY IN THE ON POSITION (KOE) FOR 1 FULL MINUTE.

29. Install the neutral safety switch. The reverse lights at the back of vehicle should light when shift lever is in the reverse position (key on).

30. Install the new filter onto the valve body using 3 screws, instead of the 2 that the OEM filter was attached with.

BD Engine Brake, Inc.

Plant Address: Unit A10, 33733 King Rd, Abbotsford, BC, Canada V2S 7M9

U.S. Shipping Address: 88-446 Harrison St, Sumas, WA 98295 U.S. Mailing Address: P.O. Box 231, Sumas, WA 98295

Phone: 604-853-6096 Fax: 604-853-8749 Internet: www.bd-power.com

31. We suggest you install either a drain plug in the original oil pan or, even better, install a BD HD oil pan, which has extra oil capacity, cooling fins, a magnetic drain plug, and adds strength to the transmission case to prevent flexing.
32. Install the shift cable to the manual lever on the transmission. Adjustment of the manual shift cable may be needed at this time. Ensure that the wiring harness has some dielectric grease on it and then connect it. Ensure not to bend the pins when attaching the plug.
33. When just the valve body is replaced, fill the transmission with 8 - 9 quarts of ATF. When both the valve body and torque convertor are replaced, 15 - 17 quarts are required. **IMPORTANT:** After 8 quarts have been added, start engine and shift through all gears, then check the transmission oil level with the shifter in neutral. Top up and check as required. **DO NOT OVERFILL!**
34. After test drive, check oil levels again. Air locks are common in this transmission.
35. Road test vehicle and check for the wide-open shift points to ensure they are correct and to verify pressures.

To recalibrate the TTVA motor you will need to follow the below procedure:

TURN KEY ON (KOE) THEN OFF THREE TIMES, THEN LEAVE THE KEY IN THE ON POSITION (KOE) FOR 1 FULL MINUTE.

NOTE: A RESISTOR IS NOT USED ON 2005-06 48RE VEHICLES

Questions?

If you require assistance with this kit, please call our Transmission Technical Support Line at (800) 887-5030, Monday to Friday from 8:00-4:00pm Pacific Standard Time (PST). As an alternative, you can post a support question on our technical forum, located at <http://www.bd-power.com/forum/>.



BD Engine Brake, Inc.

Plant Address: Unit A10, 33733 King Rd, Abbotsford, BC, Canada V2S 7M9

U.S. Shipping Address: 88-446 Harrison St, Sumas, WA 98295 U.S. Mailing Address: P.O. Box 231, Sumas, WA 98295

Phone: 604-853-6096 Fax: 604-853-8749 Internet: www.bd-power.com

<p style="text-align: center;">BD ENGINE BRAKE, INC. WARRANTY STATEMENT</p>
--

BD Engine Brake, Inc. (BD) warrants to the original purchaser that any products purchased shall be free from defective parts and workmanship. A defect is defined as a condition that would render the product inoperable. BD limits the liability to the repair or replacement, at BD's option, of any warrantable product returned with a complete service history and proof of purchase. A valid proof of purchase is a dated bill of sale. Repaired or replaced products shall be returned to the customer freight collect. Accepted warranty units, which have been replaced, become the sole property of BD.

A Return Material Authorization (RMA) number obtained in advance from a BD customer service representative must accompany product returned, with shipping prepaid by the purchaser, for warranty determination. BD will be the final authority on all warranty decisions.

Labor costs incurred by the removal and replacement of a BD product, while performing warranty work, will be covered for 6 months at authorized service centers. Until the product has been approved at the original installing dealer or at one of our distributors, the consumer shall be responsible for these costs.

NOT COVERED UNDER THIS WARRANTY

This warranty shall not apply to any product that has been improperly stored or installed; or to misapplication, improper operation conditions, accidents, or neglect, or which has been improperly repaired or altered or otherwise mistreated by the owner or his agent. This product warranty shall terminate at the end of 12 months or 24,000 miles of service, which ever comes first, with the original purchaser.

The nature of this product is PERFORMANCE and is designed to perform above OEM specifications. This product was designed with this in mind and should NOT be used in RACING and/or HIGH HORSEPOWER applications and will only be considered for warranty on vehicles with a maximum of 300 REAR WHEEL HORSEPOWER. Using this product on vehicles with a higher rating will cause premature failure and therefore BD will not consider such claims.

Except as set forth in our product outline, BD disclaims any implied warranties of merchantability and fitness for a particular purpose. BD also disclaims any liability for incidental or consequential damages including but not limited to, repair labor, rental vehicles, hotel cost or any other inconvenience costs. This warranty is in lieu of all other warranties or guaranties, either expressed or implied, and shall not extend to any consumer or to any person other than the original purchaser residing within the boundaries of the continental U.S. or Canada.

BD Engine Brake, Inc.

Plant Address: Unit A10, 33733 King Rd, Abbotsford, BC, Canada V2S 7M9

U.S. Shipping Address: 88-446 Harrison St, Sumas, WA 98295 U.S. Mailing Address: P.O. Box 231, Sumas, WA 98295

Phone: 604-853-6096 Fax: 604-853-8749 Internet: www.bd-power.com