



# **1994-2002 DODGE CUMMINS** **2 Low Unloc Differential Kit**

**Part# 1030703**

**OWNER'S MANUAL – LEAVE IN GLOVE BOX**  
Installation Manual Part # I1030703

***Please read entire instruction manual before installation.***

BD ENGINE BRAKE, INC.  
Plant Address: A10-33733 King Rd, Abbotsford, BC, Canada V2S 7M9  
US Shipping Address: 88-446 Harrison St, Sumas, WA 98295 US Mailing Address: PO Box 231, Sumas, WA 98295  
Phone: 604-853-6096 Fax: 604-853-8749 Internet: [www.bd-power.com](http://www.bd-power.com)

# Kit Contents



**Harness w/ 2 Position Switch**

**Spool Valve**

**Black Posi-Tap**



**Vent Hose**

**Phillips Screws (x2)**

**3/16" Barb Splicer (x2)**



**Vacuum Hoses – (2 x 12") , (1 x 18")**

## *Welcome*

Thank you for purchasing the BD 2 Low Unloc Differential Kit. This kit is designed to allow the operator to manually disable the front wheel drive mechanism by holding the hubs in the free (2WD) mode with the transfer case in 4WD low range. By allowing the front wheels to be disengaged, maximum torque is available to the rear wheels. This will also allow for sharp “All The Way Over” turns without the front axle u-joint hopping or binding.

With this kit installed, the front wheels will NOT be driven through the transfer case. This allows the operator to have full power and torque while in a high gear reduction applied to the rear axle(s) only.

**CAUTION: This setup is to be used ONLY in areas where close, tight turns are required without the steering wheel “HOP” normally associated with 4WD operation.**

## *Tools Required*

- Phillips Screwdriver
- Electrical Pliers
- Drill and 15/32” bit (Or Unibit)
- Knife

BD ENGINE BRAKE, INC.

Plant Address: A10-33733 King Rd, Abbotsford, BC, Canada V2S 7M9

US Shipping Address: 88-446 Harrison St, Sumas, WA 98295 US Mailing Address: PO Box 231, Sumas, WA 98295

Phone: 604-853-6096 Fax: 604-853-8749 Internet: [www.bd-power.com](http://www.bd-power.com)

## *Kit Installation*

Mount the 2-Low spool valve bracket onto any free bolt of the Air Inlet Horn.

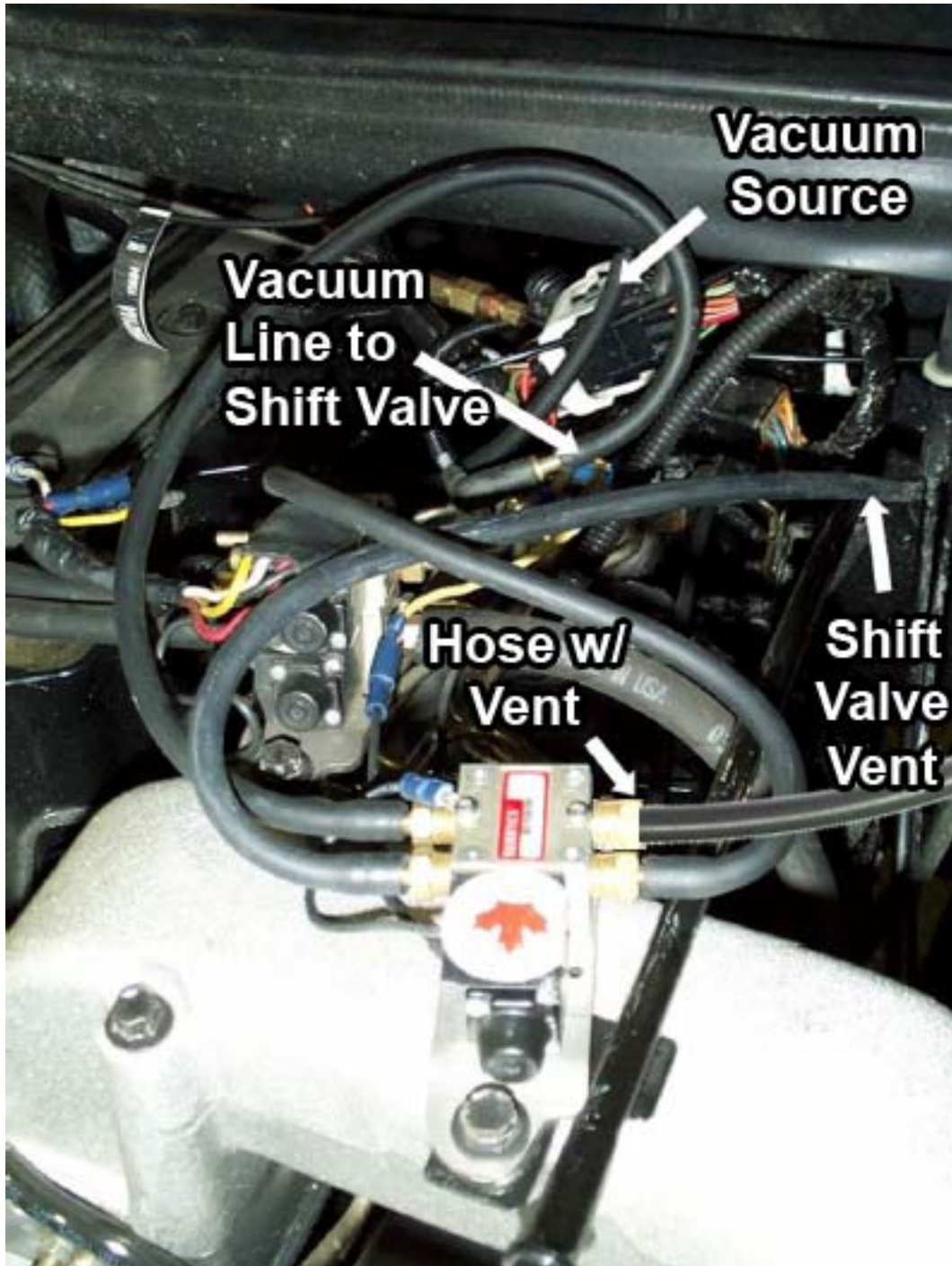

Locate the vacuum source for the front wheel lock actuator where it tees into the main vacuum hose. This is located approximately 10-12" straight behind the intake plenum under the weather stripping of the firewall.

BD ENGINE BRAKE, INC.

Plant Address: A10-33733 King Rd, Abbotsford, BC, Canada V2S 7M9

US Shipping Address: 88-446 Harrison St, Sumas, WA 98295 US Mailing Address: PO Box 231, Sumas, WA 98295

Phone: 604-853-6096 Fax: 604-853-8749 Internet: [www.bd-power.com](http://www.bd-power.com)

**HOSE 1:** Disconnect the vacuum hose from the source T-fitting located at the center of the firewall. Using one of the short hoses supplied, connect one end onto the male end of the source T-fitting at the firewall and then the other end onto the barb fitting of the control valve marked with a "1".

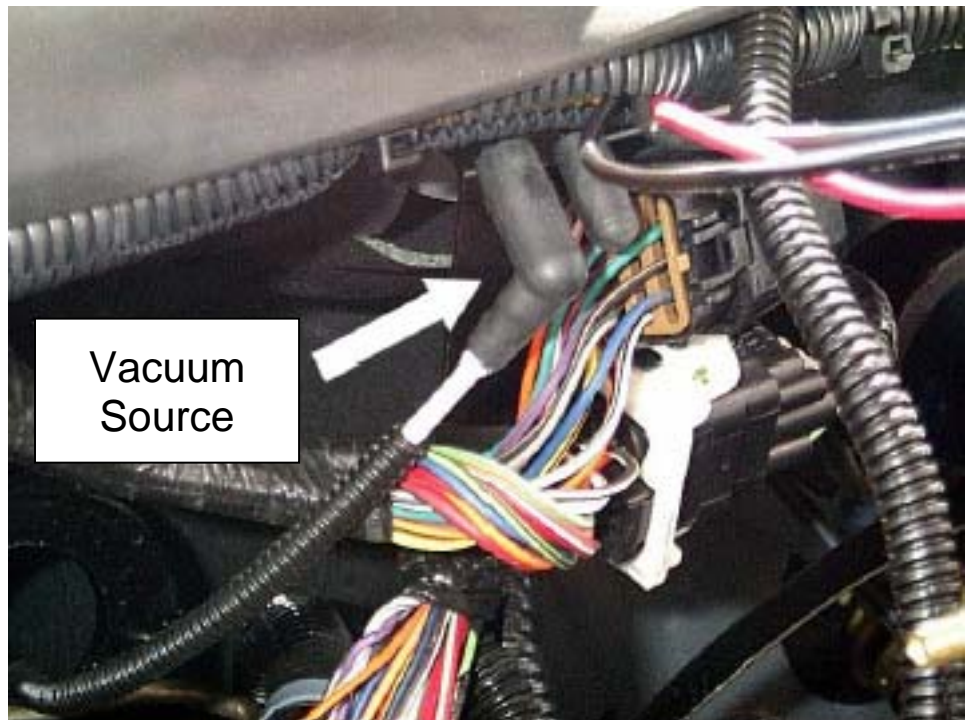

**HOSE 2:** Using the other short hose supplied, install one end of the barb fitting of the control valve identified with a "2". Install one of the supplied straight splicer barbs into the other end of this hose and attach it to the vacuum source line removed from the firewall fitting.

**HOSE 3:** From just behind the rear engine lift eye, locate and remove the vacuum hose vent valve from the vent line of the transfer case hub control switch and install one of the straight barb fittings. Using the longer piece of hose supplied, install one end onto the fitting of the control valve marked with a "4". Install the other end onto the barb fitting that was installed in the vent hose.

**HOSE 4:** Install the length of hose that has the brass filter fitted in one end onto the control valve fitting marked with a "3" and secure the filter end up under the hood weather stripping or run into the cab (sheltered from elements to prevent water and dirt from entering the valve).

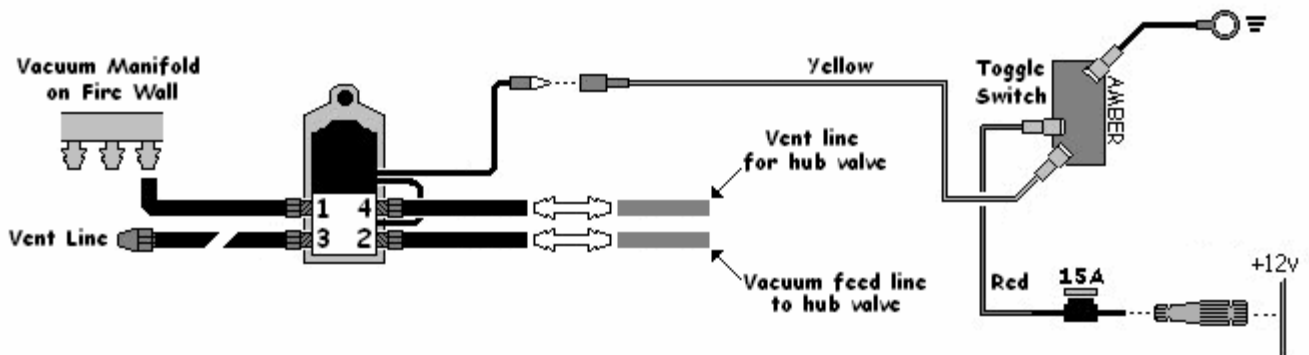

Locate a suitable spot of your choice in the cab for the toggle switch and drill a hole. Insert the switch and secure with the plastic nut.



Run the purple (or yellow) wire through the firewall and plug into the connector on the spool valve. Fasten the black wire to a good ground under the dash.

Install the Posi-Tap connector onto a switched 12-volt power source.

Ensure the 15amp fuse is installed and plugged into the connector.

## Operation

To test the function of the 2 Low Kit, start the vehicle and shift the transfer case into the 4-Low range and start moving. The "4WD" dash indicator should come on. Steering all the way over, operate the truck and you should feel the steering hop as the front axle driveline is engaged and has torque applied to it (this is normal).

Stop the truck and with the front wheels relatively straight, turn the 2-Low switch to the ON position. The light on the switch should now be on, indicating operation. Wait approximately 3 seconds for the vacuum to build up and then start to move - the "4WD" indicator on the dash should come off indicating 2WD operation. If you now move with the steering all the way over you should have no steering hop as the front drive axles are prevented from engaging.

**\*\*NOTE\*\*:** This setup redirects the front axle vacuum source and vent lines. If the switch is left in the ON position when the transfer case is in 2WD, the front axle lock will stay engaged but no drive will be transferred from the transfer case as the lever is in 2WD position which could cause undue wear on the front axles.

BD ENGINE BRAKE, INC.

Plant Address: A10-33733 King Rd, Abbotsford, BC, Canada V2S 7M9

US Shipping Address: 88-446 Harrison St, Sumas, WA 98295 US Mailing Address: PO Box 231, Sumas, WA 98295

Phone: 604-853-6096 Fax: 604-853-8749 Internet: [www.bd-power.com](http://www.bd-power.com)

## **BD Engine Brake, Inc.** *Limited Warranty Statement*

THE INSTALLATION OF THIS PRODUCT INDICATES THAT THE BUYER HAS READ AND UNDERSTANDS THIS AGREEMENT AND ACCEPTS ITS TERMS AND CONDITIONS.

### **DISCLAIMER OF LIABILITY**

BD Engine Brake Inc., its successors, distributors, jobbers, and dealers (hereafter "**BD**") shall in no way be responsible for the product's proper use and service. THE BUYER HEREBY WAIVES ALL LIABILITY CLAIMS.

**BD** disclaims any warranty and expressly disclaims any liability for personal injury or damages. **BD** also disclaims any liability for incidental or consequential damages including, but not limited to, repair labor, rental vehicles, hotel costs, or any other inconvenience costs by reason of use or sale of any such equipment. The **BUYER** acknowledges and agrees that the disclaimer of any liability for personal injury is a material term for this agreement and the **BUYER** agrees to indemnify **BD** and to hold **BD** harmless from any claim related to the item of any equipment purchased.

This warranty shall not apply to any unit that has been improperly stored or installed, or to misapplication, improper operation conditions, accidents, neglect, or which has been improperly repaired or altered or otherwise mistreated by the **BUYER** or his agent. **BD** also assumes no liability regarding the improper installation or misapplication of its products. It is the installer's responsibility to check for proper installation and if in doubt, contact the manufacturer.

### **LIMITATION OF WARRANTY**

BD Engine Brake Inc. (hereafter "**BD**") warrants to the **BUYER** that any parts purchased shall be free from defects in material workmanship. A defect is defined as a condition within the product that would render the product inoperable. **BD** gives Limited Warranty as to description, quality, merchantability, fitness for any product's purpose, productiveness, or any other matter of **BD's** product sold herewith. **BD** shall be in no way responsible for the product's open use and service and the **BUYER** hereby waives all rights other than those expressly written herein. This Warranty shall not be extended or varied except by a written instrument signed by **BD** and the **BUYER**.

**The Warranty is Limited to two (2) years from the date of sale. Labor costs incurred by the removal and replacement of the BD product, while performing warranty work, will be covered for 1 (one) year, payable at BD rates, at authorized centers and with prior approval. Until BD has approved the claim, the consumer may be responsible for these costs.**

A Return Authorization (WA) number, obtained in advance from **BD**, must accompany all products returned for warranty consideration. All products must be returned, shipping prepaid, to **BD** and must be accompanied by a dated proof of purchase receipt. All Warranty claims are subject to approval by **BD** and repaired or replaced product will be returned to the customer freight collect. Accepted warranty units, which have been replaced, become the sole property of **BD**.

This warranty is in lieu of all other warranties or guaranties, either expressed or implied, and shall not extend to any consumer or to any person other than the original purchaser residing within the boundaries of the continental U.S. or Canada.

IN THE EVENT THAT THE BUYER DOES NOT AGREE WITH THIS AGREEMENT, THE BUYER MAY PROMPTLY RETURN THIS PRODUCT, IN A NEW AND UNUSED CONDITION, WITH A DATED PROOF OF PURCHASE, TO THE PLACE OF PURCHASE WITHIN THIRTY (30) DAYS FROM DATE OF PURCHASE FOR A FULL REFUND.

BD ENGINE BRAKE, INC.

Plant Address: A10-33733 King Rd, Abbotsford, BC, Canada V2S 7M9

US Shipping Address: 88-446 Harrison St, Sumas, WA 98295 US Mailing Address: PO Box 231, Sumas, WA 98295

Phone: 604-853-6096 Fax: 604-853-8749 Internet: www.bd-power.com