



2011-2012 Ford 6.7L Powerstroke **Positive Air Shutoff**







P/N#	1036703
P/N#	1036703-M

PLEASE READ ALL INSTRUCTIONS BEFORE INSTALLATION

KIT CONTENTS:

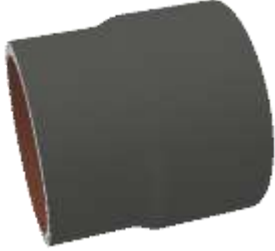
Please check to make sure that you have all the parts listed in this kit **before** you start the disassembly of your truck.

1036703 Kit Contents			
1302300	1302258	1302274	
			
<i>Air Shutoff Valve</i>	<i>Wiring Harness</i>	<i>3"-3 1/4" Silicone Boot</i>	
Qty: 1	Qty: 1	Qty: 2	
1302280	1302282	1407030	1405211
			
<i>3" PAS Bead Ring</i>	<i>PAS Drill Template</i>	<i>0350 Clamps</i>	<i>0325 Clamps</i>
Qty: 2	Qty: 2	Qty: 2	Qty: 2
1800060	1301381	1306710	1302285
			
<i>Velcro strips</i>	<i>Heat Shrink</i>	<i>Ford Electronic Module</i>	<i>Solder</i>
Qty: 2 x 4"	Qty: 3"	Qty: 1	Qty: 5"

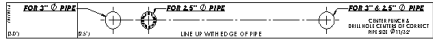
1036703-M Kit Contents			
1302300	1302249	1302274	
			
<i>Air Shutoff Valve</i>	<i>Wiring Harness</i>	<i>3\"-3 1/4\" Silicone Boot</i>	
Qty: 1	Qty: 1	Qty: 2	
1302280	1405211	1407030	1302282
			
<i>3\" PAS Bead Ring</i>	<i>0325 Clamps</i>	<i>0350 Clamps</i>	<i>PAS Drill Template</i>
Qty: 2	Qty: 2	Qty: 2	Qty: 2

WELCOME

Thank you for purchasing a BD positive air shutoff. This manual is divided into different areas to assist you with your installation and operation of your positive Air shutoff.

This product is a safety product and should be tested often.

Installation should occur on a vehicle properly secured to prevent rolling.

TABLE OF CONTENTS

1036703 Kit Contents	2
1036703-M Kit Contents	3
REQUIRED TOOLS.....	4
MAINTENANCE.....	5
INSTALLATION with OVER SPEED ELECTRONICS (1036703).....	5
INSTALLATION without OVER SPEED ELECTRONICS (1036703-M).....	18
BEAD RING AND DRILL JIG INSTALLATION.....	29
WIRING DIAGRAM with OVER SPEED ELECTRONICS (1036703)	30
WIRING DIAGRAM without OVER SPEED ELECTRONICS (1036703-M)	31
RESETTING THE VALVE.....	32
SETUP, TESTING AND VERIFICATION with OVER SPEED ELECTRONICS.....	33
Automatic Mode (Pre Configured RPM)	33
Manual Mode (User Configured RPM)	35
TESTING FLOW CHART with OVER SPEED ELECTRONICS	38
TESTING FLOW CHART without OVER SPEED ELECTRONICS	39
LED OPERATION.....	40

REQUIRED TOOLS

- Frequency/Voltmeter (Optional)
- Drill
- 11/32" Drill Bit
- 1/8" Drill Bit
- 1/2" Unibit
- Electrical Tape
- Heat Gun
- Needle Nose Pliers
- Reciprocating saw
- Soldering Iron
- Air or Manual Ratchet
- 7/16", 1/2" Sockets
- Wire Strippers
- Wire Cutters
- Flat Screw Driver
- Center Punch
- Band Saw/ Cut Off Wheel
- Center Punch

BD Engine Brake Inc.

Plant Address: 33541 MacLure Rd. Abbotsford, BC, Canada V2S 7W2

U.S. Shipping Address: 88-446 Harrison St, Sumas, WA 98295 U.S. Mailing Address: P.O. Box 231, Sumas, WA 98295

Phone: 604-853-6096 | Fax: 604-853-8749 | Internet: www.bd-power.com

MAINTENANCE

No maintenance is needed other than check to make sure the valve is acting correctly. Please see the testing section later in the manual for the correct procedure.

INSTALLATION with OVER SPEED ELECTRONICS (1036703)

VEHICLE SHOULD BE SAFELY SECURED BEFORE INSTALLATION.

1. Block the wheels of the vehicle to prevent the vehicle from rolling.

Open the hood.

2. Remove the charge air cooler pipe using a flat screwdriver to release the spring clips on both sides of the turbo intake, and a 7/16" socket and ratchet to loosen both T clamps to release the pipe from the water to air cooler.

NOTE: Keep all spring clamps as you will be reusing them.



BD Engine Brake Inc.

Plant Address: 33541 MacLure Rd. Abbotsford, BC, Canada V2S 7W2

U.S. Shipping Address: 88-446 Harrison St, Sumas, WA 98295 U.S. Mailing Address: P.O. Box 231, Sumas, WA 98295

Phone: 604-853-6096 | Fax: 604-853-8749 | Internet: www.bd-power.com

3. Once the pipe is removed from the truck, you can make your first cut at 4 1/2" from the factory pipe benders grip start on the C.A.C. side.

***IMPORTANT* Ensure all cuts are straight.**



4. Then make the second cut from the grip start at 1 1/4".



BD ENGINE BRAKE, INC.

Plant Address: A10-33733 King Rd, Abbotsford, BC, Canada V2S 7M9

US Shipping Address: 88-446 Harrison St, Sumas, WA 98295 US Mailing Address: PO Box 231, Sumas, WA 98295

Phone: 604-853-6096 Fax: 604-853-8749 Internet: www.bd-power.com

When both pipes are cut they should look like this.



WATER TO AIR PIPE



TURBO PIPE

5. Remove backing from drill Jig sticker and wrap around pipe. The edge of the sticker should line up with the edge of the pipe.

For the 3" pipe the sticker should wrap perfectly around the pipe, the start of the sticker should meet the end of the sticker.

NOTE: Refer to the Bead Ring and Drill Jig Installation section on page 29 in this manual if you require more information.

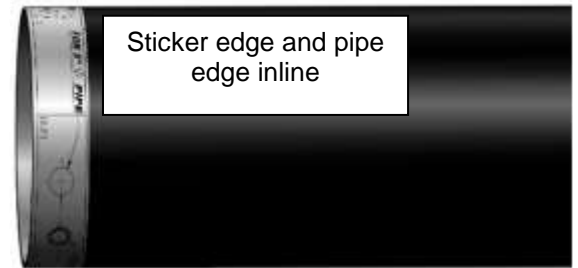
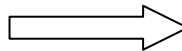
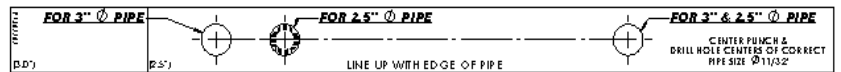

6. With the sticker in place use a center punch and then use a $\text{Ø}1/8$ " drill bit and drill a hole in the center of the holes marked "For 3Ø".

There will be two holes and they should be perfectly 180° inline with each other through the pipe.

DO NOT DRILL COMPLETELY THROUGH THE PIPE AND OUT THE OTHER END. YOU WILL NEED TO DRILL ONE SIDE THEN ROTATE, AND THEN DRILL THE OTHER SIDE.

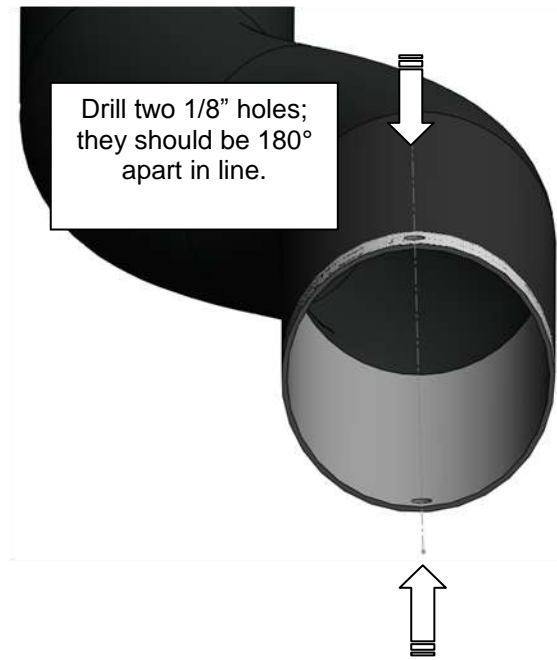

7. Once the pilot holes are drilled you will need to drill an $\text{Ø}11/32$ " hole through the pilot holes.

You can now remove the sticker.

You must deburr the inside of the drilled holes.

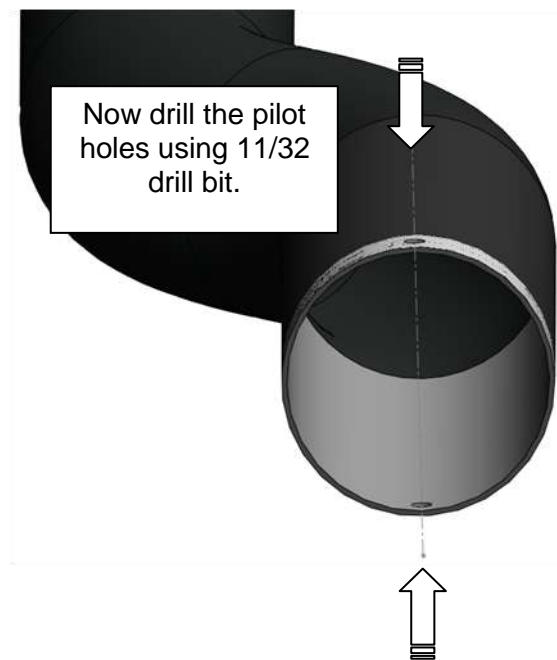

BD ENGINE BRAKE, INC.

Plant Address: A10-33733 King Rd, Abbotsford, BC, Canada V2S 7M9

US Shipping Address: 88-446 Harrison St, Sumas, WA 98295 US Mailing Address: PO Box 231, Sumas, WA 98295

Phone: 604-853-6096 Fax: 604-853-8749 Internet: www.bd-power.com

8. Once the holes are drilled, install the ring bead around the pipe. Lock each end of the ring bead into each hole.

You can use needle nose pliers to tweak or adjust the ring fit slightly.

Be careful not to bend the ring bead to much as you will weaken it.

Note the ring bead does not have to be perfectly tight or snug around the pipe, as we will be installing a silicone boot over top of it.

With the ring bead in place, you should not be able to pull the ring bead off axially from the tube.

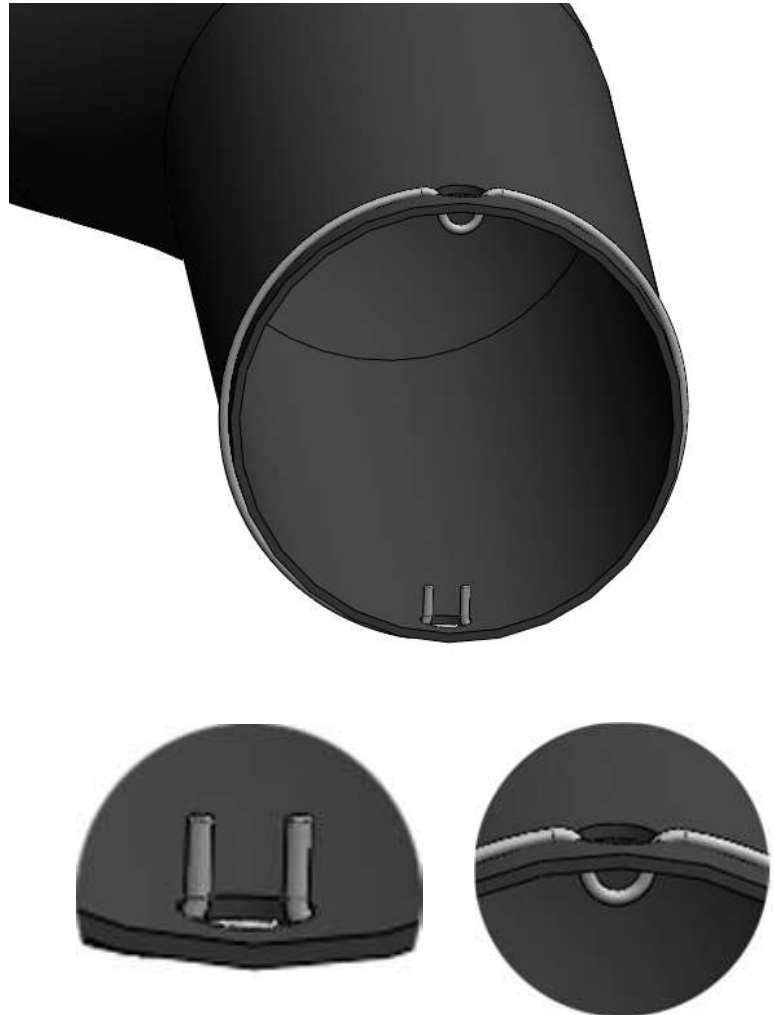

BD ENGINE BRAKE, INC.

Plant Address: A10-33733 King Rd, Abbotsford, BC, Canada V2S 7M9

US Shipping Address: 88-446 Harrison St, Sumas, WA 98295 US Mailing Address: PO Box 231, Sumas, WA 98295

Phone: 604-853-6096 Fax: 604-853-8749 Internet: www.bd-power.com

9. Once the bead rings are on the pipes install the boots (1302274) onto the valve using the supplied spring clamps 0350 (1407030), then connect the pipes to the valve assembly ensuring the arrow on the valve points away from the pipe that connects to the turbo.

Secure the boot with the provided 0325 clamps (1405211). Note that there should be about 3/4"-1" of silicone material after the bead ring.

Note: leave clamps loose to allow for movement.

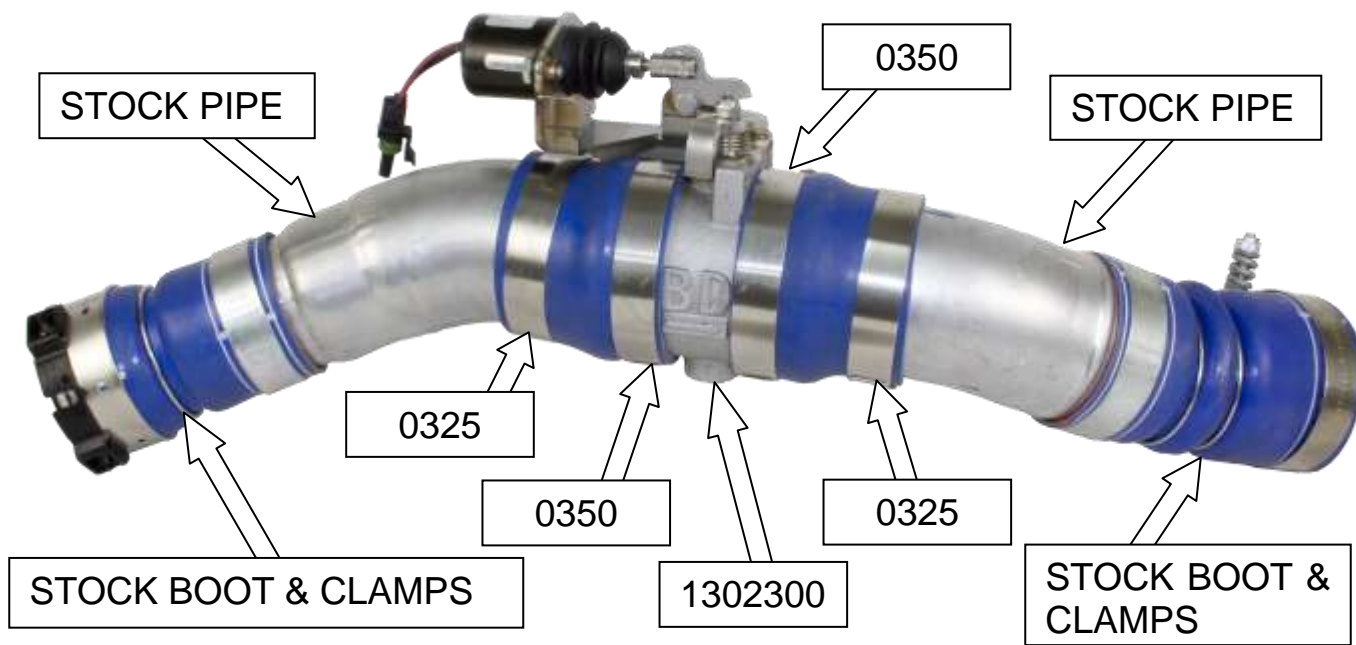

10. Install the assembly into the truck, clock pipe sections and valve for clearance.

Tighten all clamps until spring is bound.



11. Lay out supplied harness over top of the driver's side of the engine.

You will then need to route the switch wires through the firewall on the driver's side (note you will need to remove the switch from the harness to accomplish this). See wiring diagram on page 30

Choose a highly visible location for the switch and mount it to the dash.

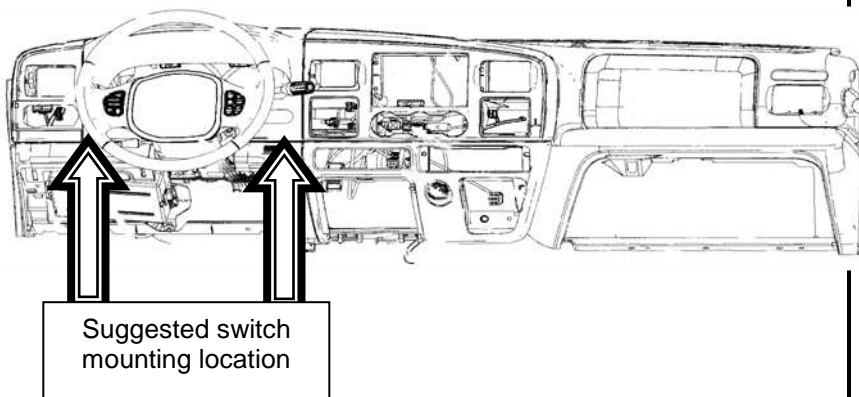

12. Using a 1/8" drill, drill a pilot hole in the location you have selected for the switch to be mounted.

Finally using a 1/2" UNIBIT drill bit, drill an exact 1/2" round hole.

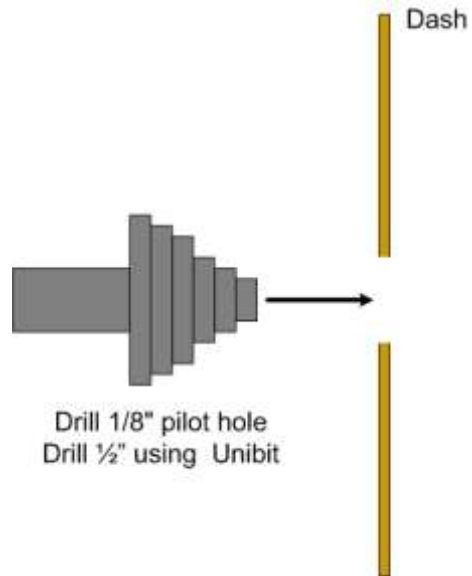

13. Once you have the mounting hole drilled, insert the switch from the backside.

Reinstall the correct wires to the correct switch terminals.

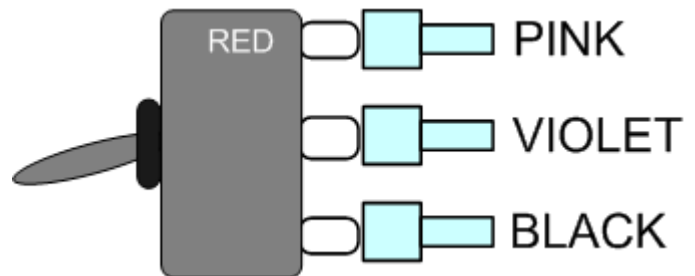

14. Mount the switch so that the groove on thread boss is facing down.

Adjust the HEX washer/nut so that the switch threads do not protrude an unsightly amount.

Then apply the supplied sticker and finally install the round plastic nut.

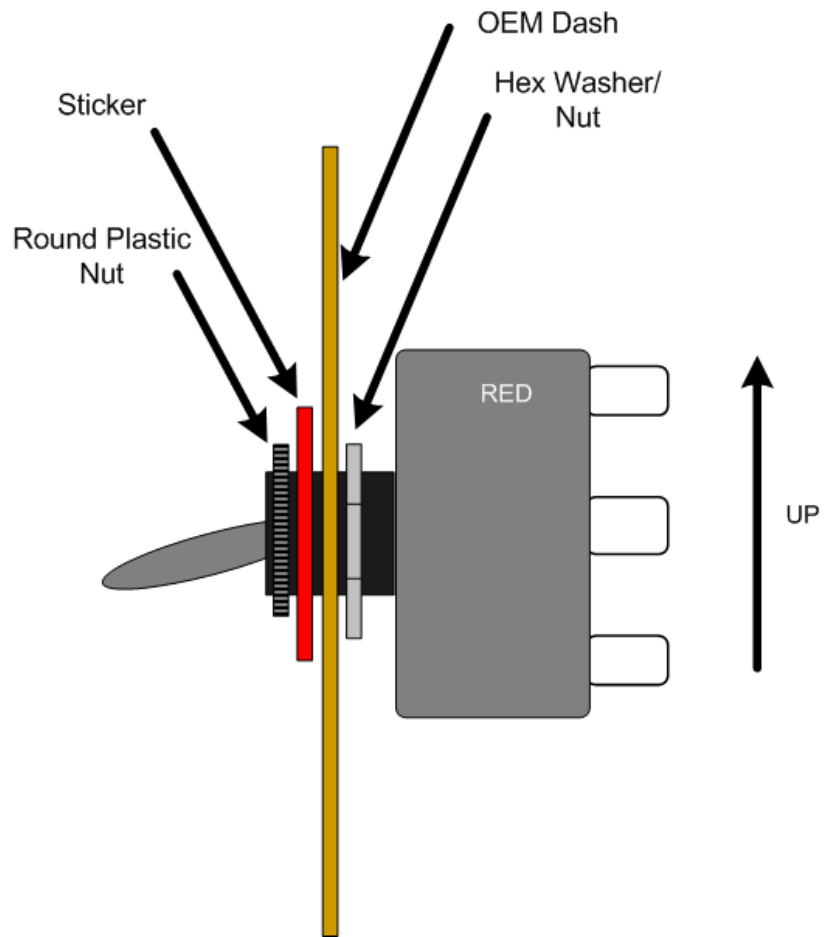

15. Now underneath the hood locate and connect the weather pack connector on the wiring harness to the solenoid on the PAS valve. See page 30 for more info.

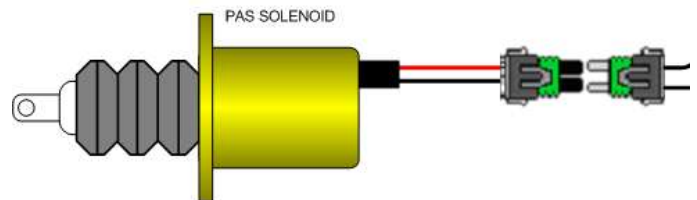

16. You will now need to locate the crankshaft position sensor wire (pin 33) at the PCM connector on the passenger side of the firewall.

Year	PCM Pin	Wire Color
2011	33	Yellow/Orange
2012	33	Yellow/Orange



17. Being that the RPM signal is critical you will need to solder the connection.

Using wire strippers create a 1" window/gap in insulation of the wire.

Then strip about 1" of insulation of the RPM signal wire of the BLUE wire from the PAS wiring harness.

Wrap the copper wire around the factory RPM signal wire and solder this connection.

Then use electrical tape to wrap this connection so that it is water tight.

You can also cut the factory crank signal wire and use heat shrink tubing if you would like.

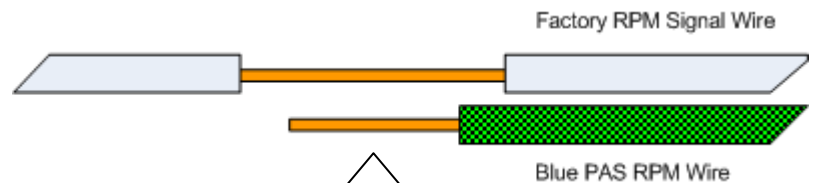

Solder the connection and then wrap and seal with electrical tape

18. Next on the wiring harness, connect the BLACK and RED wires to the respective battery connections. (Driver's Side Battery).



BD ENGINE BRAKE, INC.

Plant Address: A10-33733 King Rd, Abbotsford, BC, Canada V2S 7M9

US Shipping Address: 88-446 Harrison St, Sumas, WA 98295 US Mailing Address: PO Box 231, Sumas, WA 98295

Phone: 604-853-6096 Fax: 604-853-8749 Internet: www.bd-power.com

19. For the last connection you will need to locate ignition power. This will power the automatic over speed control box LED switch. Note that the unit can still be activated manually with the switch at any time.

Locate the fuse box under the hood (driver's side in front of firewall). Remove junction box cover and locate the appropriate fused ignition power circuit (See table below). Install fuse tapper onto fuse #49 and reinstall fuse. Connect the yellow lead wire with flag connector to this new connection. Route wire out of the fuse box and close lid.

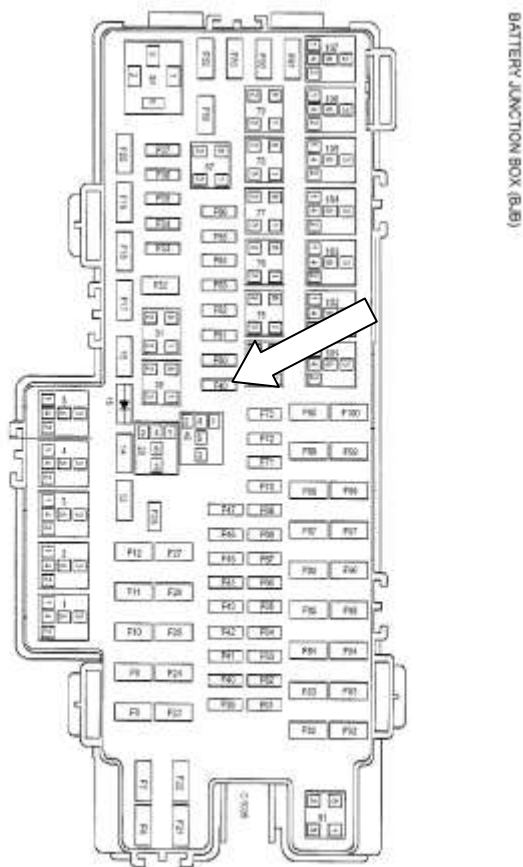

Fuse #49 (10 AMP)

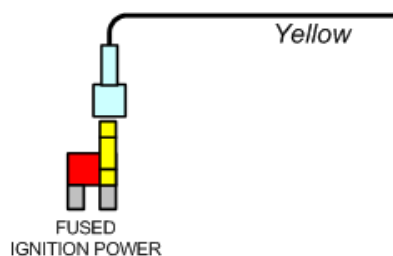

20. Mount the electronic control unit on to the junction box.

Be sure to clean the mounting surface with alcohol before applying the supplied Velcro.

Connect the wiring harness to the electronic control unit.

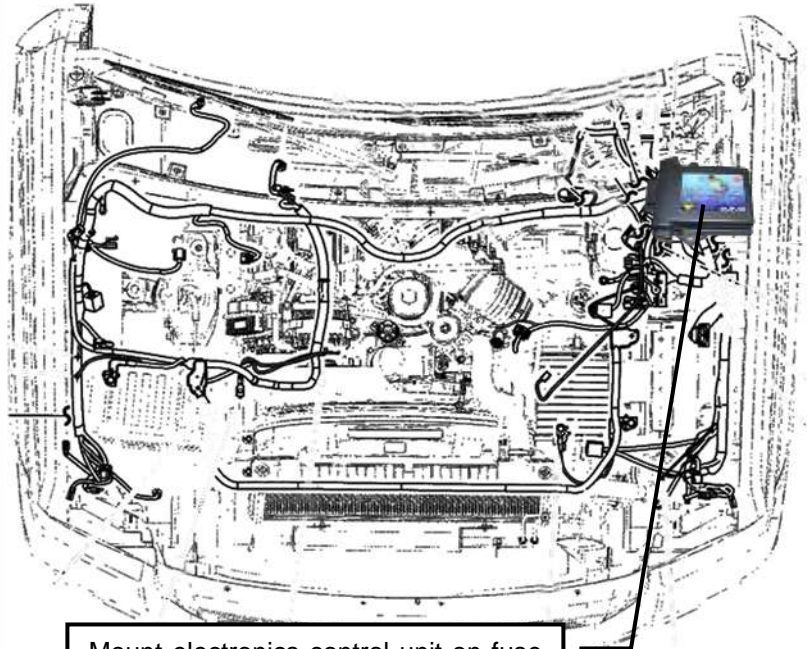

Mount electronics control unit on fuse box using Velcro.

Double check all wiring connections and ensure wires are routed away from any heat sources and moving parts, and continue to the Setup, Testing and Verification section in this manual.

BD ENGINE BRAKE, INC.

Plant Address: A10-33733 King Rd, Abbotsford, BC, Canada V2S 7M9

US Shipping Address: 88-446 Harrison St, Sumas, WA 98295 US Mailing Address: PO Box 231, Sumas, WA 98295

Phone: 604-853-6096 Fax: 604-853-8749 Internet: www.bd-power.com

INSTALLATION without OVER SPEED ELECTRONICS (1036703-M)**VEHICLE SHOULD BE SAFELY SECURED BEFORE INSTALLATION.**

1. Block the wheels of the vehicle to prevent the vehicle from rolling.

Open the hood.

2. Remove the charge air cooler pipe using a flat screwdriver to release the spring clips on both sides of the turbo intake, and a 7/16" socket and ratchet to loosen both T clamps and release the pipe from the water to air cooler.

NOTE: Keep all spring clamps as you will be reusing them.



3. Once the pipe is removed from the truck, you can make your first cut at 4 1/2" from the factory pipe benders grip start on the C.A.C. side.

IMPORTANT Ensure all cuts are straight.



4. Then make the second cut from the grip start at 1 1/4".



INSTALLATION without OVER SPEED ELECTRONICS

When both pipes are cut they should look like this.



WATER TO AIR PIPE



TURBO PIPE

5. Remove backing from drill Jig sticker and wrap around pipe. The edge of the sticker should line up with the edge of the pipe.

For the 3" pipe the sticker should wrap perfectly around the pipe, the start of the sticker should meet the end of the sticker.

NOTE: Refer to the Bead Ring and Drill Jig Installation section on page 29 in this manual if you require more information.

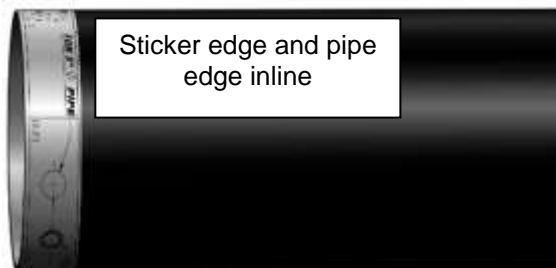
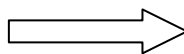
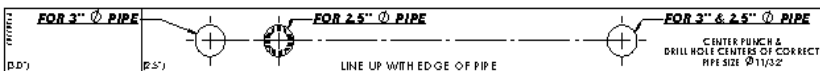

INSTALLATION without OVER SPEED ELECTRONICS

BD ENGINE BRAKE, INC.

Plant Address: A10-33733 King Rd, Abbotsford, BC, Canada V2S 7M9

US Shipping Address: 88-446 Harrison St, Sumas, WA 98295 US Mailing Address: PO Box 231, Sumas, WA 98295

Phone: 604-853-6096 Fax: 604-853-8749 Internet: www.bd-power.com

6. With the sticker in place use a center punch and then use a $\text{\O}1/8$ " drill bit and drill a hole in the center of the holes marked "For 3 \O ".

There will be two holes and they should be perfectly 180° inline with each other through the pipe.

DO NOT DRILL COMPLETELY THROUGH THE PIPE AND OUT THE OTHER END. YOU WILL NEED TO DRILL ONE SIDE THEN ROTATE, AND THEN DRILL THE OTHER SIDE.

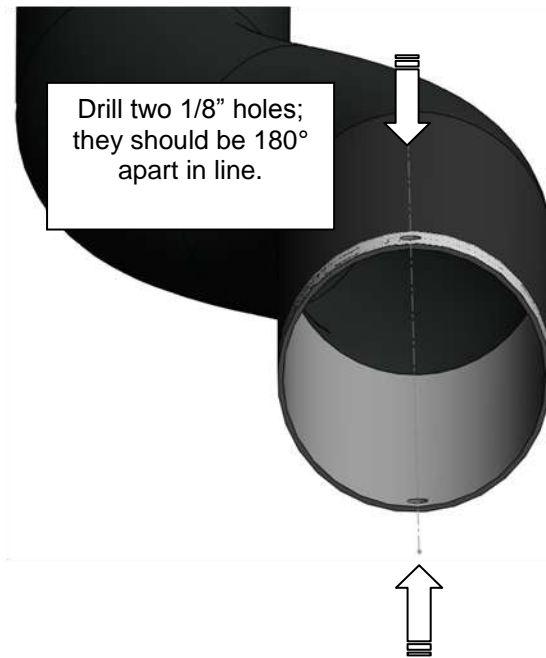

7. Once the pilot holes are drilled you will need to drill an $\text{\O}11/32$ " hole through the pilot holes.

You can now remove the sticker.

You must deburr the inside of the drilled holes.

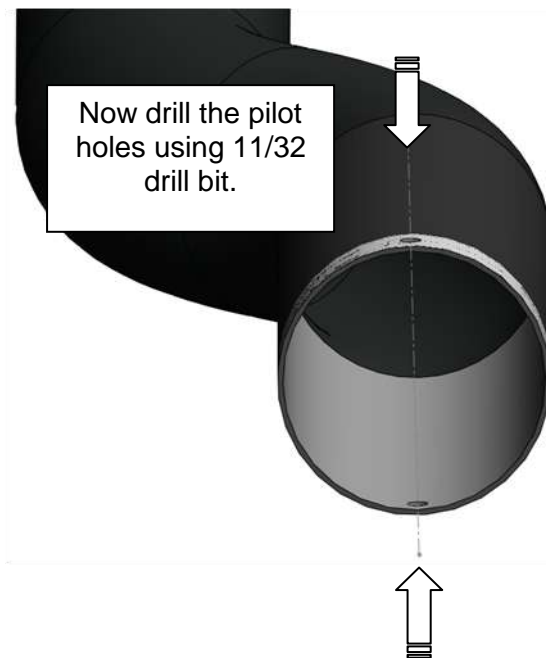

8. Once the holes are drilled, install the ring bead around the pipe. Lock each end of the ring bead into each hole.

You can use needle nose pliers to tweak or adjust the ring fit slightly.

Be careful not to bend the ring bead to much as you will weaken it.

Note the ring bead does not have to be perfectly tight or snug around the pipe, as we will be installing a silicone boot over top of it.

With the ring bead in place, you should not be able to pull the ring bead off axially from the tube.



9. Once the bead rings are installed, connect the pipes to the valve assembly ensuring the arrow on the valve points towards the pipe that connects to the turbo.

Secure the boot with the provided 3.5" clamp (1407030). Note that there should be about 3/4"-1" of silicone material after the bead ring.

Note: leave clamps loose to allow for movement.

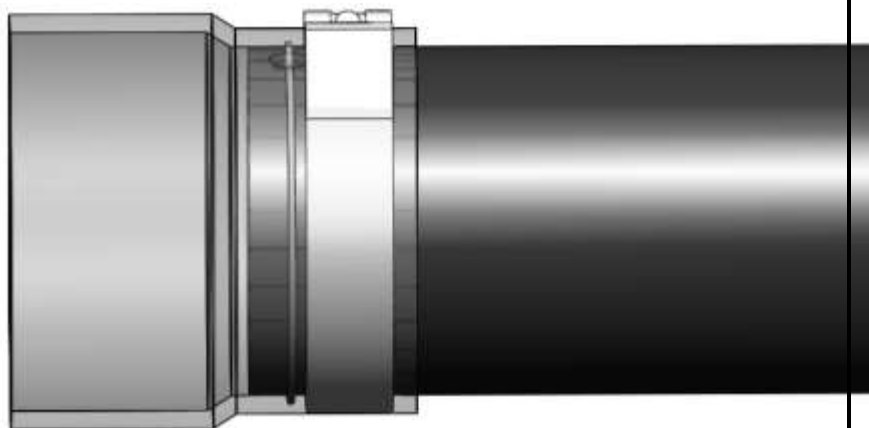

BD ENGINE BRAKE, INC.

Plant Address: A10-33733 King Rd, Abbotsford, BC, Canada V2S 7M9

US Shipping Address: 88-446 Harrison St, Sumas, WA 98295 US Mailing Address: PO Box 231, Sumas, WA 98295

Phone: 604-853-6096 Fax: 604-853-8749 Internet: www.bd-power.com

10. Once the bead rings are on the pipes install the boots (1302274) onto the valve using the supplied spring clamps 0350 (1407030), then connect the pipes to the valve assembly ensuring the arrow on the valve points away from the pipe that connects to the turbo.

Secure the boot with the provided 0325 clamps (1405211). Note that there should be about 3/4"-1" of silicone material after the bead ring.

Note: leave clamps loose to allow for movement.

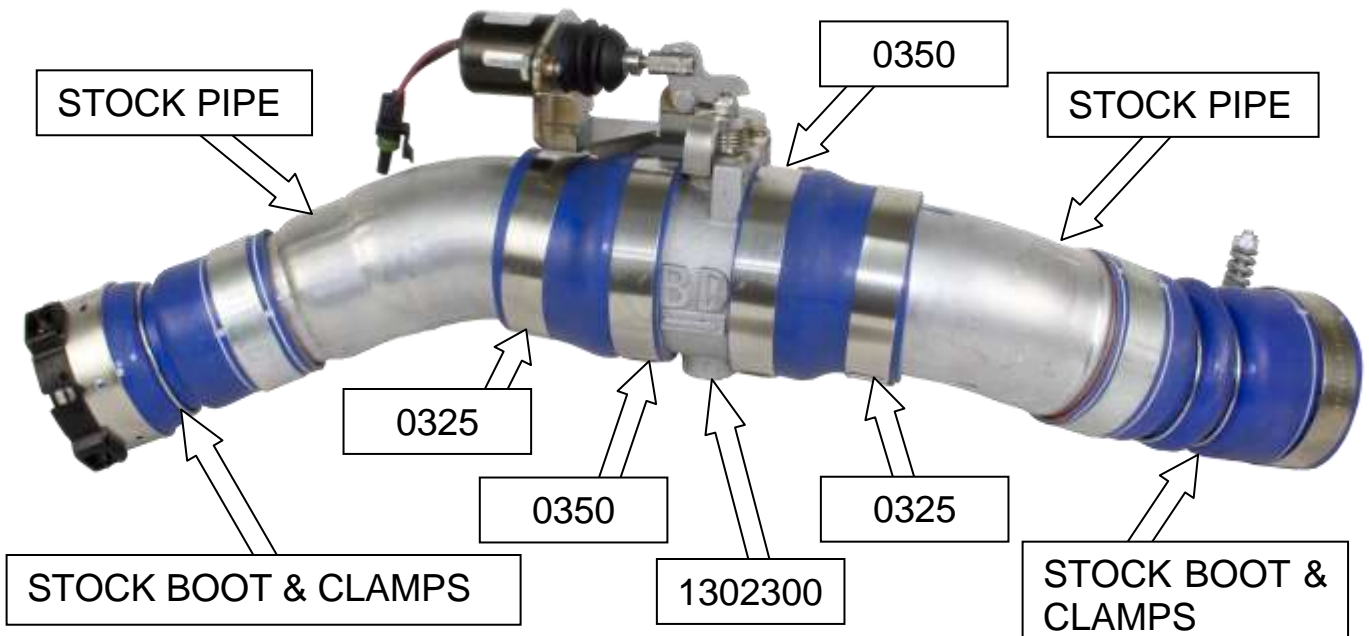
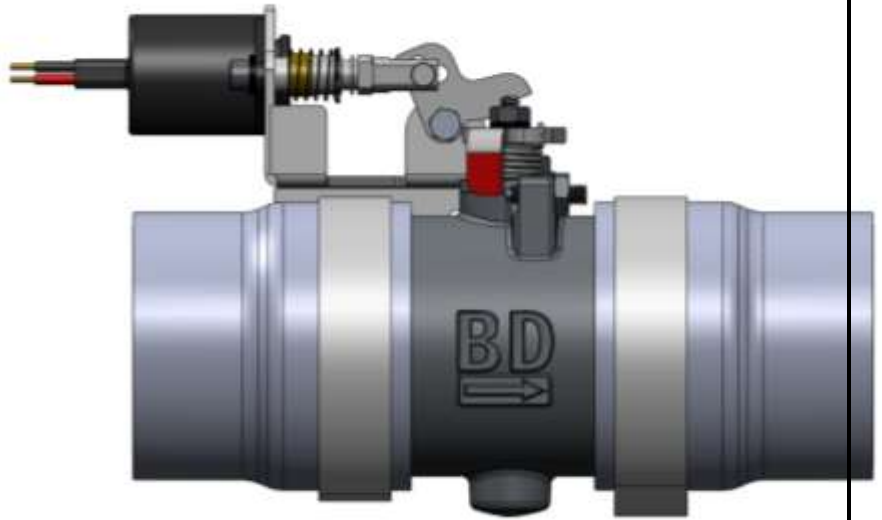

INSTALLATION without OVER SPEED ELECTRONICS

11. Install assembly into the truck, clock pipe sections and valve for clearance.

Tighten all clamps until spring is bound.



12. Lay out supplied harness over top of the driver's side of the engine.

You will then need to route the switch wires through the firewall on the driver's side (note you will need to remove the switch from the harness to accomplish this). See wiring diagram on page 31

Choose a highly visible location for the switch and mount it to the dash.

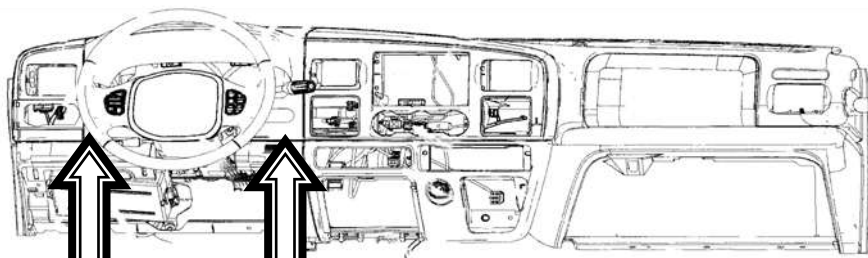

Suggested switch mounting location

Using a 1/8" drill, drill a pilot hole in the location you have selected for the switch to be mounted.

Finally using a 1/2" UNIBIT drill bit, drill an exact 1/2" round hole.

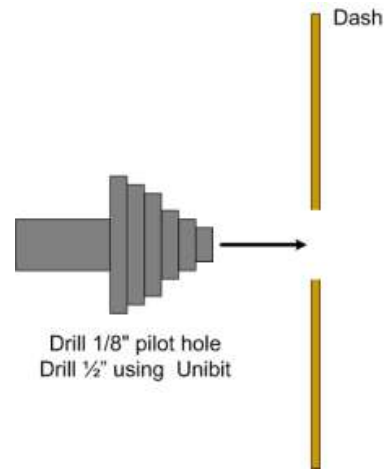

13. Once you have the mounting hole drilled, insert the switch from the backside.

Reinstall the correct wires to the correct switch terminals.

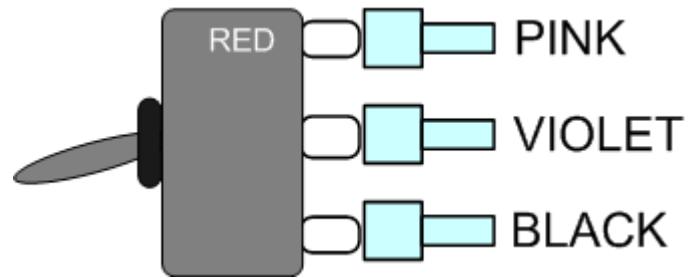

14. Mount the switch so that the groove on thread boss is facing down.

Adjust the HEX washer/nut so that the switch threads do not protrude an unsightly amount.

Then apply the supplied sticker and finally install the round plastic nut.

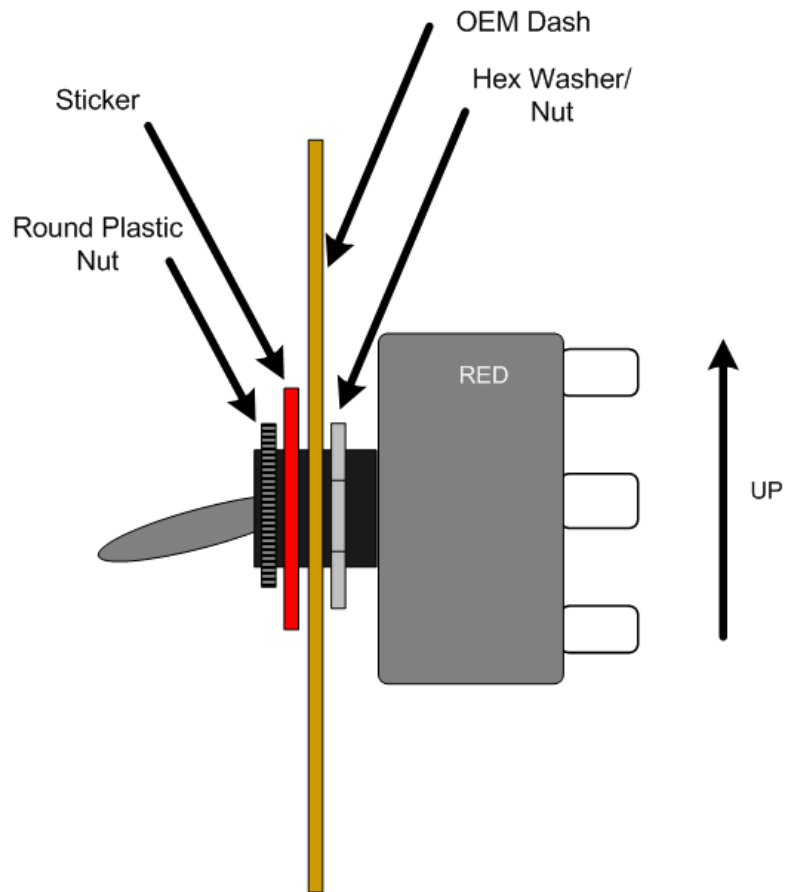

15. Now underneath the hood locate and connect the weather pack connector on the wiring harness to the solenoid on the PAS valve. See page 31 for more info.

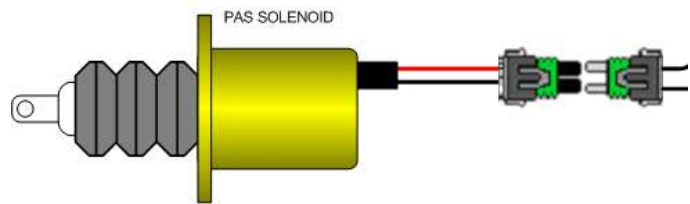

16. Next on the wiring harness, connect the BLACK and RED wires to the respective battery connections (Driver's Side Battery).



17. For the last connection you will need to locate ignition power.

Locate the fuse box under the hood (driver's side in front of firewall). Remove junction box cover and locate the appropriate fused ignition power circuit (See table below).

Install fuse tapper onto fuse #49 and reinstall fuse. Connect the pink lead wire with flag connector to this new connection. Route wire out of the fuse box and close lid.



BATTERY JUNCTION BOX (BAB)

Fuse #49 (10AMP)

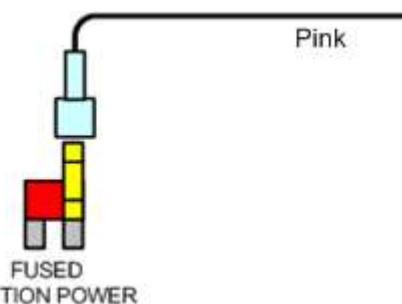

BD ENGINE BRAKE, INC.

Plant Address: A10-33733 King Rd, Abbotsford, BC, Canada V2S 7M9

US Shipping Address: 88-446 Harrison St, Sumas, WA 98295 US Mailing Address: PO Box 231, Sumas, WA 98295

Phone: 604-853-6096 Fax: 604-853-8749 Internet: www.bd-power.com

18. Double check all wiring connections and ensure wires are routed away from any heat sources and moving parts. Then install the loom with the supplied tee connector and clips for the loom ends and continue to the testing flow chart without over speed electronics in this manual.

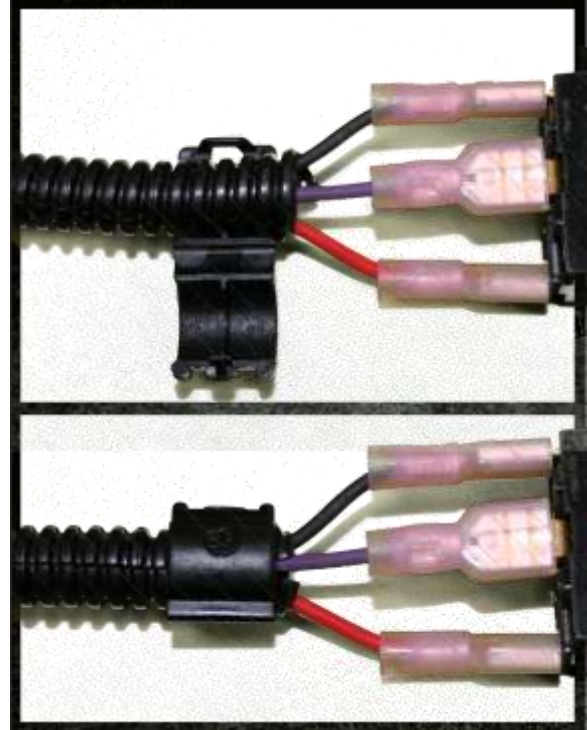
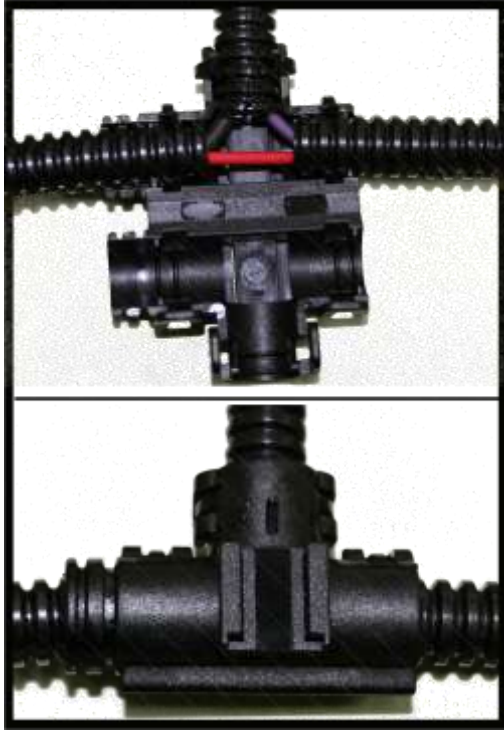

BEAD RING AND DRILL JIG INSTALLATION

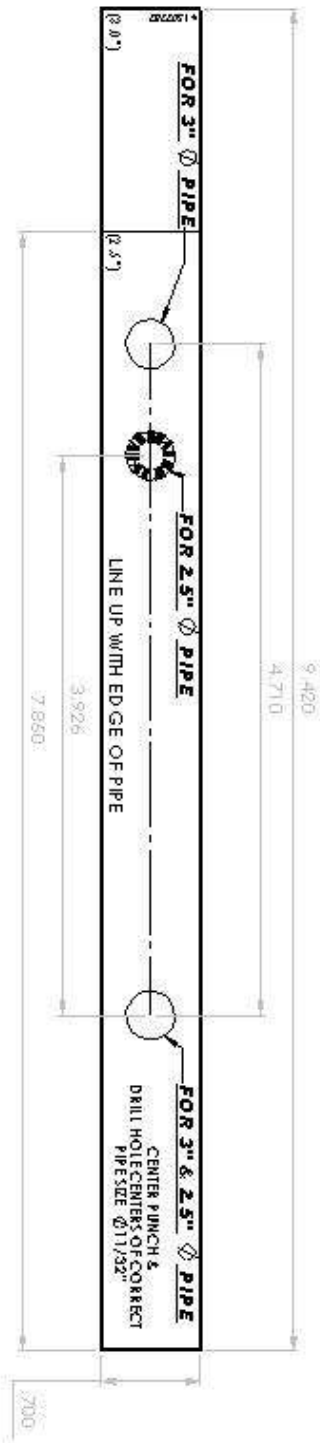

- WRAP CORRECT STICKER AROUND PIPE. LINE UP STICK EDGE WITH EDGE OF PIPE. MAKE SURE STICKER IS SQUARE AROUND PIPE AND BOTH ENDS CONNECT
- CENTER PUNCH CENTER OF MARKED HOLES
- USE CORRECT SIZE DRILL BIT AND DRILL THROUGH PIPE. ROTATE PIPE AND DRILL THROUGH SECOND MARKED HOLE. THE HOLES SHOULD BE PERFECTLY STRAIGHT
- REMOVE STICKER AND DEBURR INSIDE AND OUTSIDE OF PIPE
- THEN WRAP WIRE BEAD AROUND TUBE. YOU MAY NEED TO FORM IT SLIGHTLY. IF DONE CORRECTLY THE BEAD WILL NOT PULL OFF OF TUBE
- INSTALL SILICONE BOOT AND CLAMP AS YOU WOULD NORMALLY

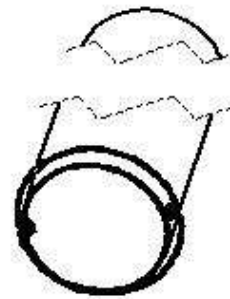
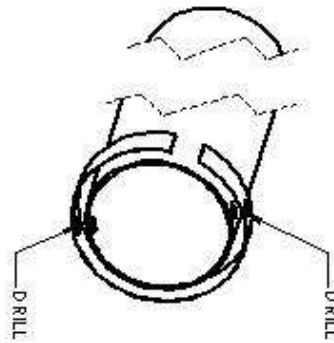

WIRING DIAGRAM without OVER SPEED ELECTRONICS (1036703-M)

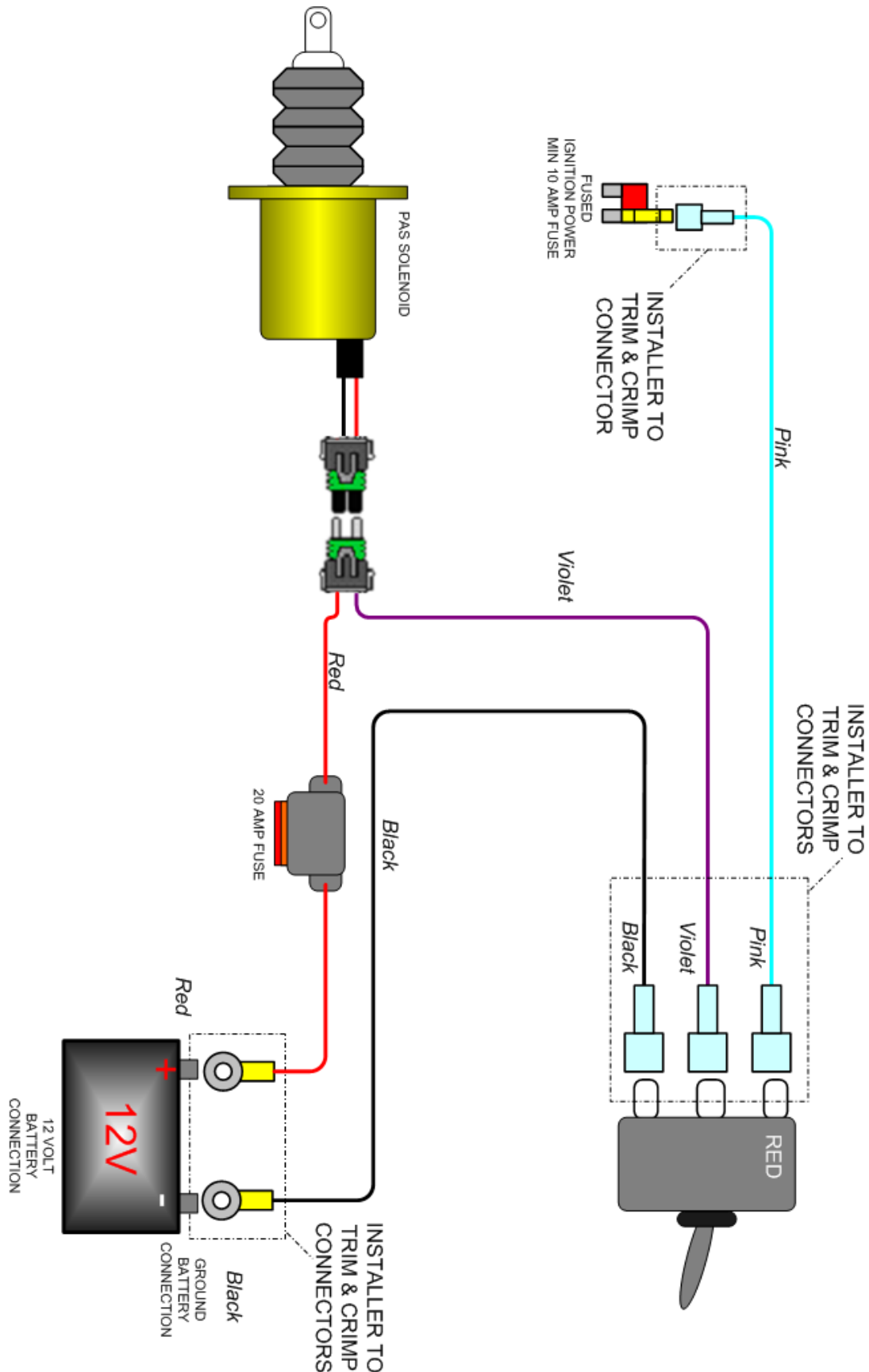

BD ENGINE BRAKE, INC.

Plant Address: A10-33733 King Rd, Abbotsford, BC, Canada V2S 7M9

US Shipping Address: 88-446 Harrison St, Sumas, WA 98295 US Mailing Address: PO Box 231, Sumas, WA 98295

Phone: 604-853-6096 Fax: 604-853-8749 Internet: www.bd-power.com

RESETTING THE VALVE

Valve Activated (Closed)

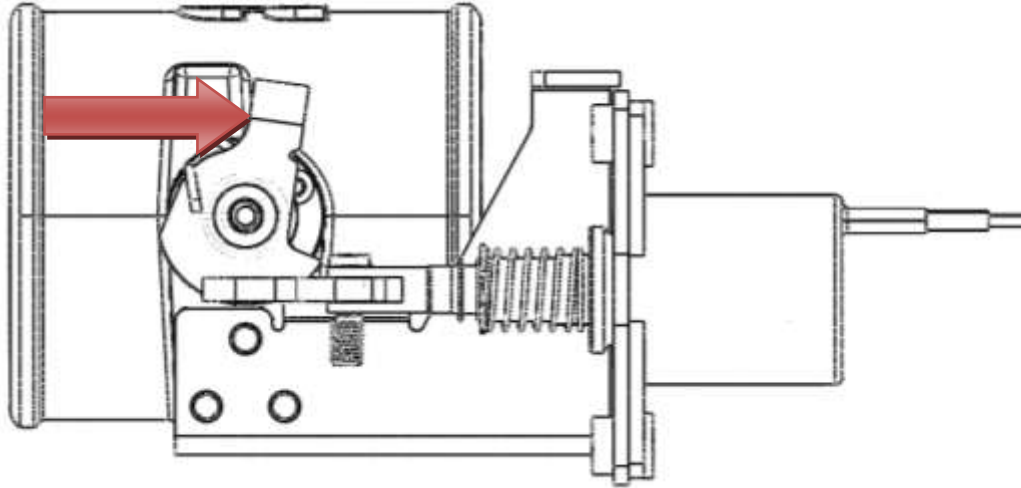

Valve Reset (Open)

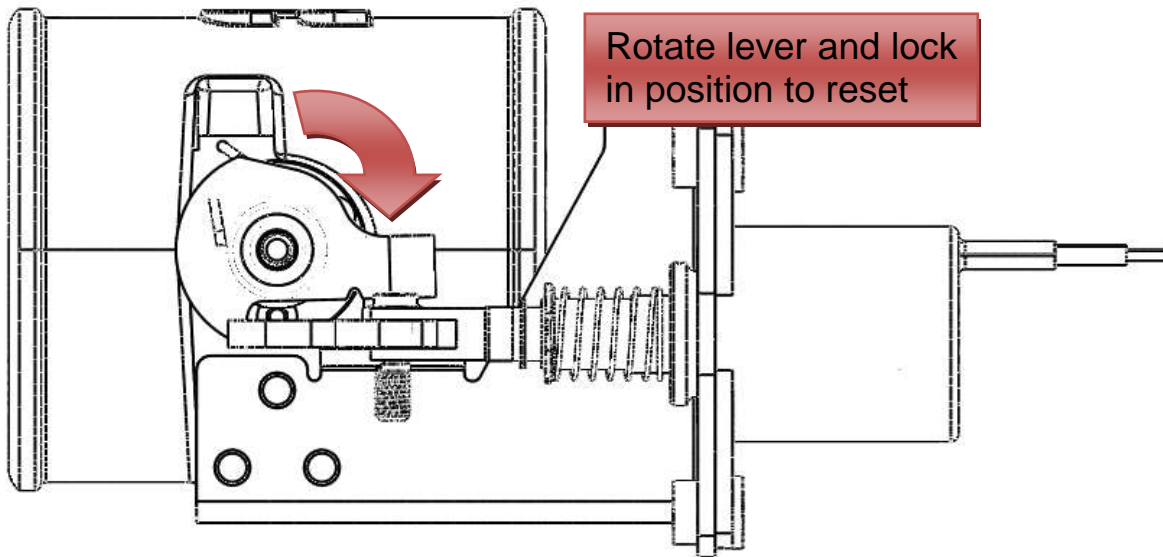

SETUP, TESTING AND VERIFICATION with OVER SPEED ELECTRONICS

Each unit is specifically configured for each model of truck. As in the case of different model years and makes the engine RPM frequency is different.	Engine Idle Speed Frequency 2011-2012 Ford 6.7L
	600-800 Hz (1.1:1) ratio

2011-2012 Ford Powerstroke	Activation RPM	Activation Freq. (Hz)
PAS Switch Position #1 (Automatic Mode)	5060	4600
PAS Switch Position #2 (Test Mode)	1320	1200
PAS Switch Position #3 (Manual Mode)	User Configured	User Configured

Automatic Mode (Pre Configured RPM)	
Action	Failure/Fix/Notes
1. Turn the ignition key to the on position. You should see the RED light illuminate on the toggle switch.	If the LED does not illuminate, check the wiring to the back of the switch first. Then check entire circuit.
2. Next, start the engine. 3. With the engine idling, activate the toggle switch. You should hear the solenoid activate and the valve close. The engine should die. Once the engine dies the switch should flicker ON and OFF indicating a trip condition.	If the engine does not die, check to make sure the valve actuated. If the valve did not actuate check switch and ground wiring. If valve did actuate but the engine is still running, ensure nothing has contacted the valve mechanism
4. You can now reset the valve, by rotating the upper lever and engaging the solenoid stop.	

5. With the valve reset, remove the outer enclosure from the control module. There are two locking tabs on the sides of the enclosure.

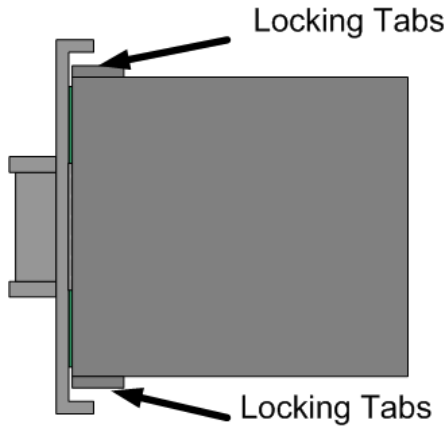

6. Change the position selection switch to position #2 (Auto Test). Slide enclosure cover over circuit board.

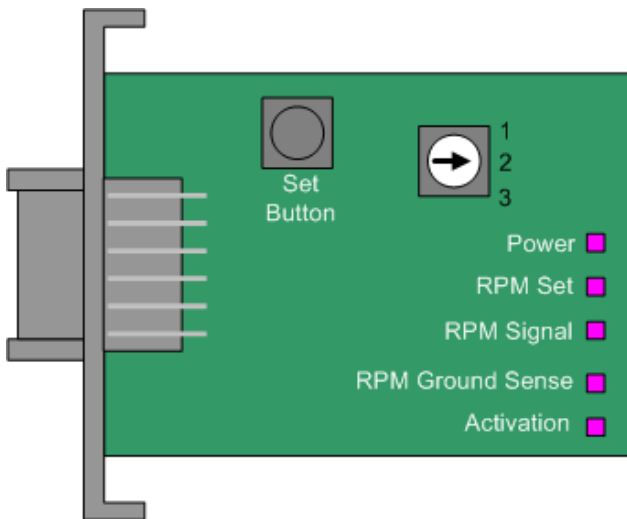

7. Start the vehicle, with the vehicle in park step on the throttle increasing the engine RPM. At 1320 RPM the PAS should engage itself automatically, and the engine should stall. Like with all activations the

If the engine did not stall, check to make sure the valve actuated. If the valve did not actuated, double check the engine RPM electrical connection. Check the RPM Signal LED on the circuit

toggle switch should flash.	board, it should flash proportionally to the engine RPM.
<p>8. Reset the valve and reset the mode position switch to position #1</p>	
<p>You are now complete and the unit should function correctly. This test cycle should be completed once a year.</p>	

Manual Mode (User Configured RPM)

Setup

With the control unit, the user/installer has the ability to set their own activation RPM. It is necessary that you chose a low activation RPM first to test the units is operating correctly. Once it has, you will need to set the high limit RPM activation.

Note: When you press the Set button the module will add 25% to the set speed.

1. Open electronic enclosure, by releasing the two locking tabs on the side of the unit.

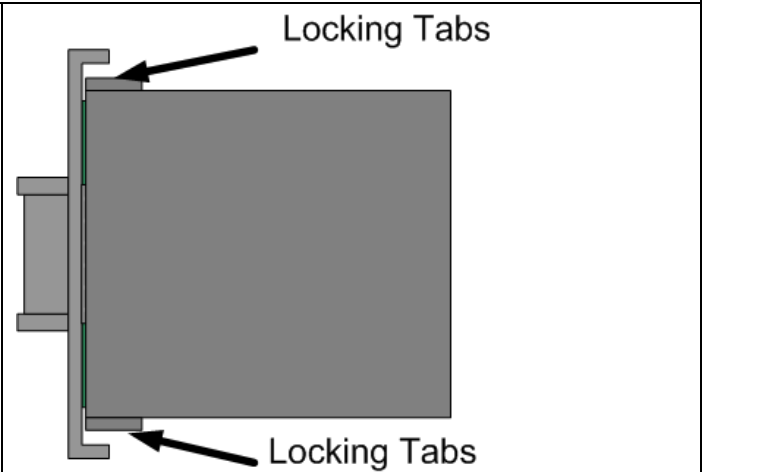

2. Adjust the position switch to Position #3.

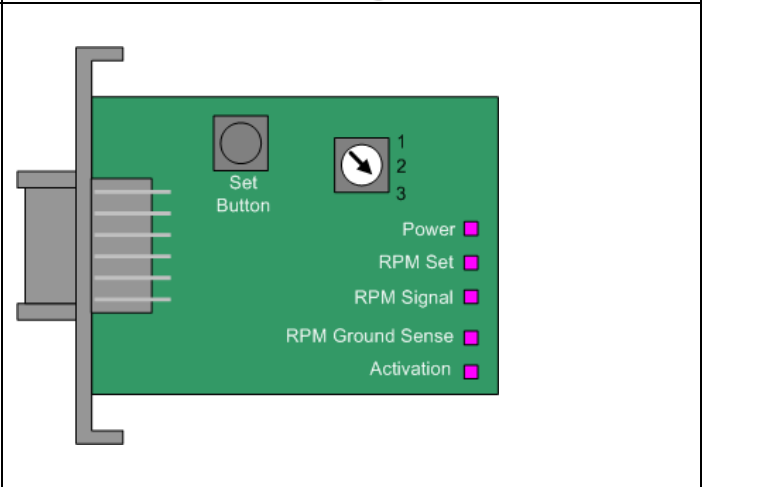
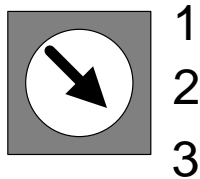

3. Start the engine.

4. Press and hold the RPM SET button.

When you push the SET RPM button will see the "RPM Set" LED illuminate.

5. With another person helping you, have them step on the accelerator with the vehicle in park. Raise the engine RPM to 1200 RPM.

6. Release the SET RPM button.

Upon releasing the button the unit will store the RPM + 25%. So for this example the unit has stored 1320 RPM + 25% = 1650 RPM.

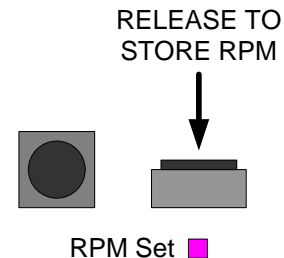
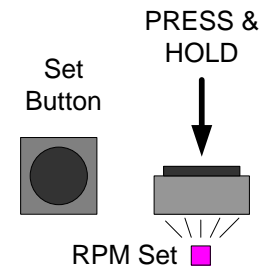

You should see the RPM signal flash proportionally to engine RPM.

7. Now increase the RPM of the engine to test the activation circuit is working correctly. As in this example the valve should activate at 1650 RPM.

You should see the ACTIVATION LED flash ON/OFF on activation.

If the valve does not activate check the wiring.

If the valve activates but the engine does not stall, ensure nothing has contacted the valve linkage.

8. With the valve activated the engine should die. Reset the valve and restart the engine.

9. Press and hold the RPM SET button.

When you push the SET RPM button will see the "RPM Set" LED illuminate.

10. With another person helping you, have

BD ENGINE BRAKE, INC.

Plant Address: A10-33733 King Rd, Abbotsford, BC, Canada V2S 7M9

US Shipping Address: 88-446 Harrison St, Sumas, WA 98295 US Mailing Address: PO Box 231, Sumas, WA 98295

Phone: 604-853-6096 Fax: 604-853-8749 Internet: www.bd-power.com

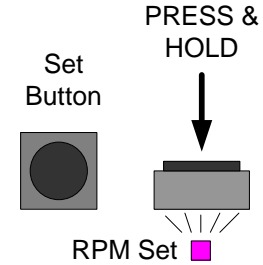
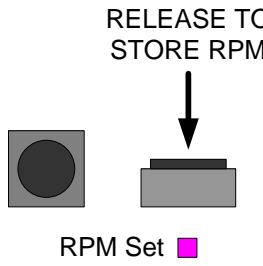
<p>them step on the accelerator with the vehicle in park. Raise the engine RPM to MAXIMUM engine RPM.</p> <p>11. Release the SET RPM button.</p> <p>Upon releasing the button the unit will store the RPM + 25%. So for this example the unit has stored MAXIMUM engine RPM + 25%.</p>	 
<p>12. You can now put the electronic enclosure back together and secure it to the fuse box.</p>	
<p>13. With the engine running you will need to test to make sure the manual activation switch is functioning correctly.</p> <p>14. With the engine running, lift the activation switch and the engine should die.</p> <p>15. Reset the valve and you are now complete.</p>	<p>If valve does not activate check the wiring.</p> <p>If the valve activates and the engine does not die ensure nothing has contacted the linkage.</p>
<p>You are now complete the installation, please be sure to complete the test once a year to make sure the unit is functioning correctly.</p>	

TESTING FLOW CHART with OVER SPEED ELECTRONICS

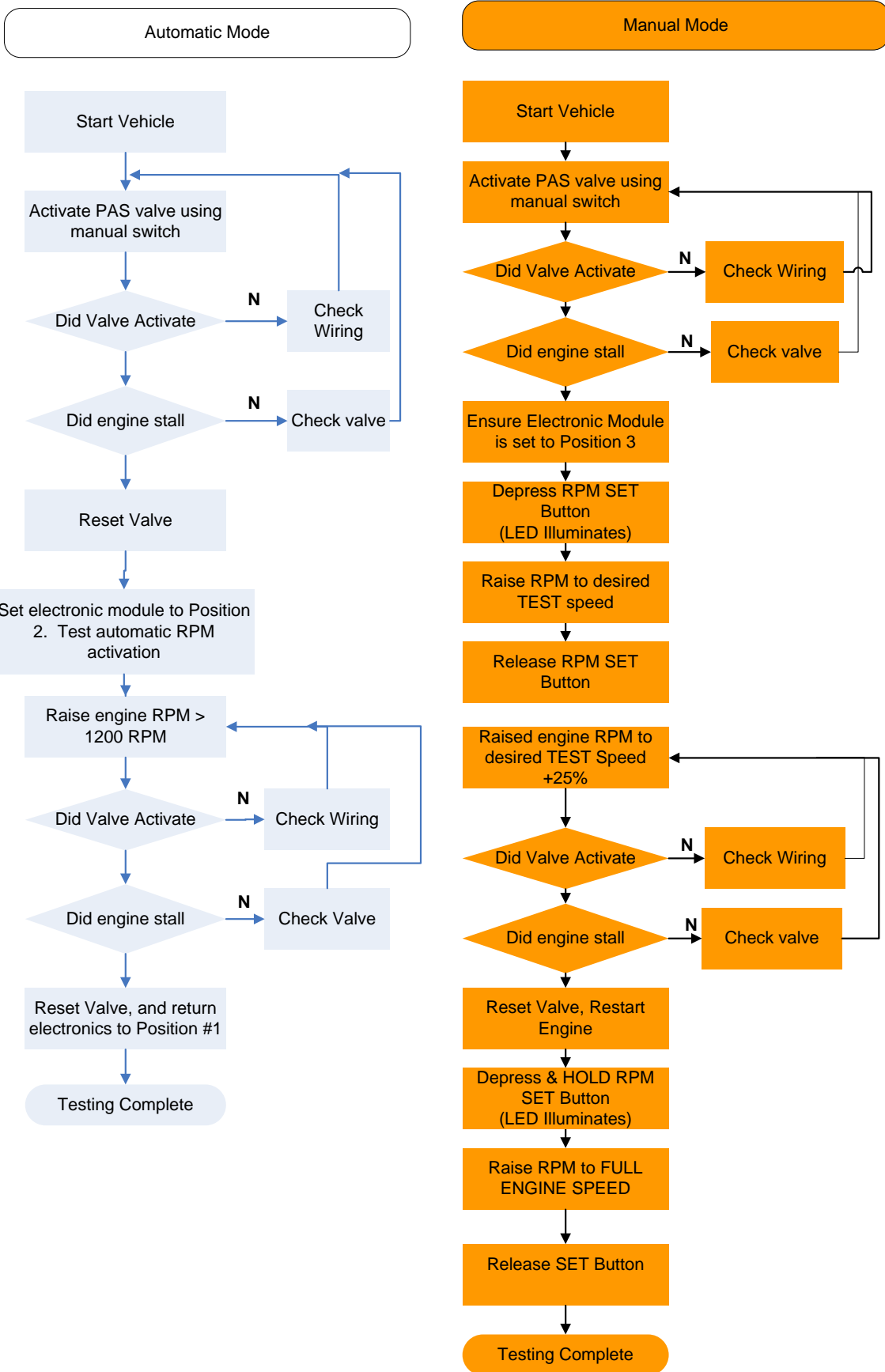

BD ENGINE BRAKE, INC.

Plant Address: A10-33733 King Rd, Abbotsford, BC, Canada V2S 7M9

US Shipping Address: 88-446 Harrison St, Sumas, WA 98295 US Mailing Address: PO Box 231, Sumas, WA 98295

Phone: 604-853-6096 Fax: 604-853-8749 Internet: www.bd-power.com

TESTING FLOW CHART without OVER SPEED ELECTRONICS

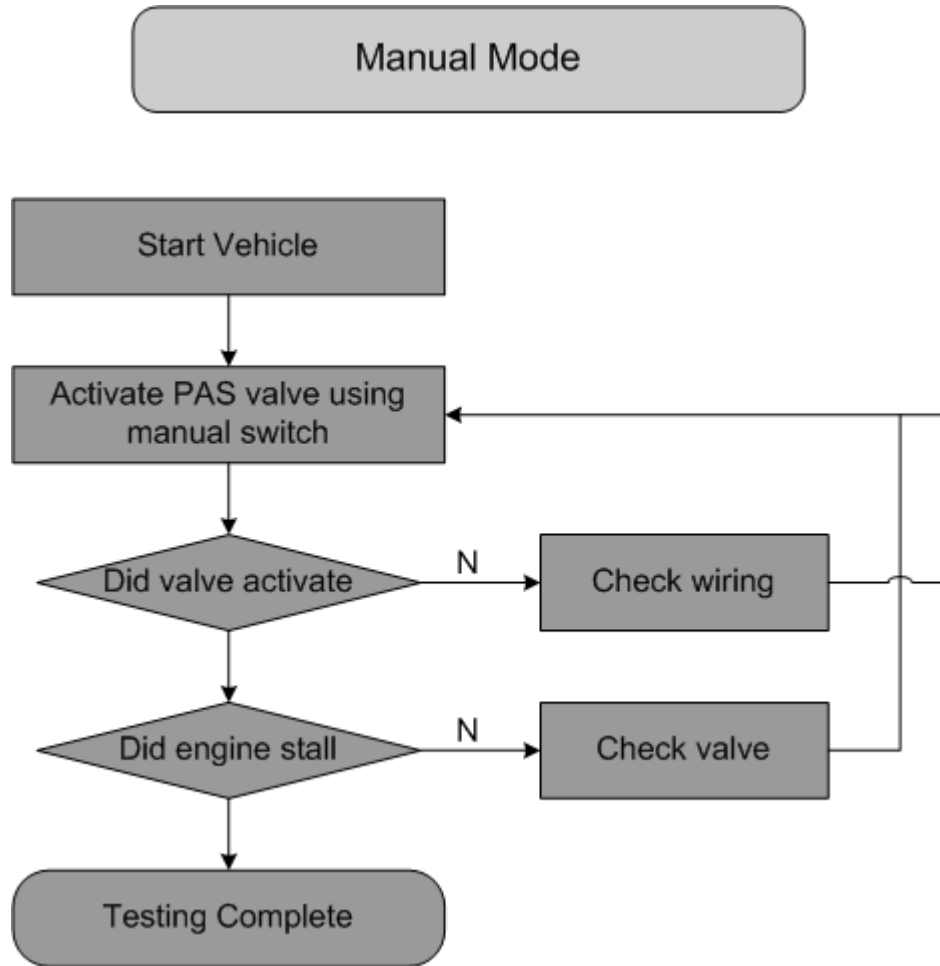

LED OPERATION

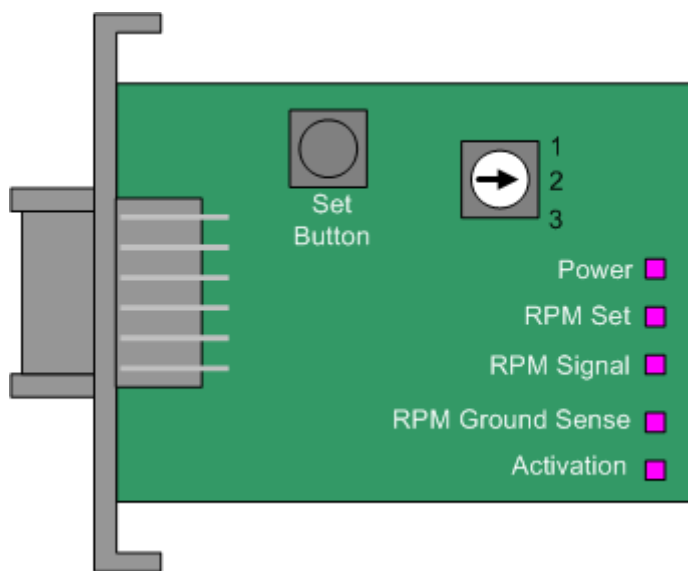

LED	Description
POWER	Illuminates when unit is POWERED
RPM SET	Illuminates when SET Button is Pressed
RPM Signal	Flashes proportional to Engine RPM
Ground Sense	Illuminates when a GROUND signal is sensed on the activation line or the solenoid is disconnected.
Activation	Flashes when a valve activation is command manually (switch) or automatically
Toggle Switch LED	The LED will flash indicating either a problem with the system (Loss of RPM or Power) or an activate valve activation.



Visit our Internet forums at <http://www.dieselperformance.com> and share your comments or technical support questions with some of the industry's leading experts in the diesel field.

If you have any technical difficulties, concerns, comments, or complaints, please phone our Technical Support hotline at (800) 887-5030 between 8:30am-5:00pm PST (Pacific Standard Time) Monday to Friday, or post a message on the BD Discussion Forums located at:

<http://forum.bd-power.com/>