

1988-2002 Dodge Cummins BD Turbo Mount Exhaust Brake

Part Number	Application
2033135	1988-1998 Dodge Cummins 12V (Micro Switch)
2033137	1999-2002 Dodge Cummins 24V (DFIV)

Serial # _____

Date Purchased _____

Purchased from _____

Installed by _____

***** Please read this manual before starting installation. *****

OWNER'S MANUAL - LEAVE IN GLOVE BOX

Install Manual Part # I2033135 – Printed in Canada

BD Engine Brake Inc.

Plant Address: Unit A10, 33733 King Rd, Abbotsford, BC, Canada V2S 7M9

U.S. Shipping: #88-446 Harrison St, Sumas, WA 98295 U.S. Mailing: P.O. Box 231, Sumas, WA 98295

Phone: 604-853-6096 | Fax: 604-853-8749 | Internet: www.dieselpower.com

TABLE OF CONTENTS

Welcome	3
Kit Contents.....	3
Pre-Installation	3
Stock Turbo Configuration Diagram	5
VALVE INSTALLATION	6
1988 to 1993 Dodge Cummins	6
1994 to 1998 Vehicles	6
1998½ to 2002 Vehicles	6
CONTROL KIT INSTALLATION	7
1988 to 1993 Vehicles	7
1994 to 2002 Vehicles	7
VACUUM SUPPLY	7
1988 to 1996 Vehicles	7
1997 to 2002 Vehicles	8
1997 to 2000 w/non-Vacuum Assist Booster	9
THROTTLE SWITCH INSTALLATION (1988-1998 Vehicles).....	9
1988 to 1993 Vehicles	9
1994 to 1997 Vehicles	10
DFIV INSTALLATION (1999-2002 Vehicles).....	11
Adjustment & Testing.....	12
2000 to 2002 (245HP HO 6 Speed):.....	13
HOSE & WIRING DIAGRAM (1988-1998 Dodges)	14
HOSE & WIRING DIAGRAM (1999-2002 Dodges)	15
POWER SWITCH INSTALLATION	16
Optional Shifter Switch (Push-Pull Style)	16
Optional Shifter Switch (Rocker Switch Style)	17
BRAKE TESTING	18
MAINTENANCE & TROUBLESHOOTING.....	18
AVAILABLE OPTIONS.....	19
SPOOL VALVE MAINTENANCE	19
Disassembly.....	19
Cleaning.....	20
Re-Assembly.....	20
Testing	20
HELPFUL HINTS	21
OPERATING GUIDELINES	21
Questions?	23
Limited Warranty Statement	24

Welcome

Thank you for purchasing a BD Exhaust Brake. This manual is divided into different areas to assist you with your installation and operation of your braking unit. We strongly suggest that you write down the kit and serial numbers of your unit in the spaces provided and retain this manual for any future reference.

**** Please fill out and mail registration card as soon as possible. ****

Kit Contents

2033135 - 1988-1998 Dodge Cummins 12V Exhaust Brake Kit

1	1230030	Vacuum Control Kit (w/ Micro Switch)
1	1230335	Vacuum Spool Valve Kit
1	2133030	Exhaust Brake

2033137 - 1998-2002 Dodge Cummins 24V Exhaust Brake Kit

1	1321039	DFIV (Idle Verifier) Application Kit
1	1230335	Vacuum Spool Valve Kit
1	2133030	Exhaust Brake
1	1130805	Dodge Brake Adapter Casting
1	1409591	Dodge Brake Adapter Clamp
1	1409592	Turbo Adapter Gasket

Pre-Installation

Before installation can begin, we must take a look at any other requirements or options for your particular application.

1993 and older Dodge trucks: A new BD Turbo Down Pipe (**Part # 1040050**) will be necessary for the brake install, due to the different position of the exhaust outlet with the brake installed on the turbo.

1988-1998 6BTA Dodges trucks: Heavy-duty valve springs (Kit Part # 1030060) must be installed before operation of Heavy Duty Exhaust Brake. Most trucks in these years come standard with 40# springs and they will not hold the back pressure created by this 60# exhaust brake system!

Serious engine damage could result if they are not installed!

This kit comes with a toggle switch for master power, but, as a desired option for manual transmissions, you may want to order a gear shifter switch kit. This kit is

BD Engine Brake Inc.

Plant Address: Unit A10, 33733 King Rd, Abbotsford, BC, Canada V2S 7M9

U.S. Shipping: #88-446 Harrison St, Sumas, WA 98295 U.S. Mailing: P.O. Box 231, Sumas, WA 98295

Phone: 604-853-6096 | Fax: 604-853-8749 | Internet: www.dieselpower.com

similar to the two-speed rear axle buttons used on highway tractors and aftermarket auxiliary transmissions, and makes for handy operation of the brake when in conditions of constant gear shifting. They are available in both a push/pull style and a “rocker” switch style. More information can be found later on in this installation manual. If the driver likes gauges, another handy option is the Brake Pressure Gauge Kit. This gauge will allow you to monitor the pressures being developed by the exhaust brake.

Unlike the manual transmission, automatic transmissions do not have a direct coupling between the transmission and engine. Therefore, efficient retarding cannot be obtained unless the engine is kept at a high R.P.M. by gearing down. There are two ways that either one of them, or both, will achieve easier operation and greater retarding performance out of the exhaust brake when used on an automatic transmission:

- 1) Better fluid coupling can be obtained with the installation of a **BD Torque Convertor** (call for correct part number), which will not only improve retarding performance at lower RPM's, but, will also transfer more torque to the rear tires, giving more pulling power and performance.
- 2) On **1994-2002 Vehicles**, BD has Torque Convertor Lock-Up kits available to keep the lock-up clutch in the convertor engaged to give direct coupling, just like a manual transmission. This will also reduce transmission temperature with exhaust brake use. Call BD for details.

BD Engine Brake Inc.

Plant Address: Unit A10, 33733 King Rd, Abbotsford, BC, Canada V2S 7M9

U.S. Shipping: #88-446 Harrison St, Sumas, WA 98295 U.S. Mailing: P.O. Box 231, Sumas, WA 98295

Phone: 604-853-6096 | Fax: 604-853-8749 | Internet: www.dieselpower.com

Stock Turbo Configuration Diagram

Stock Turbo Configurations

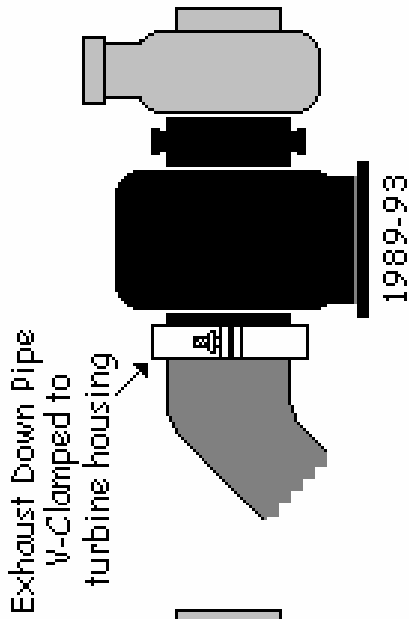
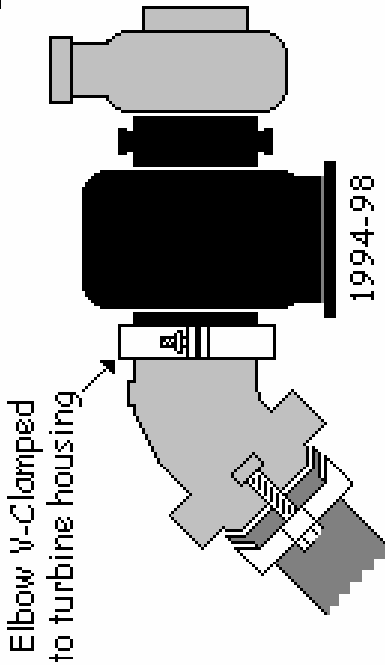
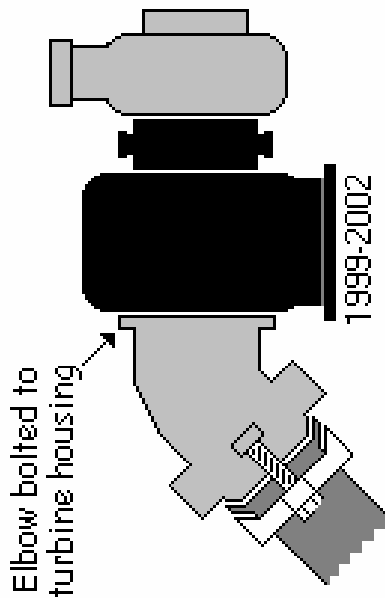

1999-2002 New Turbine Housing Adapter and Turbo V-Clamp supplied in 2033137 Kit

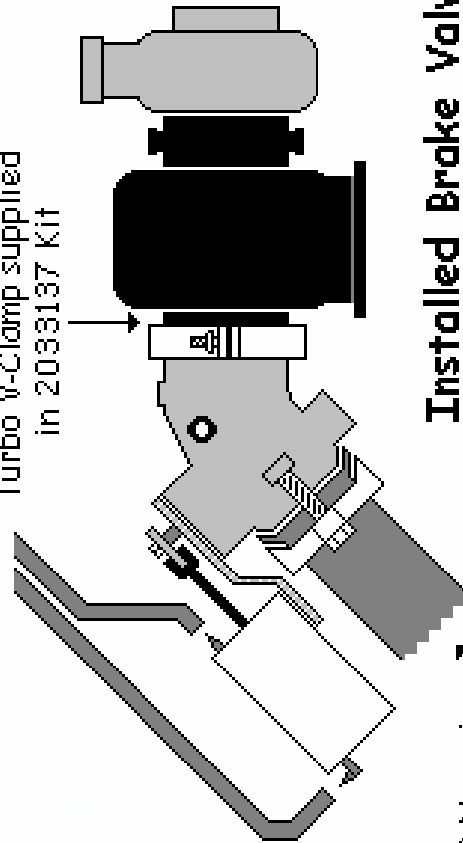

Installed Brake Valve

1989-93 New pipe from 1040050 Kit

BD Engine Brake Inc.

Plant Address: Unit A10, 33733 King Rd, Abbotsford, BC, Canada V2S 7M9

U.S. Shipping: #88-446 Harrison St, Sumas, WA 98295 U.S. Mailing: P.O. Box 231, Sumas, WA 98295

Phone: 604-853-6096 | Fax: 604-853-8749 | Internet: www.dieselpower.com

VALVE INSTALLATION

1988 to 1993 Dodge Cummins

From underneath the vehicle, remove the first hanger clamp and U-clamp on the down pipe coming from the turbo. Cut the pipe where the U-clamp was previously. Remove and retain the turbo exhaust clamp securing the exhaust down pipe to the turbo; inspect clamp to make sure the inner surfaces are not damaged. Remove old down pipe and clean any excess carbon build up on exhaust mating surfaces, checking for anything may cause problems with sealing.

Install Brake Valve Assembly on the turbo using original turbo exhaust clamp, while keeping enough clearance between Vacuum Cylinder, automatic transmission dipstick tube and engine exhaust manifold. Install new down pipe (Part # 1040050) with the flared end and mounting flange bolting up to the turbo, and the expanded end sliding over the existing intermediate pipe. Seal the joint of the two pipes with the supplied band clamp, and, reinstall old hanger clamp.

1994 to 1998 Vehicles

Remove cast exhaust elbow from turbo by removing turbo exhaust clamp and exhaust pipe flange bolts. Inspect turbo exhaust clamp, turbo down pipe and turbo outlet for any carbon build up or damage that may cause problems sealing on exhaust mating surfaces. (NOTE: Clamp bolts are metric.)

Install Brake Valve Assembly on the turbo using original turbo exhaust clamp, keep enough clearance between Vacuum Cylinder, automatic transmission dipstick tube, and engine exhaust manifold. Use the original turbo down pipe flange bolts to secure the pipe to Brake Valve Assembly. (NOTE: Some modification of the dipstick tube may be necessary.)

1998½ to 2002 Vehicles

Unbolt exhaust down pipe from turbo exhaust elbow. Unbolt and remove turbo exhaust elbow from turbo. Using the same bolts, install supplied adapter plate onto turbo. Torque bolts to 110 inch lb., then re-torque to 220-inch lb.

Install the exhaust brake assembly onto the turbo using the supplied turbo exhaust clamp. Keep enough clearance between the vacuum cylinder, automatic transmission dipstick tube and the engine exhaust manifold.

Secure the pipe to the exhaust brake using the original turbo down-pipe flange bolts. (NOTE: Some modification of the dipstick tube may be necessary)

BD Engine Brake Inc.

Plant Address: Unit A10, 33733 King Rd, Abbotsford, BC, Canada V2S 7M9

U.S. Shipping: #88-446 Harrison St, Sumas, WA 98295 U.S. Mailing: P.O. Box 231, Sumas, WA 98295

Phone: 604-853-6096 | Fax: 604-853-8749 | Internet: www.dieselpower.com

CONTROL KIT INSTALLATION

The Control Assembly has two hoses of unequal length attached to it. Push the longer hose onto the barb fitting on the back of the Vacuum Cylinder, and the shorter line onto the barb fitting on the front **Blue** cap. Maneuver the Control Assembly over to the driver's side of the engine, keeping the hoses out of the way of any moving or heated items on the engine.

1988 to 1993 Vehicles

Mount the Control Assembly onto the topside on the Extension Bracket (included in kit # 1040050) with the Control Valve wire w/stud (eye-hole) connector under the bolt, and, mount the bracket onto the Air Inlet Horn on the firewall side.

1994 to 2002 Vehicles

Mount the Control Assembly onto one of bolts of the air inlet on the driver's side of the engine with the Control Valve wire w/stud (eye-hole) connector under the bolt.

Caution!! Be sure to route all hoses and cabling away from any heat sources (i.e. exhaust manifolds) or any moving parts.

VACUUM SUPPLY

1988 to 1996 Vehicles

Cut the supplied vacuum supply hose w/plastic tee fitting that the overall length is approximately 14 inches, including tee fitting, so that it reaches the OEM line between the vacuum pump and brake booster. Moisten the free barbed fitting on the Control Valve Assembly and push the end of the hose without the plastic tee onto it.

Find the OEM hose running from the vacuum pump to the hydraulic brake booster. The supplied hose with plastic tee should reach to approximately 2 inches from the Power Booster Check Valve. Cut the OEM hose in a spot in which the plastic tee can reach, without interfering with moving or heated items around the engine compartment. Moisten the barbed ends of plastic tee and push the pieces of hose onto the plastic tee.

BD Engine Brake Inc.

Plant Address: Unit A10, 33733 King Rd, Abbotsford, BC, Canada V2S 7M9

U.S. Shipping: #88-446 Harrison St, Sumas, WA 98295 U.S. Mailing: P.O. Box 231, Sumas, WA 98295

Phone: 604-853-6096 | Fax: 604-853-8749 | Internet: www.dieselpowerperformance.com

1997 to 2002 Vehicles

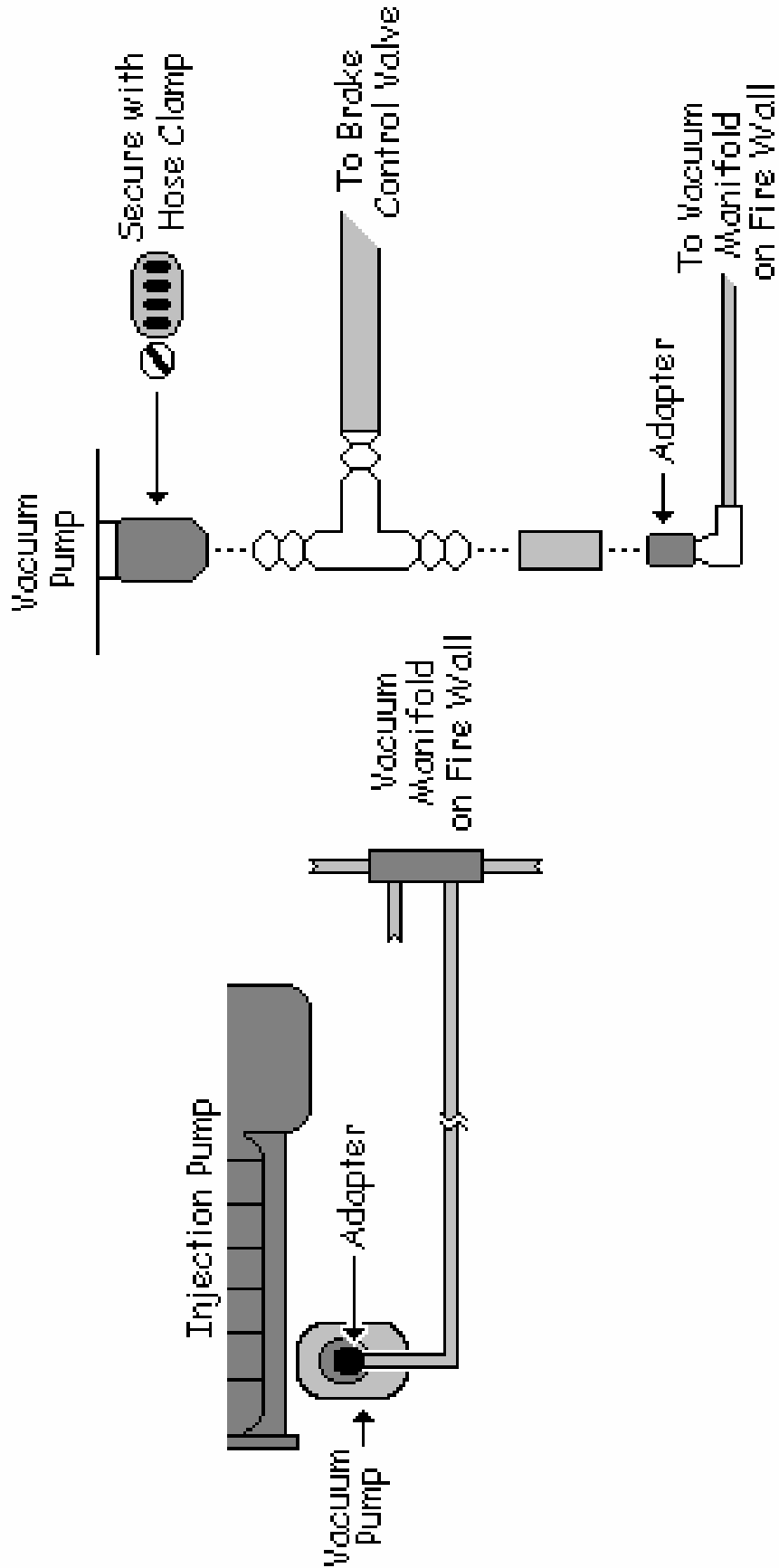

BD Engine Brake Inc.

Plant Address: Unit A10, 33733 King Rd, Abbotsford, BC, Canada V2S 7M9

U.S. Shipping: #88-446 Harrison St, Sumas, WA 98295 U.S. Mailing: P.O. Box 231, Sumas, WA 98295

Phone: 604-853-6096 | Fax: 604-853-8749 | Internet: www.dieselpower.com

1997 to 2000 w/non-Vacuum Assist Booster: Moisten the free barbed fitting on the Control Valve Assembly, and, push the end of the supplied hose without the plastic tee onto it. Run the hose to the injection pump area so that it does not interfering with moving or heated items in the engine compartment.

Locate the vacuum pump output, just below the injection pump. You will notice an adapter connected to the output with a length of small o/d tubing leading up to a vacuum manifold on the firewall.

Disconnect this adapter and hose from the rubber connector on the vacuum pump output.

Moisten barbs on the plastic tee and push the supplied 2-inch piece of hose onto the barb facing away from the engine. Then push the other end into the connector on the vacuum pump outlet and secure it with the supplied hose clamp. Push the OEM adapter w/small vacuum tubing into the other end of the supplied 2-inch piece of hose.

THROTTLE SWITCH INSTALLATION (1988-1998 Vehicles)

1988 to 1993 Vehicles

Mount the Throttle Switch onto the Throttle Switch Bracket. Remove the two top driver's side bolts, and throttle return spring bracket if present, on the front cover of the engine and mount the Throttle Switch Bracket on the front cover with the same bolts. If a throttle return spring was attached to the old bracket on the front cover, attach spring onto the hole by the top bolt on the Throttle Switch Bracket.

The silver button on the Throttle Switch should be resting against the throttle assembly so that it is fully depressed in the throttle's idle position. (NOTE: If throttle spring is weak, it may have to be replaced or additional spring added.)

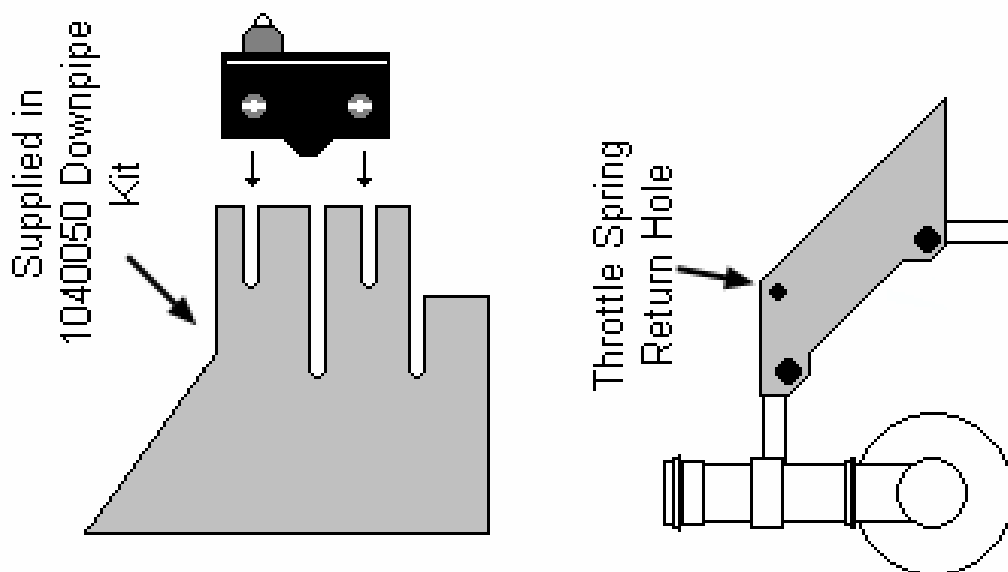

BD Engine Brake Inc.

Plant Address: Unit A10, 33733 King Rd, Abbotsford, BC, Canada V2S 7M9

U.S. Shipping: #88-446 Harrison St, Sumas, WA 98295 U.S. Mailing: P.O. Box 231, Sumas, WA 98295

Phone: 604-853-6096 | Fax: 604-853-8749 | Internet: www.dieselpower.com

1994 to 1997 Vehicles

NOTE: IF INSTALLING A BD TOWLOC WITH THIS BRAKE, DO NOT INSTALL THROTTLE SWITCH FROM THIS SECTION. FOLLOW THE TOWLOC DIRECTIONS FOR THE SWITCH TO CONTROL THIS BRAKE

At the throttle pedal in the cab of the pick-up, locate the nuts on the large aluminum bracket, just up from, and, to the left of the pedal. These nuts support the aluminum bracket on the firewall and are the mounting for the throttle and brake pedal. Remove the lower nut and loosen off the top nut. In the kit you will find the long Throttle Switch Bracket, which has two long slots for the Throttle Switch.

Slide the top end of the bracket (w/cut out slot) under the loosened upper nut and lay against the aluminum bracket so the stud that was exposed when you removed the lower nut protrudes through the other slot on the Throttle Switch Bracket. Screw lower nut back onto stud, but do not tighten nuts yet.

In the kit, find the small 2 3/8" long bracket with two holes. The arm of the throttle pedal starts off wide, then angles off into a thinner section further up the pedal. Just before the pedal's arm angles to the thinner section, place the middle hole of the bracket on the still wide section, close to the edge and angle the bracket towards the Throttle Switch on the other bracket you installed above.

Ensure sufficient clearance between the long Throttle Switch Bracket and the throttle pedal by sliding the bracket as far to the left as possible, to eliminate any possibility of pedal catching on bracket. Adjust both brackets so that the small bracket you are holding on the pedal arm is going to make good contact with the Throttle Switch with the pedal is in its resting/idle position.

When satisfied, mark and drill the two holes on the pedal arm and screw or pop rivet small bracket to arm. Tighten the nuts for the aluminum bracket and do final adjustments to Throttle Switch Bracket on the aluminum bracket.

Make sure the screws supporting the Throttle Switch and screws for the electrical wires on Switch are tight. Periodic adjustment to the Throttle Switch might be needed to maintain proper contact with Bracket on throttle pedal.

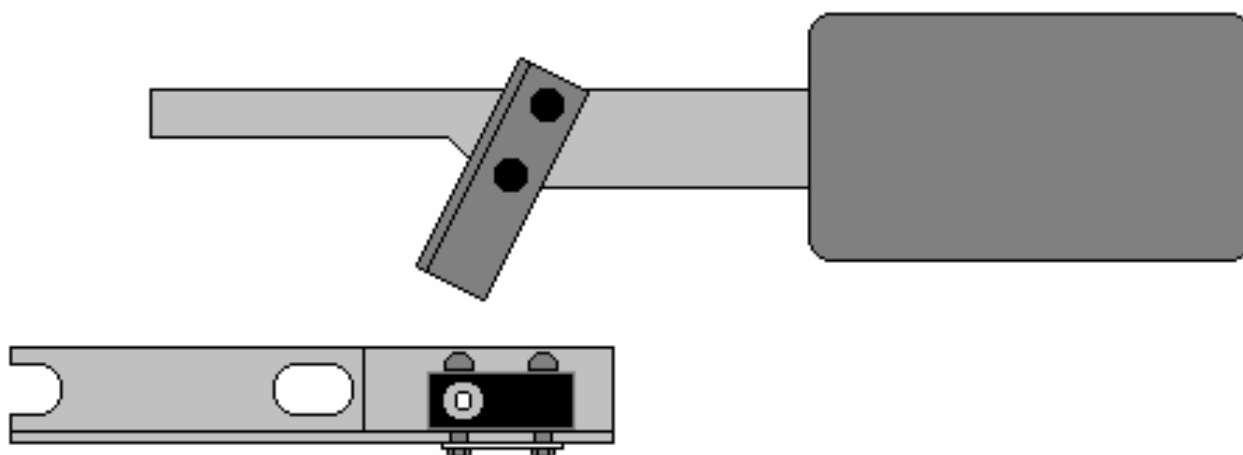

BD Engine Brake Inc.

Plant Address: Unit A10, 33733 King Rd, Abbotsford, BC, Canada V2S 7M9

U.S. Shipping: #88-446 Harrison St, Sumas, WA 98295 U.S. Mailing: P.O. Box 231, Sumas, WA 98295

Phone: 604-853-6096 | Fax: 604-853-8749 | Internet: www.dieselpower.com

DFIV INSTALLATION (1999-2002 Vehicles)

For all applications: Locate a grommet on the firewall and cut an opening in it to run the wiring through the firewall.

Route the Yellow wire from the DFIV module along the driver side of the engine to the throttle linkage and APPS Sensor.

Remove the cover of the throttle linkage then locate and disconnect the wiring connector for the APPS.

NOTE: This connector is located on the underside of the throttle linkage assembly and is in a difficult position.

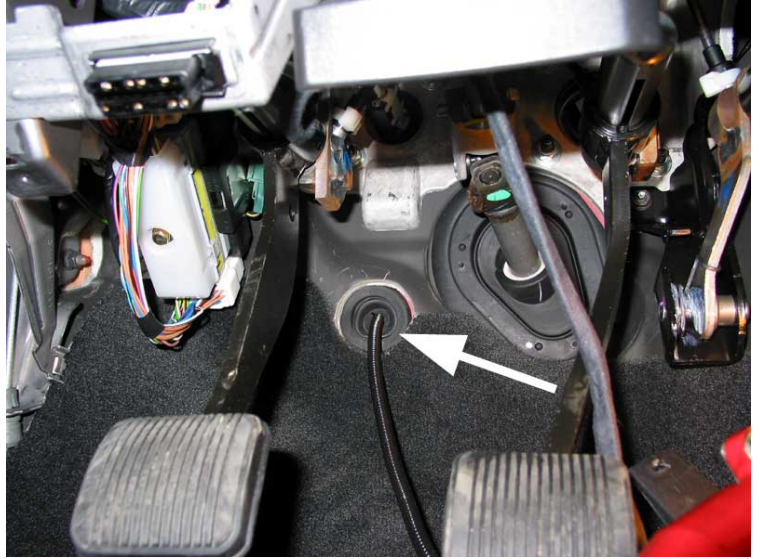

Open the loom and locate the Light Blue w/Black wire and install a gray Posi-Tap™ to it.

Connect the Yellow wire from the DFIV Module to this Posi-Tap™ and reconnect the APPS connector then reinstall the throttle linkage cover.

Throttle linkage cover removed



**APPS / TPS
Wiring
Harness**

BD Engine Brake Inc.

Plant Address: Unit A10, 33733 King Rd, Abbotsford, BC, Canada V2S 7M9

U.S. Shipping: #88-446 Harrison St, Sumas, WA 98295 U.S. Mailing: P.O. Box 231, Sumas, WA 98295

Phone: 604-853-6096 | Fax: 604-853-8749 | Internet: www.dieselpower.com

Adjustment & Testing

Ensure the connections of the corresponding wires to the DFIV Control Module are correct as shown in the wiring diagram.

To achieve the correct setting for the activation of the exhaust brake in relation to the throttle pedal the DFIV Module must be calibrated for your vehicle.

With the throttle at idle, start the engine and turn on brake switch. Then, using a small flat bladed screwdriver, turn the small adjusting screw in the DFIV Module counterclockwise or clockwise until the pump/brake JUST turns on.



CAUTION: THE ADJUSTING SCREW IS A MICRO-SWITCH WHICH IS VERY DELICATE, SO TURN USING SMALL ADJUSTMENTS.

Test by revving up the engine to approximately 1200 RPM and releasing the throttle. As the accelerator pedal is applied the brake should disengage just before then engine starts to rev, indicating proper calibration of the DFIV Module with the APPS.

Then the brake should activate again when the throttle pedal returned to idle. If not, readjust the DFIV Module so that it does.

Check for any exhaust leaks and recheck all connections and hoses for security and interference from moving or heated items. After about 100 miles (160 km), re-torque the flange bolts.

BD Engine Brake Inc.

Plant Address: Unit A10, 33733 King Rd, Abbotsford, BC, Canada V2S 7M9

U.S. Shipping: #88-446 Harrison St, Sumas, WA 98295 U.S. Mailing: P.O. Box 231, Sumas, WA 98295

Phone: 604-853-6096 | Fax: 604-853-8749 | Internet: www.dieselperformance.com

2000 to 2002 (245HP HO 6 Speed):

NOTE: IF INSTALLING A BD TOWLOC WITH THIS BRAKE, DO NOT INSTALL DFIV FROM THIS SECTION. FOLLOW THE TOWLOC DIRECTIONS FOR THE SWITCH TO CONTROL THIS BRAKE

To obtain access to the Cruise Control wiring harness remove the lower steering column panel by removing the mounting screws and unsnapping the panel from the instrument panel.

Under the dash running vertical by the left of the steering column, locate the smaller wiring harness that runs out of the main harness.

Remove some of the black electrical tape to gain access to the smaller wire bundle.

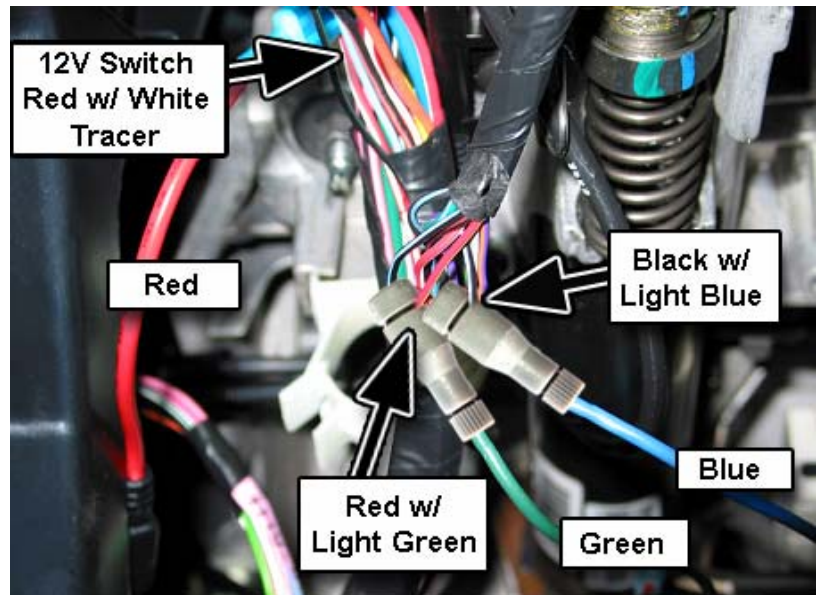

*****DANGER*****

THERE IS A BLACK WIRE WITH A TWISTED LIGHT BLUE/GREEN TRACER DO NOT CONNECT OR TEST THIS WIRE AS IT IS CONNECTED TO THE AIR BAG AND THE BAG MAY DEPLOY CAUSING DAMAGE AND/OR INJURY

*****DANGER*****

Remove some of the black electrical tape from the small bundle to gain access to the small Black wire with Light Blue tracer and install a gray Posi-Tap™ to it. Insert the Blue wire from the DFIV module into this connector.

In this same wiring harness, locate the Red wire with Light Green tracer and install another gray Posi-Tap™. Insert the Green wire from the DFIV module into this connector.

BD Engine Brake Inc.

Plant Address: Unit A10, 33733 King Rd, Abbotsford, BC, Canada V2S 7M9

U.S. Shipping: #88-446 Harrison St, Sumas, WA 98295 U.S. Mailing: P.O. Box 231, Sumas, WA 98295

Phone: 604-853-6096 | Fax: 604-853-8749 | Internet: www.dieselpower.com

HOSE & WIRING DIAGRAM (1988-1998 Dodges)

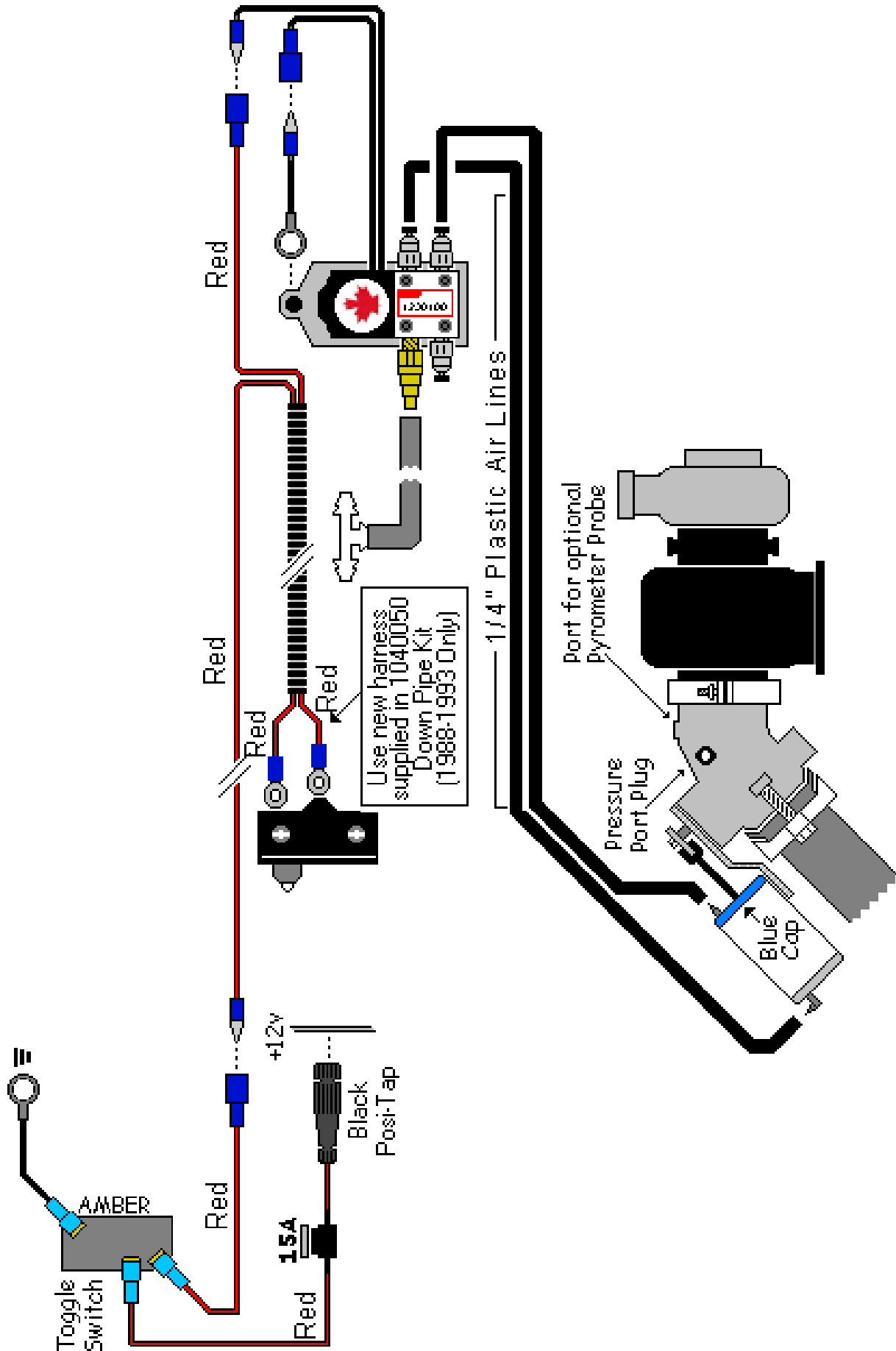

BD Engine Brake Inc.

Plant Address: Unit A10, 33733 King Rd, Abbotsford, BC, Canada V2S 7M9

U.S. Shipping: #88-446 Harrison St, Sumas, WA 98295 U.S. Mailing: P.O. Box 231, Sumas, WA 98295

Phone: 604-853-6096 | Fax: 604-853-8749 | Internet: www.dieselpower.com

HOSE & WIRING DIAGRAM (1999-2002 Dodges)

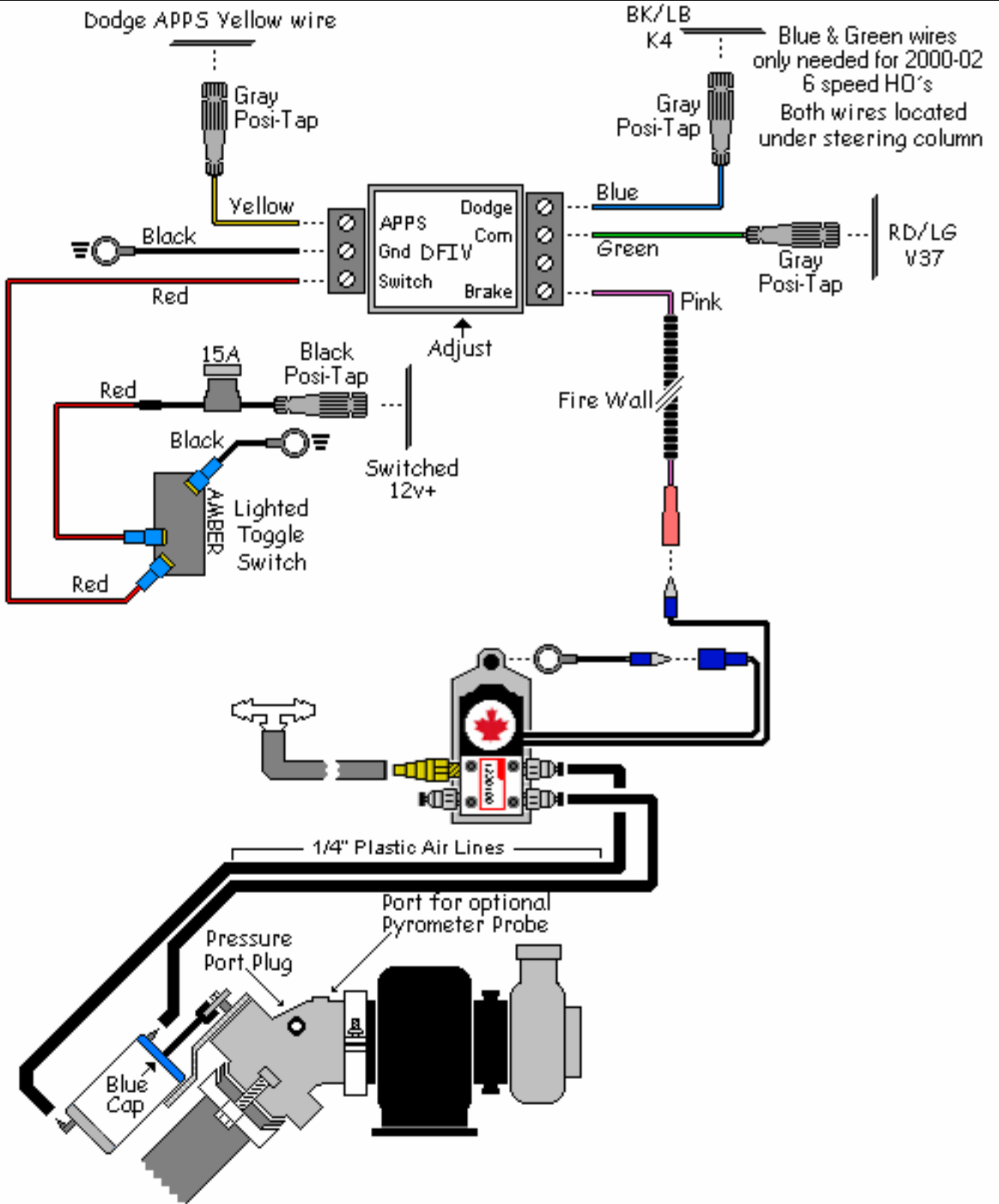

POWER SWITCH INSTALLATION

NOTE: IF INSTALLING A BD TOWLOC WITH THIS BRAKE, DO NOT INSTALL BRAKE SWITCH FROM THIS SECTION. FOLLOW THE TOWLOC DIRECTIONS FOR THE SWITCH TO CONTROL THIS BRAKE

Using the supplied line tapper, find a 12v ignition switch power source and attach the fused line of the Toggle Switch Wiring Harness to the power source. Locate the wiring grommet on the firewall and push the long wire through the grommet, with enough length to reach the Control Assembly without interfering with moving or heated engine parts. Plug the wire onto the free wire of the Control Assembly for 1994 to current vehicles, or the free wire on the Throttle Switch.

Locate a convenient spot for the Toggle Switch, keeping in mind the remaining distance available of the wiring harness and any moving parts under the dash. Plug the connectors of the wiring harness onto the Lighted Toggle Switch and mount switch. Ground the remaining wire (black) of the wiring harness.

Optional Shifter Switch (Push-Pull Style)

Mount the shifter switch onto the shift lever using the clamp supplied (either 5/8" or 3/4"). Run the electrical cable down the shifter shaft, securing the cable with zip-ties or electrical tape, and run it under the carpet to the firewall and under the dash to the relays, leaving enough slack for proper shifting of the transmission lever and to prevent any rubbing of wire.

At the end of the cable, cut off any excess and strip away about 1 to 2 inches of the black rubber covering exposing the black and white (or green) wires then strip the insulation from the ends of the two wires.

Connect the white (or green) wire to the "Switch" terminal on the DFIV Module.



Attach a male blade connector to the black wire. Remove the fused red wire from the toggle switch (the toggle switch and remaining red and black wire attached to the switch will no longer be needed) and attach to the black wire from the optional switch to the female connector of the fused Red wire from the toggle switch.

BD Engine Brake Inc.

Plant Address: Unit A10, 33733 King Rd, Abbotsford, BC, Canada V2S 7M9

U.S. Shipping: #88-446 Harrison St, Sumas, WA 98295 U.S. Mailing: P.O. Box 231, Sumas, WA 98295

Phone: 604-853-6096 | Fax: 604-853-8749 | Internet: www.dieselpower.com

Locate one of the ignition switched red/black tracer wires under the steering column (one is 10/12ga and the other is 14/16ga) and connect an appropriate Posi-Tap connector to it (green for 10/12ga and black for the 14/16ga wire) then connect the fused red wire to this Posi-Tap.

Optional Shifter Switch (Rocker Switch Style)

Mount the shifter switch onto the shift lever using the clamp supplied (either 5/8" or 3/4"). Run the electrical cable down the shifter shaft, securing the cable with zip-ties or electrical tape, and run it under the carpet to the firewall and under the dash to the relays, leaving enough slack for proper shifting of the transmission lever and to prevent any rubbing of wire.

At the end of the cable, cut off any excess and strip away about 1-2" of the black rubber insulation exposing the black, white and green wires, then strip the insulation from the ends of the three wires.

Connect the green 12V output green wire to the "Toggle Switch" input terminal on the DFIV Module.

Attach the 5/16" ring connector to the black ground wire and attach it to a good ground nearby.

Locate one of the ignition switched power fuses in the fuse panel underneath the steering column. Use the supplied fuse tap to supply ignition switched power to the "Keyed 12 Volts" (white) wire of the rocker switch assembly.

Also provided in the kit is a Posi-Tap connector as an alternative to the fuse tap and flag connector. If you want to use the Posi-Tap instead of using the fuse tap in the fuse panel, then you will need to locate a 12V switched ignition wire to power the switch. You could also use the 12V Switched Power source that powers the DFIV Module.

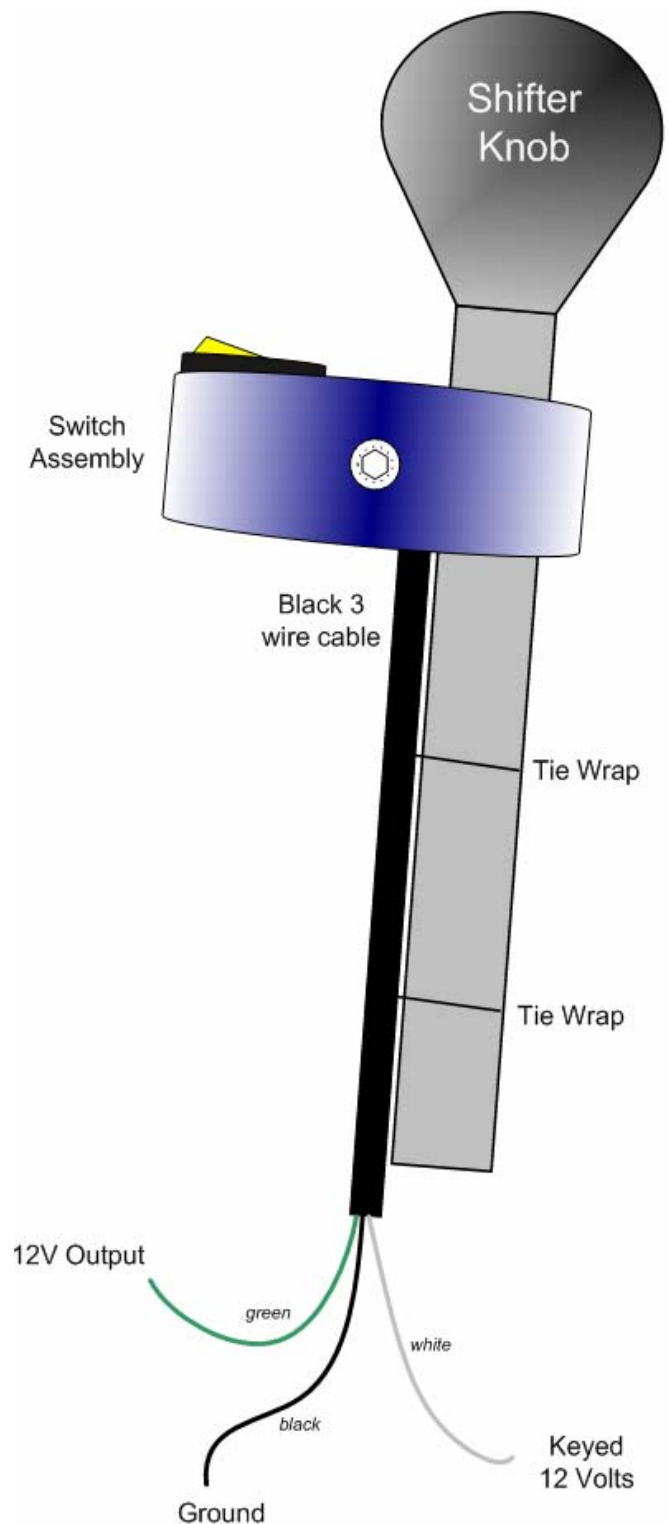

BD Engine Brake Inc.

Plant Address: Unit A10, 33733 King Rd, Abbotsford, BC, Canada V2S 7M9

U.S. Shipping: #88-446 Harrison St, Sumas, WA 98295 U.S. Mailing: P.O. Box 231, Sumas, WA 98295

Phone: 604-853-6096 | Fax: 604-853-8749 | Internet: www.dieselpower.com

BRAKE TESTING

Start engine and turn BD Engine Exhaust Brake on. Rev-up the engine to approximately 1200 R.P.M. and let go; the brake should have disengaged then activated again when the engine returns to idle. If did not, see if you can manually move the throttle pedal to see if it will come back far enough to depress the silver button on the Throttle Switch. If no, reposition the switch so it does.

On 1988-93, if the pedal can be moved more to activate the switch, then add a return spring (or second spring if it already has one) to the throttle assembly and hole on Throttle Switch Bracket.

Check for any exhaust leaks and recheck all connections and hoses for security and interference from moving or heated items. After about 100 miles (160 km), re-torque the turbo exhaust clamp and flange bolts.

The brake will need to be adjusted for the vehicle. If more holdback performance is required with the vehicle loaded, adjust the rod on the Vacuum Cylinder to close off the valve tighter.

NOTE: Only slight adjustments are required to gain desired effect, and, all adjustments should be done with vehicle turned off.

It is required that a standard pressure gauge be used to make the necessary adjustments to the brake valve. Adjust the brake to reach approximately 20-25 lb. on 24 Valve ISB motors and on 12 Valve 6BTA motors that have had the exhaust valves spring changed. For 12 Valve 6BTA motors that still have the stock exhaust valve springs, adjust the brake to 10-15 lb. when the engine is at idle.

NOTE: Over the two weeks, the back pressure at idle may rise due to initial carbon build-up, the brake valve will need to be adjusted again.

MAINTENANCE & TROUBLESHOOTING

To extend life of Valve Assembly, do not operate vehicle for extended periods of time without activating the Brake. We suggest activating the Brake at least a couple times on any day you operate the vehicle, to prevent any carbon or rust build up on inner parts of the Valve Assembly.

The hoses, wires, fittings and clamps should be inspected on a regular basis for any deterioration, damage or leaks. The position of the Throttle Switch may have to be adjusted, depending on condition of throttle linkages and return springs.

BD Engine Brake Inc.

Plant Address: Unit A10, 33733 King Rd, Abbotsford, BC, Canada V2S 7M9

U.S. Shipping: #88-446 Harrison St, Sumas, WA 98295 U.S. Mailing: P.O. Box 231, Sumas, WA 98295

Phone: 604-853-6096 | Fax: 604-853-8749 | Internet: www.dieselperformance.com

Due to heat around the Exhaust Valve, we recommend that the vacuum hoses to the Control Valve be replaced every 12 to 24 months.

Periodically clean the filter on the Control Valve, and, when cleaning the engine, cover the Control Valve to prevent moisture from entering filter. Following the diagrams in this manual, tracing hoses and wiring, checking continuity through electric components or checking for any lines that are disconnected, should solve any problems that may arise.

To increase the life of your exhaust brake we recommend daily operation. This could simply be switching it on and off a couple times a day and will prevent the butterfly from sticking due to carboning up.

AVAILABLE OPTIONS

Turbo Down Pipe for Brake install on 1988-93	1040050
60# Exhaust Valve Spring Kit	1030060
Manual Transmission Shifter Switch Kit	Call
AutoLoc - Convertor Lock-up Clutch Kit	1030390
TowLoc Performance Lock-up Kit	Call
Performance Torque Converters	Call
Exhaust Temperature Gauge (Pyrometer) Kit	1030512
Boost Pressure Gauge Kit (30#)	1030570
Transmission Gauge Kit (Auto Trans)	Call
Brake Back Pressure Gauge Kit	1030550

SPOOL VALVE MAINTENANCE

Disassembly

- Remove the two coil screws.
- Remove the two rear plate screws.
- Pop out the white and black bumpers, springs, and O-rings.
- Remove the spool and sleeve assembly from the valve body with a plastic or wooden rod approximately the same size as the outside diameter of the sleeve.

BD Engine Brake Inc.

Plant Address: Unit A10, 33733 King Rd, Abbotsford, BC, Canada V2S 7M9

U.S. Shipping: #88-446 Harrison St, Sumas, WA 98295 U.S. Mailing: P.O. Box 231, Sumas, WA 98295

Phone: 604-853-6096 | Fax: 604-853-8749 | Internet: www.dieselperformance.com

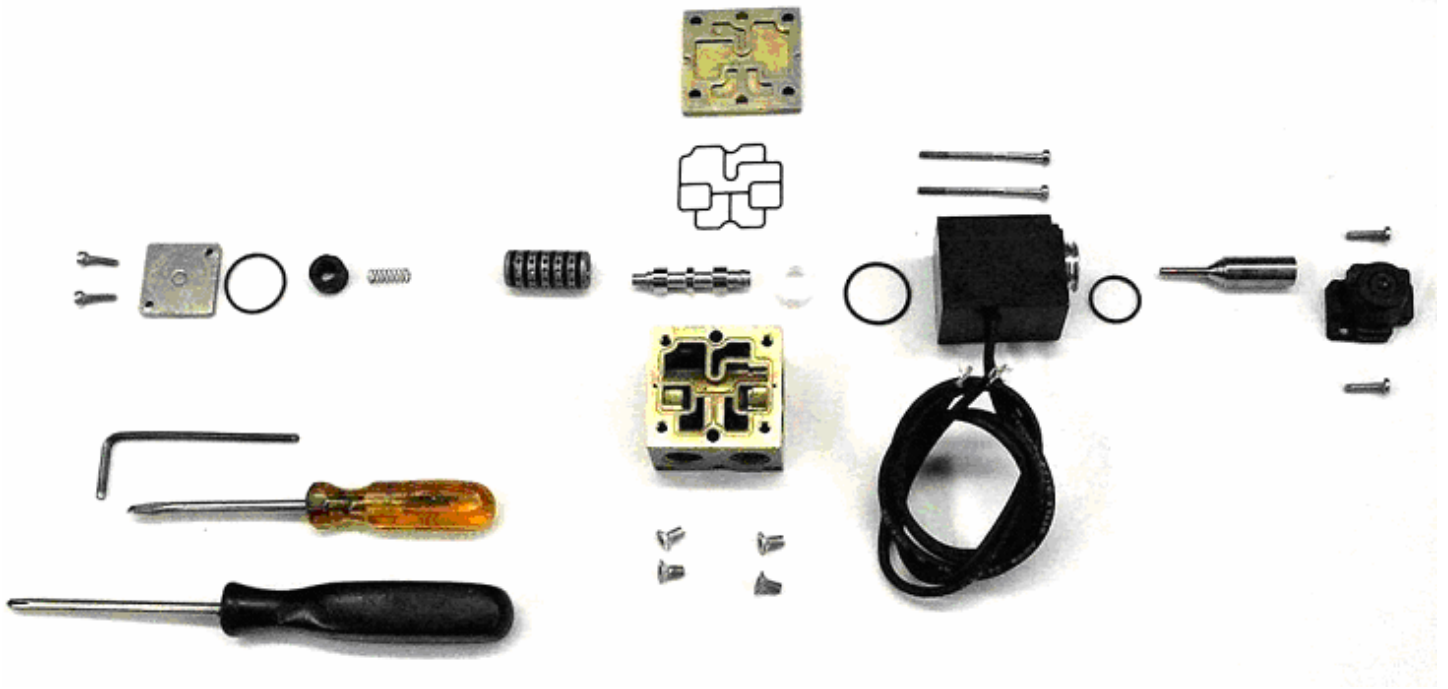

Cleaning

- Clean the spool and sleeve with some WD40 and compressed air.
- Inspect the spool and sleeve for any damage and inspect O-rings.
- The spool should move freely within the sleeve.

Re-Assembly

- Re-install the rear plate, O-ring, and black bumper onto the body.
- Gently slide the sleeve into the body cavity by pushing and turning at the same time.
- Drop the spring into the sleeve.
- Gently insert the spool into the sleeve with a slow, turning action. NOTE: The residual WD40 should be enough lubricant for assembly.
- Check to ensure that there is very little resistance felt when it's inserted. NOTE: If any resistance or binding is noted, remove the spool and try again.
- Once the spool is inserted and moving freely, reattach the coil, white bumper, and O-ring.

Testing

- After reassembly is completed, push and release the manual override button. The spool should move and return freely.

BD Engine Brake Inc.

Plant Address: Unit A10, 33733 King Rd, Abbotsford, BC, Canada V2S 7M9

U.S. Shipping: #88-446 Harrison St, Sumas, WA 98295 U.S. Mailing: P.O. Box 231, Sumas, WA 98295

Phone: 604-853-6096 | Fax: 604-853-8749 | Internet: www.dieselpower.com

- If you have an air compressor, blow low-pressure (20-30 psi) air into Port #1, then push the override button. There should be a transfer of flow from Port #2 to Port #4.
- Re-install the valve on the engine, hook up the disconnected vacuum lines and wiring, then check for correct operation of Brake, PressureLoc, etc.

HELPFUL HINTS

Make sure all parts are spread out on a clean, lint-free surface while servicing valve.

****CAUTION**** Do NOT use heavy grease or oils on the spool, sleeve, or O-rings. (Oil based lubricants will swell and distort rubber O-rings).

Do not use any abrasive compounds on the spool or the sleeve.

Make sure all of the O-rings are re-installed and are in good condition by checking for nicks, scoring, or other damage.

OPERATING GUIDELINES

Thank you for taking interest in the BD Engine Exhaust Brake. As a driver, you probably already know the need for extra braking power that your vehicle requires on the hills and long grades. With loads being towed behind you, the extra push when slowing down or maintaining speed on downward grades can prove to be a strain on the vehicle's hydraulic braking system, even to the point of "burn-up".

These guidelines were designed to offer you a better understanding of the benefits of exhaust brakes and are partly based upon material developed by the U.S. Department of Transportation National Highway Traffic Safety Administration.

The emphasis on today's vehicles is to give the consumer a product that can give them usable power with fuel efficiency. But, in the transition, the vehicles have lost their natural braking power, making it more easy for the vehicle to continue to roll and harder to stop. Of course, this gets more noticeable with the increase of weight, on or behind the vehicle. This is where an exhaust brake becomes a useful tool in increasing the driveline drag of the vehicle without the use of the hydraulic brakes and with maximum use or even occasional use, can reduce wear on hydraulic braking parts and at the same time increase safety.

The BD Exhaust Brake can be used to help maintain a controlled vehicle speed on a downward grade, as well as slowing the vehicle down for such times as turns or exit ramps, without you using your hydraulic brakes. **However, the exhaust brake cannot be used as a parking brake or will not bring your vehicle to a complete stop.**

BD Engine Brake Inc.

Plant Address: Unit A10, 33733 King Rd, Abbotsford, BC, Canada V2S 7M9

U.S. Shipping: #88-446 Harrison St, Sumas, WA 98295 U.S. Mailing: P.O. Box 231, Sumas, WA 98295

Phone: 604-853-6096 | Fax: 604-853-8749 | Internet: www.dieselpower.com

By using a BD Exhaust Brake, the life and effectiveness of your hydraulic brakes will increase. This is because of the decreased use of the hydraulic brakes in situations like hills, the wear factor is reduced and there is less opportunity for your hydraulic brakes to heat up which would reduce the efficiency. When you ride your hydraulic brakes, make hard stops or have poorly adjusted brakes, this creates high temperatures and as your brakes get hotter, the more chance there is for fade or failure.

With terrain that is a series of up and down grades, the BD Exhaust Brake will aid in reducing exhaust valve warpage. Because of the power needed to pull your vehicle and load up a hill, this generates a lot of heat. When you have reached the crest of the hill and are now coasting down the other side, the heated valves are too quickly cooled. With the exhaust brake engaged, the heat loss to the valves will be reduced, which can prevent valve warpage.

When the toggle switch is turned to the "On" position, the valve is activated every time the driver takes his foot off of the throttle pedal. When the driver puts pressure back on the throttle pedal, the Micro switch is deactivated and the valve opens again. Exhaust brakes are designed to operate with the throttle at idle, not to be used in conjunction with cruise controls, and not designed to aid in gear shifting. Such cases could cause damage to engine and/or the exhaust brake. Incorporated with the BD Exhaust Brake, there is a pressure regulating system that will control the created backpressure. If the backpressure reaches the set limit, the exhaust valve will open slightly to relieve the excess pressure. **The brake pressure at idle is required to be checked and adjusted at time of installed, two weeks after installed, and on a regular twice a year interval.**

If you have purchased a system that is rated for the stock engine exhaust valve springs, and you later decide to update to the heavy duty exhaust valve springs, you will have to adjust the brake pressure to 20-25lb at idle. **Never adjust the brake to the 60 lb. setting on an engine that has not had the heavy-duty engine exhaust valve springs installed first.**

The best scenario for exhaust braking is when going down hill, select a gear that lets you maintain a constant speed with little or no use of the hydraulic brakes, or the same gear that would be used to go up the same grade of hill. This also depends on the weight, load or road conditions that the vehicle will come upon.

So, in summary, by using the BD Exhaust Brake, you reduce the need for use of your hydraulic brakes in situations where you need to slow down or maintain (i.e. hills, off ramps, corners, approaching speed changes or traffic lights). Reducing the use of your hydraulic brakes in these situations will reduce the heat build up, as well as wear and damage to linings and drums. And, when you reduce these factors, you save your hydraulic brakes for when you really need them (for stopping or emergencies).

BD Engine Brake Inc.

Plant Address: Unit A10, 33733 King Rd, Abbotsford, BC, Canada V2S 7M9

U.S. Shipping: #88-446 Harrison St, Sumas, WA 98295 U.S. Mailing: P.O. Box 231, Sumas, WA 98295

Phone: 604-853-6096 | Fax: 604-853-8749 | Internet: www.dieselpower.com

The BD Exhaust Brake is not a substitute for your hydraulic brakes and, cannot correct or compensate for poorly maintained or misadjusted brakes. But, when you need to slow down or maintain a constant speed, the BD Exhaust Brake will be a valuable and effective tool. Exhaust Brakes are more efficient at preventing than correcting an over speed condition.

Questions?

Thank you for purchasing the BD Exhaust Brake, please check out our web site at www.bd-power.com for other products such as BD PressureLoc, BD TowLoc or for info on our Performance Transmissions and components please call, fax or E-mail our **BD Technical Service or Sales Department**, 8:30am to 4:30pm Pacific Time, Monday to Friday.

BD Engine Brake Inc.

Plant Address: Unit A10, 33733 King Rd, Abbotsford, BC, Canada V2S 7M9

U.S. Shipping: #88-446 Harrison St, Sumas, WA 98295 U.S. Mailing: P.O. Box 231, Sumas, WA 98295

Phone: 604-853-6096 | Fax: 604-853-8749 | Internet: www.dieselperformance.com

BD Engine Brake

Limited Warranty Statement

THE INSTALLATION OF THIS PRODUCT INDICATES THAT THE BUYER HAS READ AND UNDERSTANDS THIS AGREEMENT AND ACCEPTS ITS TERMS AND CONDITIONS.

DISCLAIMER OF LIABILITY

BD Engine Brake Inc., its successors, distributors, jobbers, and dealers (hereafter "**BD**") shall in no way be responsible for the product's proper use and service. THE BUYER HEREBY WAIVES ALL LIABILITY CLAIMS.

BD disclaims any warranty and expressly disclaims any liability for personal injury or damages. **BD** also disclaims any liability for incidental or consequential damages including, but not limited to, repair labor, rental vehicles, hotel costs, or any other inconvenience costs by reason of use or sale of any such equipment. The **BUYER** acknowledges and agrees that the disclaimer of any liability for personal injury is a material term for this agreement and the **BUYER** agrees to indemnify **BD** and to hold **BD** harmless from any claim related to the item of any equipment purchased.

This warranty shall not apply to any unit that has been improperly stored or installed, or to misapplication, improper operation conditions, accidents, neglect, or which has been improperly repaired or altered or otherwise mistreated by the **BUYER** or his agent. **BD** also assumes no liability regarding the improper installation or misapplication of its products. It is the installer's responsibility to check for proper installation and if in doubt, contact the manufacturer.

LIMITATION OF WARRANTY

BD Engine Brake Inc. (hereafter "**BD**") warrants to the **BUYER** that any parts purchased shall be free from defects in material workmanship. A defect is defined as a condition within the product that would render the product inoperable. **BD** gives Limited Warranty as to description, quality, merchantability, fitness for any product's purpose, productiveness, or any other matter of **BD's** product sold herewith. **BD** shall be in no way responsible for the product's open use and service and the **BUYER** hereby waives all rights other than those expressly written herein. This Warranty shall not be extended or varied except by a written instrument signed by **BD** and the **BUYER**.

This Warranty is Limited to two (2) years from the date of sale. Labor costs incurred by the removal and replacement of the BD product, while performing warranty work, will be covered for 1 (one) year, payable at BD rates, at authorized centers and with prior approval. Until BD has approved the claim, the consumer may be responsible for these costs.

A Return Authorization (WA) number, obtained in advance from **BD**, must accompany all products returned for warranty consideration. All products must be returned, shipping prepaid, to **BD** and must be accompanied by a dated proof of purchase receipt. All Warranty claims are subject to approval by **BD** and repaired or replaced product will be returned to the customer freight collect. Accepted warranty units, which have been replaced, become the sole property of **BD**.

This warranty is in lieu of all other warranties or guaranties, either expressed or implied, and shall not extend to any consumer or to any person other than the original purchaser residing within the boundaries of the continental U.S. or Canada.

IN THE EVENT THAT THE BUYER DOES NOT AGREE WITH THIS AGREEMENT, THE BUYER MAY PROMPTLY RETURN THIS PRODUCT, IN A NEW AND UNUSED CONDITION, WITH A DATED PROOF OF PURCHASE, TO THE PLACE OF PURCHASE WITHIN THIRTY (30) DAYS FROM DATE OF PURCHASE FOR A FULL REFUND.

BD Engine Brake Inc.

Plant Address: Unit A10, 33733 King Rd, Abbotsford, BC, Canada V2S 7M9

U.S. Shipping: #88-446 Harrison St, Sumas, WA 98295 U.S. Mailing: P.O. Box 231, Sumas, WA 98295

Phone: 604-853-6096 | Fax: 604-853-8749 | Internet: www.dieselpower.com