

Installation Instructions for Jeeps

Part # 000893, 000896, 000925, 000926

CAUTION: NOT ALL VEHICLES CONFORM TO PUBLISHED SPECIFICATIONS! TEST FIT THIS ASSEMBLY IN YOUR TRUCK BEFORE PAINTING OR ALTERING IN ANY WAY. ONLY ASSEMBLIES IN NEW CONDITION WILL BE ACCEPTED FOR RETURN OR EXCHANGE.

REMOVAL:

1. Engage the steering column / ignition switch lock with the steering wheel and wheels centered. (**NOTE** It may be necessary to remove the upper & lower bolts prior to locking ignition for accessibility)
2. Remove the stock steering assembly by removing the bolts that attach it to the steering box and steering column shafts. These connections are often rusty and penetrating oil or a few taps with a hammer may be needed to separate the joints from the shafts.

INSTALLATION:

3. Fully collapse the Borgeson shaft assembly. Install the Double D column end in the universal joint to the depth shown in Figure B. The column universal joint will be secured with two set screws as shown in Figure C. Tighten the short set screw against the shaft. The longer of the set screws must pass through one wall of the tube only. If the long set screw does not line up with an existing hole in the tube, a 3/8" diameter hole must be drilled through one wall of the tube only. Mark the shaft and remove the universal joint before drilling the hole; do not drill through the universal joint. The set screw should pass through this hole and bear against the opposite wall of the tube. Reinstall the universal joint and tighten both set screws and then tighten lock nuts.
4. Slide the splined universal joint over the steering box input shaft by extending the telescoping shaft. A seat must be provided for the set screw as shown in Figure A. (**NOTE** The existing factory flat spot will not be used) Tighten the set screw to mark the shaft and then remove the universal joint from the shaft to file a new flat spot on the splined shaft. Install the universal joint and tighten the set screw into the seat and then tighten the lock nut.
5. After approximately 100 miles, retighten all setscrews and then lock nuts. If you wish to use a product such as Loctite, we recommend Loctite 222 for ease of removal.

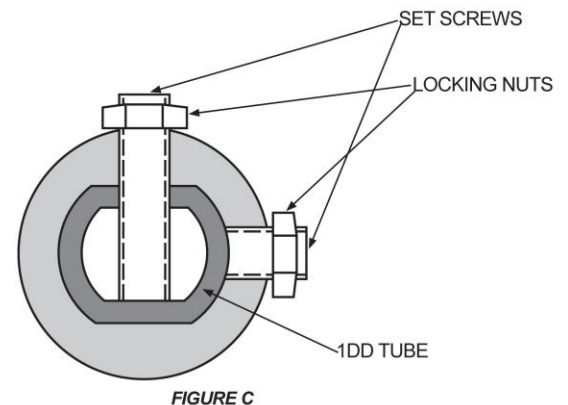
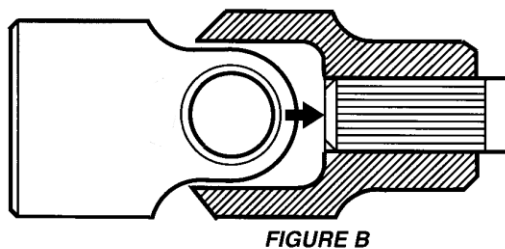
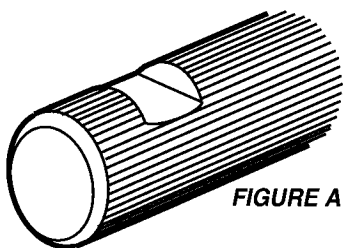

Borgeson Universal Co., Inc.
91 Technology Park Dr. Torrington, CT 06790
860-482-8283 www.borgeson.com