



11030 INSTALLATION INSTRUCTIONS



Safety glasses should be worn at all times while installing this product.

YEARS: 2008-2013

MAKE: MERCEDES BENZ

MODEL: C-CLASS

STYLE: SEDAN

WARNING: NEVER EXCEED YOUR VEHICLE MANUFACTURER'S RECOMMENDED TOWING CAPACITY

WEIGHT CARRYING:
TRAILER WEIGHT: 2,000 LBS.
TONGUE WEIGHT: 200 LBS.

WARNING:
WE RECOMMEND THE USE OF 18050 STABILIZING STRAPS FOR ALL NON-TRAILER (WHEEL-LESS) LOADS. PLEASE SEE THE CURT CATALOG OR VISIT US ONLINE AT WWW.CURTMFG.COM FOR FURTHER INFORMATION.

INSTALLATION TIME: 30 MIN.

THE INSTALL TIME LISTED IS FOR PROFESSIONAL INSTALLERS. IF YOU ARE HESITANT TO UNDERTAKE THIS TASK ON YOUR OWN, CONTACT AN AUTHORIZED CURT INSTALLER FOR ADDITIONAL ASSISTANCE.

INSTALLATION TIPS:

1. BEFORE YOU BEGIN INSTALLATION, READ ALL INSTRUCTIONS THOROUGHLY.
2. TO EASE INSTALLATION, 2 PEOPLE MAY BE REQUIRED.
3. USING PROPER TOOLS WILL GREATLY IMPROVE THE QUALITY OF THE INSTALL AND REDUCE THE TIME REQUIRED.
4. NEED HELP OR HAVE SOME QUESTIONS? CALL TECHNICAL SUPPORT AT 800.798.0813



VEHICLE PHOTO:



INSTALLATION REQUIRES:

 RATCHET	 TORQUE WRENCH	 9" SOCKET EXTENSION
 3/4" 10mm SOCKET	 POWER DRILL	 DRILL BIT 1/16"-17/32"
 MARKER	 CENTER PUNCH	 DIE GRINDER
 MASKING TAPE	 SAFETY GLASSES	

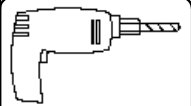
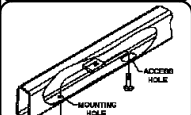
LEVEL OF DIFFICULTY: MODERATE

EASY	MODERATE	HARD
	DRILLING REQUIRED	
	FISHWIRE REQUIRED	
	FASCIA TRIMMING MAY BE REQUIRED ON C300	

HITCH ILLUSTRATION:

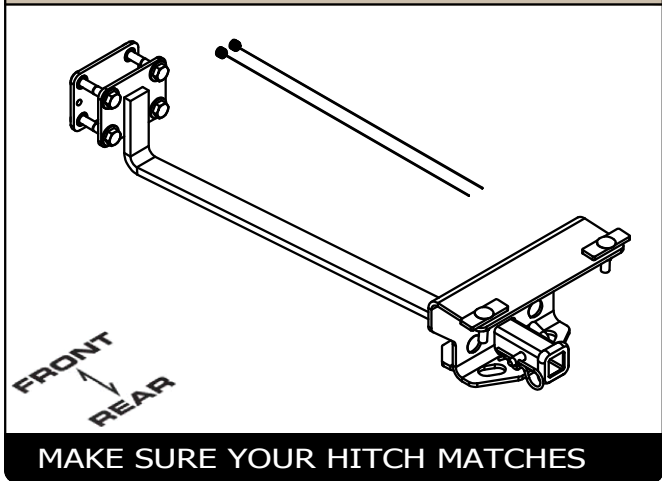

PERIODICALLY CHECK THIS RECEIVER HITCH TO ENSURE ALL FASTENERS ARE TIGHT AND ALL STRUCTURAL COMPONENTS ARE SOUND

CURT Manufacturing Inc. warrants this product to be free of defects in material and/or workmanship at the time of retail purchase by the original purchaser. If the product is found to be defective, Curt Manufacturing Inc. may repair or replace the product at their option, when the product is returned, prepaid, with proof of purchase. Alteration to, misuse of, or improper installation of this product voids the warranty. Curt Manufacturing Inc.'s liability is limited to repair or replacement of products found to be defective, and specifically excludes liability for incidental or consequential loss or damage.

For more information log onto www.curtmfg.com, & for helpful towing tips log onto www.hitchinfo.com

INSTALLATION WALKTHROUGH:

Parts List			
ITEM	QTY	PART NUMBER	DESCRIPTION
1	2	1_2 FISHWIRE	1/2" FISHWIRE
2	2	1/2-13 x 1 1/4	CARRIAGE BOLT
3	4	HFN 1213	HEX FLANGE NUT
4	2	1/2 - 13 x 2"	CARRIAGE BOLT
5	2	CM-SP6	.250 x 1.00 x 3.00" SQUARE HOLE SPACER
6	4	1/2 - 13 x 2 1/2	HEX BOLT
7	4	1/2"	CONICAL TOOTHED WASHER

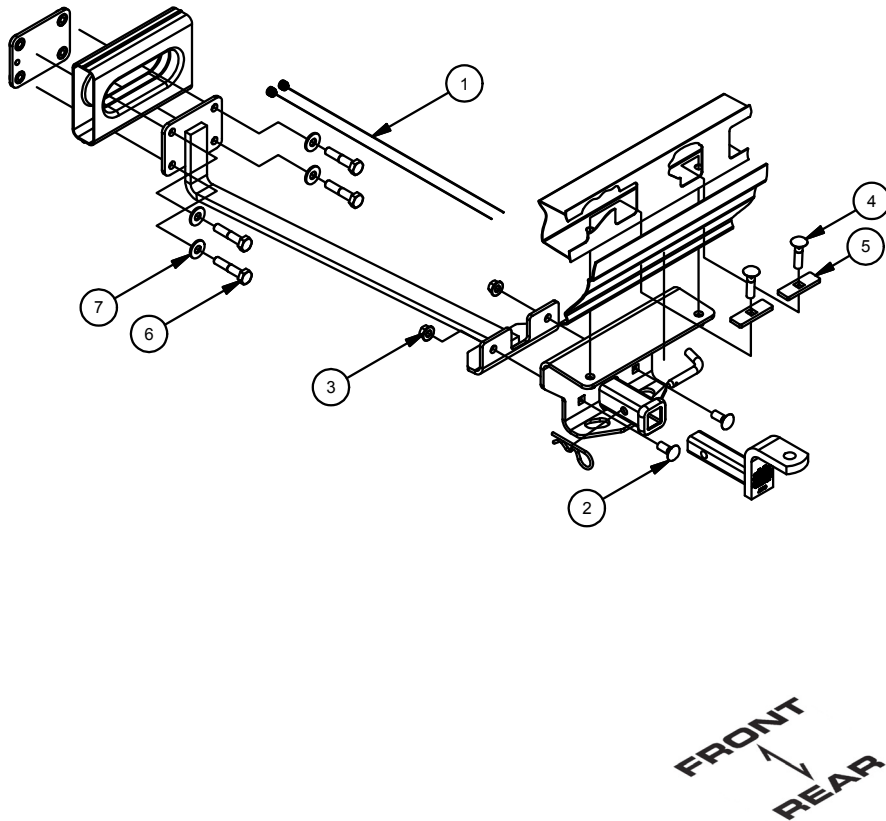

1. Remove (2) fasteners which attach fascia to trunk pan.



2. Raise nut plate and mounting strap into position around the vehicle crossmember. Secure using 1/2-13 x 2 1/2" hex bolts and 1/2" conical toothed washers.



INSTALLATION WALKTHROUGH:

3. Raise hitch weldment past fascia lip and secure to mounting strap using 1/2-13 x 1 1/4" carriage bolts and 1/2-13 flange nuts.

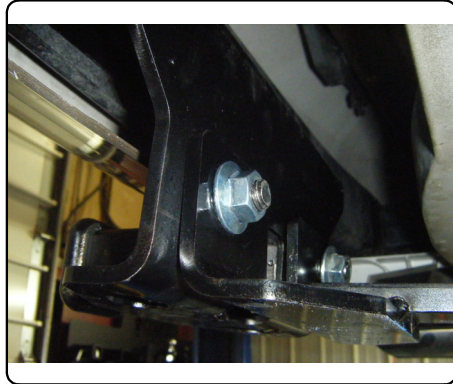

4. Press hitch against the bottom of the bumper beam. (NOTE: Be sure hitch is centered on vehicle.) Using the hitch as a template mark hole locations. Lower hitch and drill marked locations. (NOTE: Start with a small drill bit for pilot hole. A die grinder with a cone shaped bit may be easier than drill bits.)

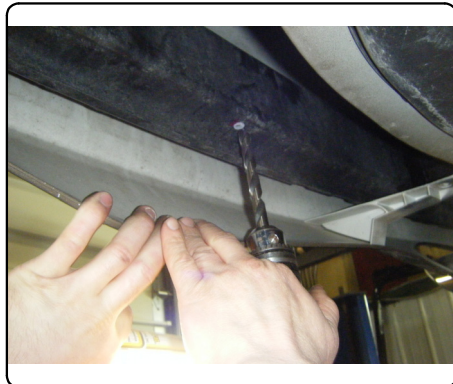

5. Fishwire 1/2-13 x 2" carriage bolt and SP6 spacers through access hole between the fascia and the back of the bumper beam and out the holes drilled in STEP 4. Raise hitch back into position and secure with 1/2-13 flange nuts.



FISHWIRE TECHNIQUE
INSERT COILED END OF FISHWIRE TOOL THROUGH HITCH MOUNTING HOLE IN VEHICLE FRAME RAIL AND OUT THE ACCESS HOLE. PASS COILED END OF FISHWIRE THROUGH SPACER AND THREAD BOLT INTO COIL. KINK WIRE TO KEEP SPACER SEPERATE FROM BOLT AS SHOWN. PULL FISHWIRE, SPACER, AND BOLT THROUGH FRAME AND OUT MOUNTING HOLE. USE FISHWIRE TO GUIDE HITCH DURING MOUNTING AND PREVENT LOSS OF BOLT / SPACER INSIDE FRAME RAIL.
NOTE: SOME VEHICLES MAY FISHWIRE THROUGH END OF FRAME

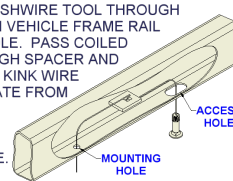

6. Torque all 1/2" fasteners to 75 ft-lbs. Re-install fasteners removed in STEP 1.
Install is complete.



11030**2008-2013 MERCEDES BENZ C-CLASS SEDAN**

6/17/2014

GROSS LOAD CAPACITY WHEN USED AS A WEIGHT CARRYING HITCH: 2,000 LBS. TRAILER WEIGHT & 200 LBS. TONGUE WEIGHT.

DO NOT EXCEED VEHICLE MANUFACTURER'S RECOMMENDED TOWING CAPACITY.

WARNING: ALL NON-TRAILER LOADS APPLIED TO THIS PRODUCT MUST BE SUPPORTED BY 18050 STABILIZING STRAPS.

** FAILURE TO PROPERLY SUPPORT NON-TRAILER LOADS WILL VOID PRODUCT WARRANTY**

HAVING INSTALLATION QUESTIONS? CALL TECHNICAL SUPPORT AT 1-800-798-0813

Parts List			
ITEM	QTY	PART NUMBER	DESCRIPTION
1	2	1_2 FISHWIRE	1/2" FISHWIRE
2	2	1/2-13 x 1 1/4	CARRIAGE BOLT
3	4	HFN 1213	HEX FLANGE NUT
4	2	1/2 - 13 x 2"	CARRIAGE BOLT
5	2	CM-SP6	.250 x 1.00 x 3.00" SQUARE HOLE SPACER
6	4	1/2 - 13 x 2 1/2	HEX BOLT
7	4	1/2"	CONICAL TOOTHED WASHER

TOOLS REQUIRED
RATCHET
RATCHET EXTENSION
10mm & 3/4" SOCKET
DRILL
1/16"-17/32" DRILL BITS
MARKER
TORQUE WRENCH
OPTIONAL: DIE GRINDER WITH CONE SHAPED BIT

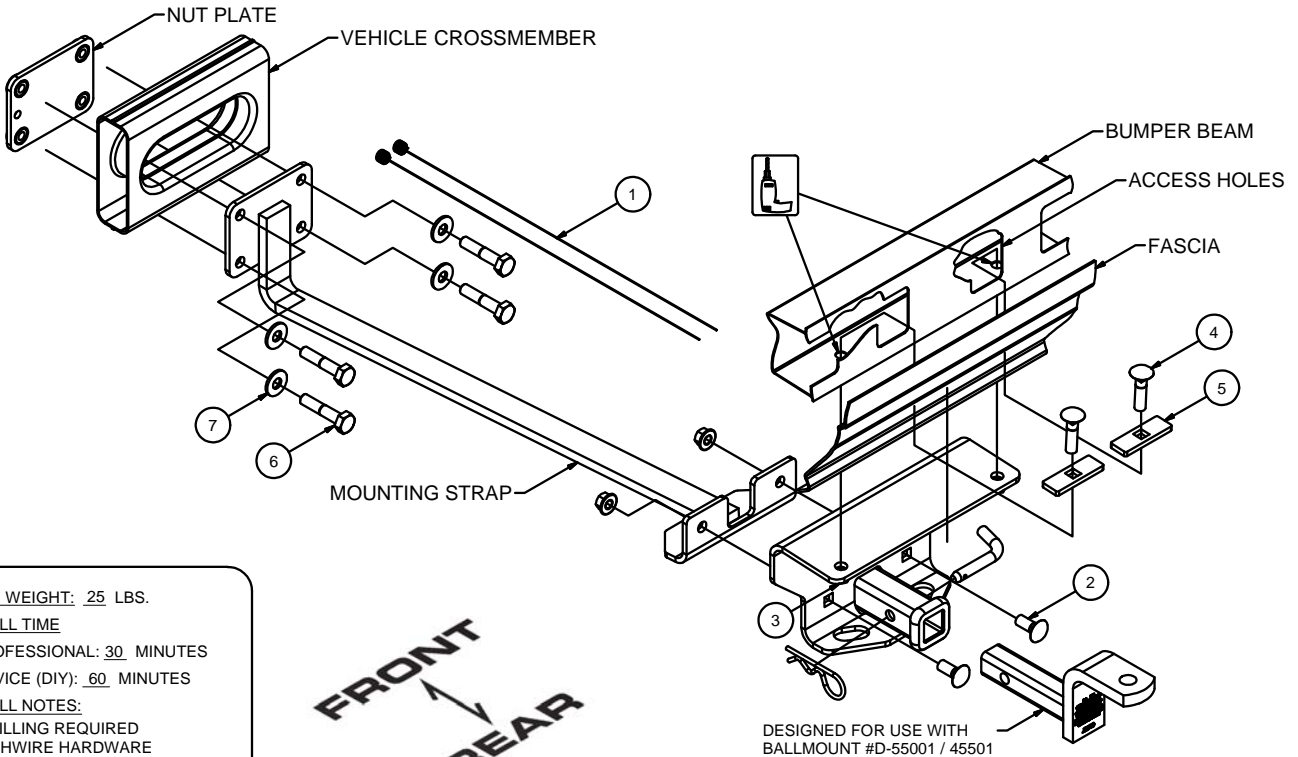
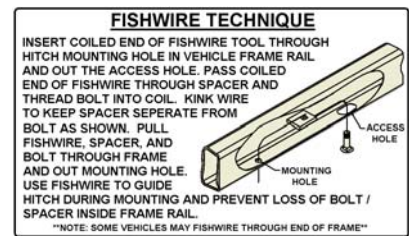

HITCH WEIGHT: 25 LBS.

INSTALL TIME

PROFESSIONAL: 30 MINUTES

NOVICE (DIY): 60 MINUTES

INSTALL NOTES:

- DRILLING REQUIRED
- FISHWIRE HARDWARE
- MINOR FACIA TRIMMING MAY BE REQUIRED ON THE C300

INSTALLATION STEPS

1. Remove (2) fasteners which attach fascia to trunk pan.
2. Raise nut plate and mounting strap into position around the vehicle crossmember. Secure using 1/2-13 x 2 1/2" hex bolts and 1/2" conical toothed washers.
3. Raise hitch weldment past fascia lip and secure to mounting strap using 1/2-13 x 1 1/4" carriage bolts and 1/2-13 flange nuts.
4. Press hitch against the bottom of the bumper beam. (NOTE: Be sure hitch is centered on vehicle.) Using the hitch as a template mark hole locations.
5. Lower hitch and drill marked locations. (NOTE: Start with a small drill bit for pilot hole. A die grinder with a cone shaped bit may be easier than drill bits.)
6. Fishwire 1/2-13 x 2" carriage bolt and SP6 spacers through the access holes between the fascia and the back of the bumper beam and out the holes drilled in STEP 4. Raise hitch back into position and secure with 1/2-13 flange nuts.
7. Torque all 1/2" fasteners to 75 ft-lbs and re-install fasteners removed in STEP 1.

PERIODICALLY CHECK THIS RECEIVER HITCH TO ENSURE THAT ALL FASTENERS ARE TIGHT AND THAT ALL STRUCTURAL COMPONENTS ARE SOUND.

Curt Manufacturing Inc., warrants this product to be free of defects in material and/or workmanship at the time of retail purchase by the original purchaser. If the product is found to be defective, Curt Manufacturing Inc., may repair or replace the product, at their option, when the product is returned, prepaid, with proof of purchase. Alteration to, misuse of, or improper installation of this product voids the warranty. Curt Manufacturing Inc.'s liability is limited to repair or replacement of products found to be defective, and specifically excludes liability for incidental or consequential loss or damage.