



11065 INSTALLATION INSTRUCTIONS



Safety glasses should be worn at all times while installing this product.

YEARS: 2010

MAKE: VOLVO

MODEL: C70

STYLE: CONVERTIBLE

WARNING: NEVER EXCEED YOUR VEHICLE MANUFACTURER'S RECOMMENDED TOWING CAPACITY





WEIGHT CARRYING:
TRAILER WEIGHT: 2,000 LBS.
TONGUE WEIGHT: 200 LBS.

WARNING:
WE RECOMMEND THE USE OF 18050 STABILIZING STRAPS FOR ALL NON-TRAILER (WHEEL-LESS) LOADS. PLEASE SEE THE CURT CATALOG OR VISIT US ONLINE AT WWW.CURTMFG.COM FOR FURTHER INFORMATION.

INSTALLATION TIME: 20 MIN.

THE INSTALL TIME LISTED IS FOR PROFESSIONAL INSTALLERS. IF YOU ARE HESITANT TO UNDERTAKE THIS TASK ON YOUR OWN, CONTACT AN AUTHORIZED CURT INSTALLER FOR ADDITIONAL ASSISTANCE.

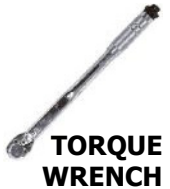

INSTALLATION REQUIRES:

 RATCHET	 10mm 3/4" SOCKET	 TORQUE WRENCH
 WIRE PIPE BRUSH	 SAFETY GLASSES	

INSTALLATION TIPS:

- BEFORE YOU BEGIN INSTALLATION, READ ALL INSTRUCTIONS THOROUGHLY.
- TO EASE INSTALLATION, 2 PEOPLE MAY BE REQUIRED.
- USING PROPER TOOLS WILL GREATLY IMPROVE THE QUALITY OF THE INSTALL AND REDUCE THE TIME REQUIRED.
- NEED HELP OR HAVE SOME QUESTIONS? CALL TECHNICAL SUPPORT AT 800.798.0813

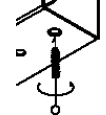
LEVEL OF DIFFICULTY: EASY

EASY	MODERATE	HARD
	LOWER EXHAUST	
	WELDNUT CLEANING MAY BE REQUIRED	
	NO DRILLING REQUIRED	

VEHICLE PHOTO:



REPRESENTATIVE PHOTO

HITCH ILLUSTRATION:

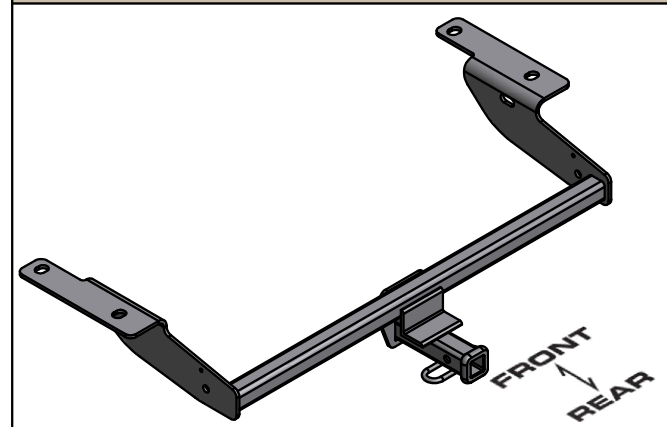

MAKE SURE YOUR HITCH MATCHES

PERIODICALLY CHECK THIS RECEIVER HITCH TO ENSURE ALL FASTENERS ARE TIGHT AND ALL STRUCTURAL COMPONENTS ARE SOUND

CURT Manufacturing Inc. warrants this product to be free of defects in material and/or workmanship at the time of retail purchase by the original purchaser. If the product is found to be defective, Curt Manufacturing Inc. may repair or replace the product at their option, when the product is returned, prepaid, with proof of purchase. Alteration to, misuse of, or improper installation of this product voids the warranty. Curt Manufacturing Inc.'s liability is limited to repair or replacement of products found to be defective, and specifically excludes liability for incidental or consequential loss or damage.

For more information log onto www.curtmfg.com, & for helpful towing tips log onto www.hitchinfo.com

INSTALLATION WALKTHROUGH:

Parts List			
ITEM	QTY	PART NUMBER	DESCRIPTION
1	4	M8-1.25 x 35	HEX BOLT
2	4	3/8"	CONICAL TOOTHED WASHER
3	2	1/2-13 x 1 1/2	CARRIAGE BOLT
4	2	CM-SP12	.250 x 1.00 x 2.00" SQUARE HOLE SPACER
5	2	HFN 1213	HEX FLANGE NUT

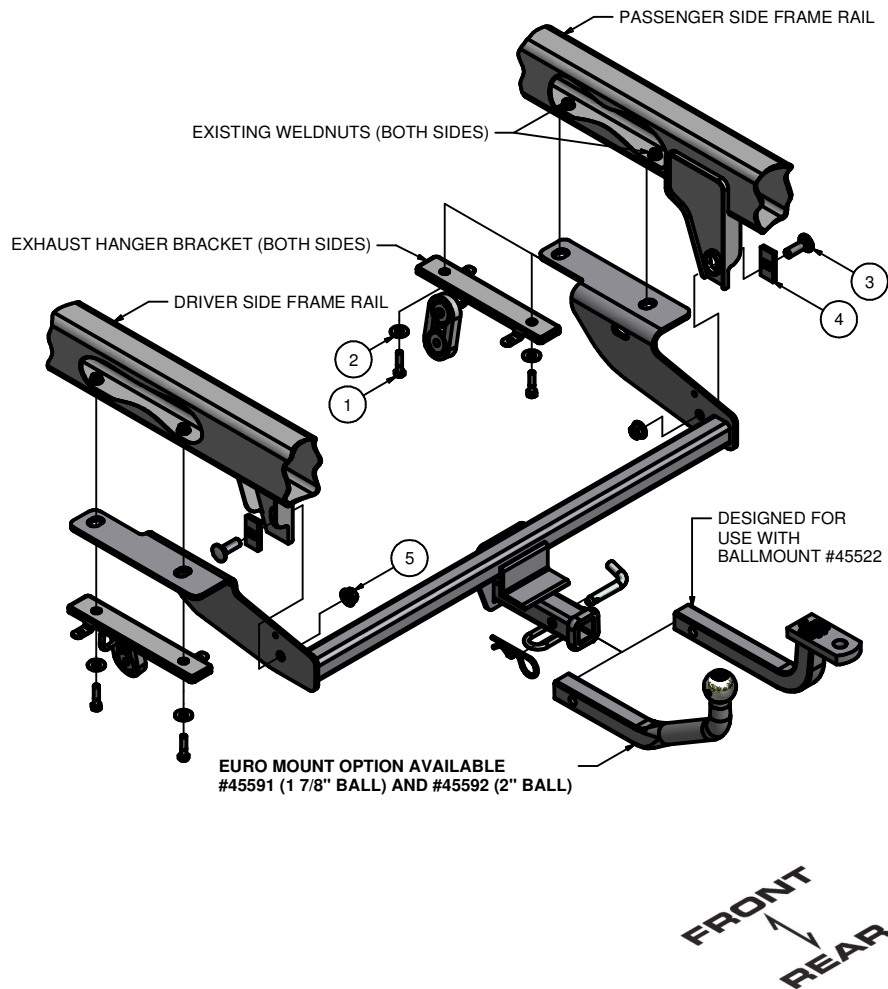

1. Lower exhaust by removing (2) M8 fasteners from each exhaust hanger bracket. Return (4) M8 fasteners to vehicle owner.

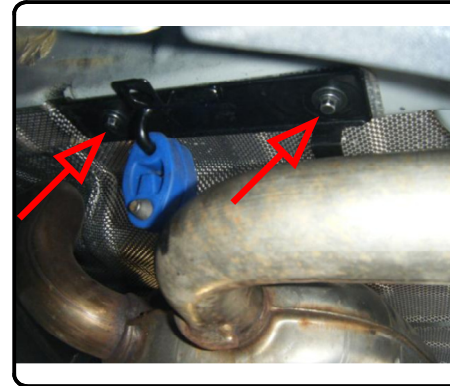

2. Raise hitch into position. (NOTE: Hitch will be sandwiched between frame and exhaust hanger brackets)



INSTALLATION WALKTHROUGH:

3. Loosely attach hitch to vehicle tie down brackets using the supplied 1/2" hardware and SP12 spacers, as shown.



4. Secure exhaust hanger brackets and hitch to frame using the supplied M8 fasteners and 3/8" conical tooth washers.



5. Torque all M8 fasteners to 17 ft-lbs and all 1/2" hardware to 75 ft-lbs.



6. Install is complete.



11065**VOLVO C70****8/4/2010****GROSS LOAD CAPACITY WHEN USED AS A WEIGHT CARRYING HITCH: 2,000 LBS. TRAILER WEIGHT & 200 LBS. TONGUE WEIGHT.**

DO NOT EXCEED VEHICLE MANUFACTURER'S RECOMMENDED TOWING CAPACITY.

WARNING: ALL NON-TRAILER LOADS APPLIED TO THIS PRODUCT MUST BE SUPPORTED BY 18050 STABILIZING STRAPS.

** FAILURE TO PROPERLY SUPPORT NON-TRAILER LOADS WILL VOID PRODUCT WARRANTY**

HAVING INSTALLATION QUESTIONS? CALL TECHNICAL SUPPORT AT 1-800-798-0813

Parts List				
ITEM	QTY	PART NUMBER	DESCRIPTION	
1	4	M8-1.25 x 35	HEX BOLT	
2	4	3/8"	CONICAL TOOTHED WASHER	
3	2	1/2-13 x 1 1/2	CARRIAGE BOLT	
4	2	CM-SP12	.250 x 1.00 x 2.00" SQUARE HOLE SPACER	
5	2	HFN 1213	HEX FLANGE NUT	

TOOLS REQUIRED
RATCHET
10mm & 3/4" SOCKETS
TORQUE WRENCH

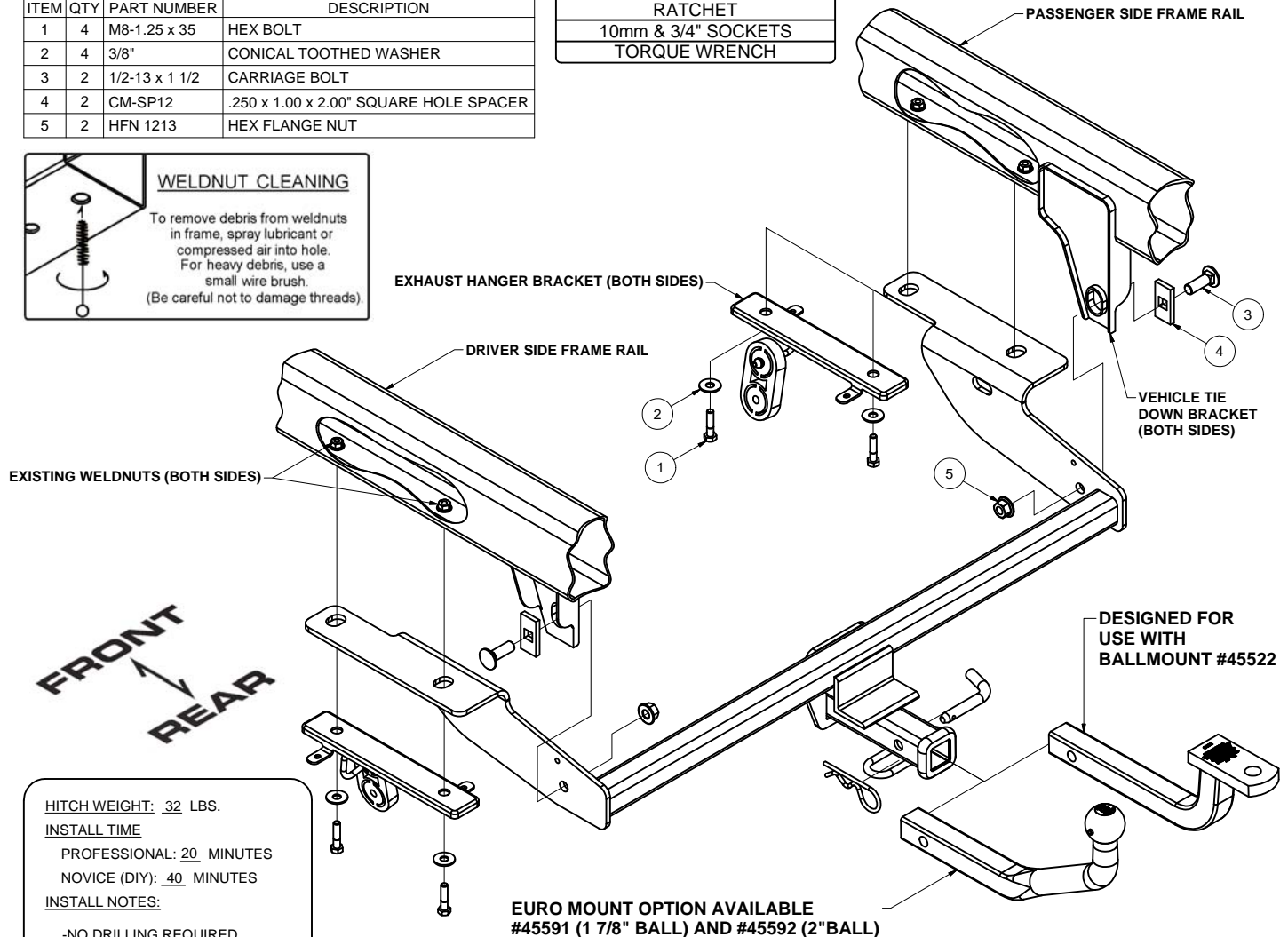
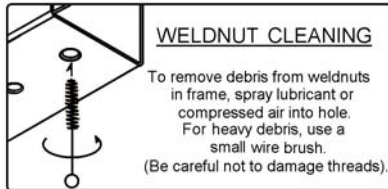
**HITCH WEIGHT:** 32 LBS.**INSTALL TIME**

PROFESSIONAL: 20 MINUTES

NOVICE (DIY): 40 MINUTES

INSTALL NOTES:

- NO DRILLING REQUIRED
- LOWER EXHAUST

INSTALLATION STEPS

1. Lower exhaust by removing (2) M8 fasteners from each exhaust hanger bracket. Return (4) M8 fasteners to vehicle owner.
2. Raise hitch into position and loosely attach it to vehicle tie down brackets using the supplied 1/2" hardware and SP12 spacers, as shown above. (NOTE: Hitch will be sandwiched between frame and exhaust hanger brackets)
3. Secure exhaust hanger brackets and hitch to frame using the supplied M8 fasteners and 3/8" conical tooth washers.
4. Torque all M8 fasteners to 17 ft-lbs and all 1/2" hardware to 75 ft-lbs.

PERIODICALLY CHECK THIS RECEIVER HITCH TO ENSURE THAT ALL FASTENERS ARE TIGHT AND THAT ALL STRUCTURAL COMPONENTS ARE SOUND.

Curt Manufacturing Inc., warrants this product to be free of defects in material and/or workmanship at the time of retail purchase by the original purchaser. If the product is found to be defective, Curt Manufacturing Inc., may repair or replace the product, at their option, when the product is returned, prepaid, with proof of purchase. Alteration to, misuse of, or improper installation of this product voids the warranty. Curt Manufacturing Inc.'s liability is limited to repair or replacement of products found to be defective, and specifically excludes liability for incidental or consequential loss or damage.