



Safety glasses should be worn at all times while installing this product.

YEARS: 2011-PRESENT

MAKE: LEXUS

MODEL: CT 200h

STYLE: HATCHBACK

**WARNING: NEVER EXCEED YOUR VEHICLE MANUFACTURER'S RECOMMENDED TOWING CAPACITY**

**WEIGHT CARRYING:**  
 TRAILER WEIGHT: 2,000 LBS.  
 TONGUE WEIGHT: 200 LBS.

**WARNING:**  
 WE RECOMMEND THE USE OF 18050 STABILIZING STRAPS FOR ALL NON-TRAILER (WHEEL-LESS) LOADS. PLEASE SEE THE CURT CATALOG OR VISIT US ONLINE AT [WWW.CURTMFG.COM](http://WWW.CURTMFG.COM) FOR FURTHER INFORMATION.

**INSTALLATION TIME: 15 MIN.**

THE INSTALL TIME LISTED IS FOR PROFESSIONAL INSTALLERS. IF YOU ARE HESITANT TO UNDERTAKE THIS TASK ON YOUR OWN, CONTACT AN AUTHORIZED CURT INSTALLER FOR ADDITIONAL ASSISTANCE.

**INSTALLATION REQUIRES:**

 RATCHET	 TORQUE WRENCH	 9" SOCKET EXTENSION
 19mm 17mm 10mm SOCKET	 SCREW DRIVER	 SAFETY GLASSES

**INSTALLATION TIPS:**

- BEFORE YOU BEGIN INSTALLATION, READ ALL INSTRUCTIONS THOROUGHLY.
- TO EASE INSTALLATION, 2 PEOPLE MAY BE REQUIRED.
- USING PROPER TOOLS WILL GREATLY IMPROVE THE QUALITY OF THE INSTALL AND REDUCE THE TIME REQUIRED.
- NEED HELP OR HAVE SOME QUESTIONS? CALL TECHNICAL SUPPORT AT 800.798.0813

**LEVEL OF DIFFICULTY: EASY**

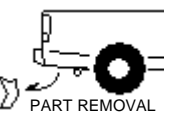
EASY	MODERATE	CHALLENGING
	- NO DRILLING REQUIRED	
	- TOW LOOP REMOVAL	

**VEHICLE PHOTO:**



REPRESENTATIVE PHOTO

**HITCH ILLUSTRATION:**

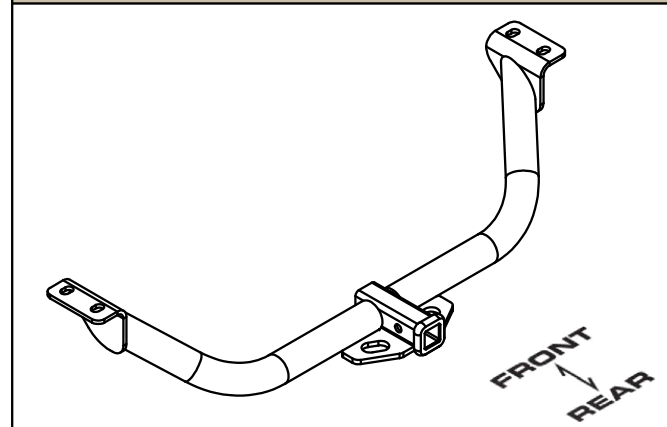

MAKE SURE YOUR HITCH MATCHES

**PERIODICALLY CHECK THIS RECEIVER HITCH TO ENSURE ALL FASTENERS ARE TIGHT AND ALL STRUCTURAL COMPONENTS ARE SOUND**

CURT Manufacturing LLC. warrants this product to be free of defects in material and/or workmanship at the time of retail purchase by the original purchaser. If the product is found to be defective, Curt Manufacturing LLC. may repair or replace the product at their option, when the product is returned, prepaid, with proof of purchase. Alteration to, misuse of, or improper installation of this product voids the warranty. Curt Manufacturing LLC.'s liability is limited to repair or replacement of products found to be defective, and specifically excludes liability for incidental or consequential loss or damage.

For more information log onto [www.curtmfg.com](http://www.curtmfg.com), & for helpful towing tips log onto [www.hitchinfo.com](http://www.hitchinfo.com)

## INSTALLATION WALKTHROUGH:

Parts List			
ITEM	QTY	PART NUMBER	DESCRIPTION
1	4	M12-1.25 x 30mm	HEX BOLT
2	4	1/2"	CONICAL TOOTHED WASHER

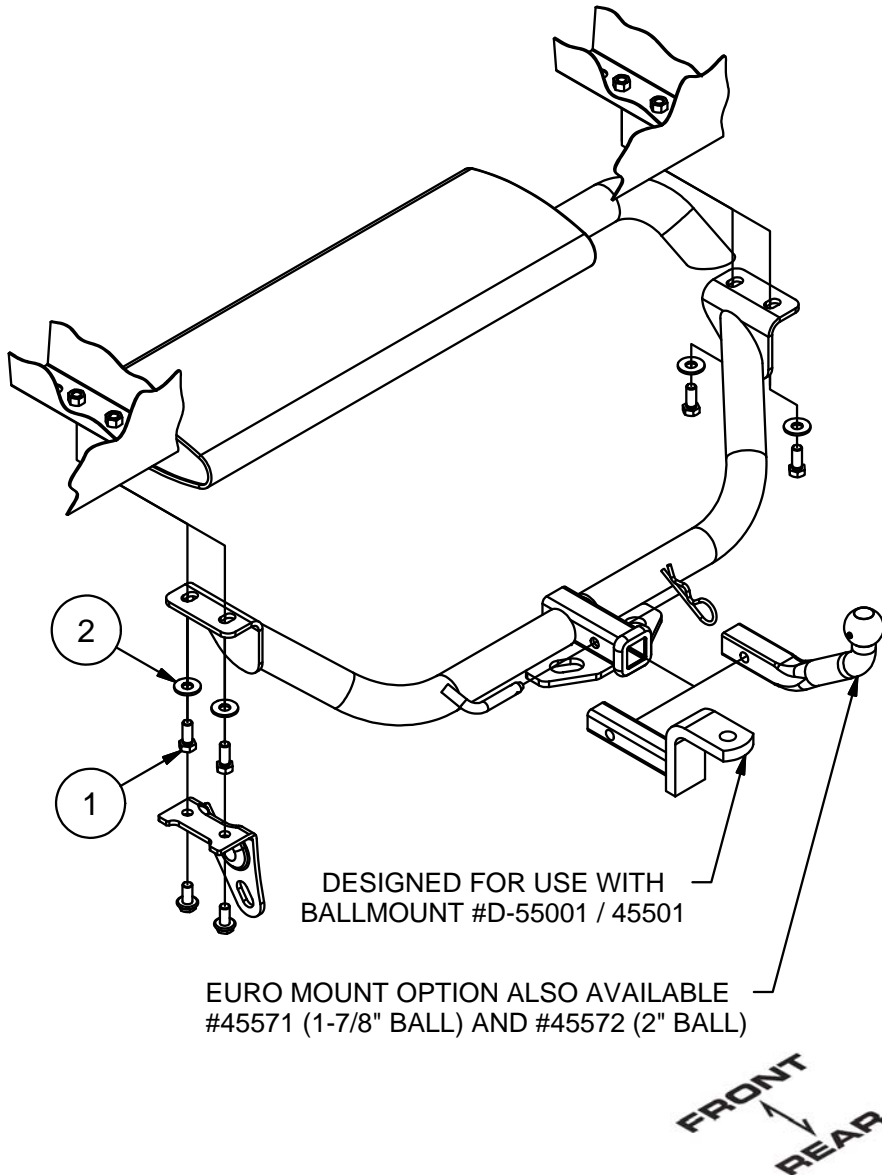

1. Remove the driver side underbody panel by removing (5) fasteners. Panel and fasteners will be reinstated later.



2. Remove (2) tow loop bolts and tow loop. Return tow loop and bolts to owner. **Note:** The first photo shows the tow loop covered by the underbody panel, the second shows the underbody panel removed.



## INSTALLATION WALKTHROUGH:

3. Raise hitch into position and secure using M12-1.25 x 30mm and 1/2" conical toothed washers. **Note:** For ease of installation raise the passenger side into position first.

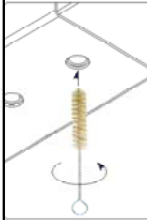

### WELDNUT CLEANING

To remove debris from weldnuts in frame, spray lubricant or compressed air into hole. For heavy debris, use a small wire brush. (Be careful not to damage threads)



4. Torque all M12 hardware to 72 ft-lbs. Reinstall underbody panel removed in Step (1).



Install Complete



11200

LEXUS CT 200h

5/19/2011

GROSS LOAD CAPACITY WHEN USED AS A WEIGHT CARRYING HITCH: 2,000 LBS. TRAILER WEIGHT & 200 LBS. TONGUE WEIGHT.

\*\*\*DO NOT EXCEED VEHICLE MANUFACTURER'S RECOMMENDED TOWING CAPACITY.\*\*\*

WARNING: ALL NON-TRAILER LOADS APPLIED TO THIS PRODUCT MUST BE SUPPORTED BY 18050 STABILIZING STRAPS.

\*\* FAILURE TO PROPERLY SUPPORT NON-TRAILER LOADS WILL VOID PRODUCT WARRANTY\*\*

HAVING INSTALLATION QUESTIONS? CALL TECHNICAL SUPPORT AT 1-800-798-0813

Parts List			
ITEM	QTY	PART NUMBER	DESCRIPTION
1	4	M12-1.25 x 30mm	HEX BOLT
2	4	1/2"	CONICAL TOOTHED WASHER

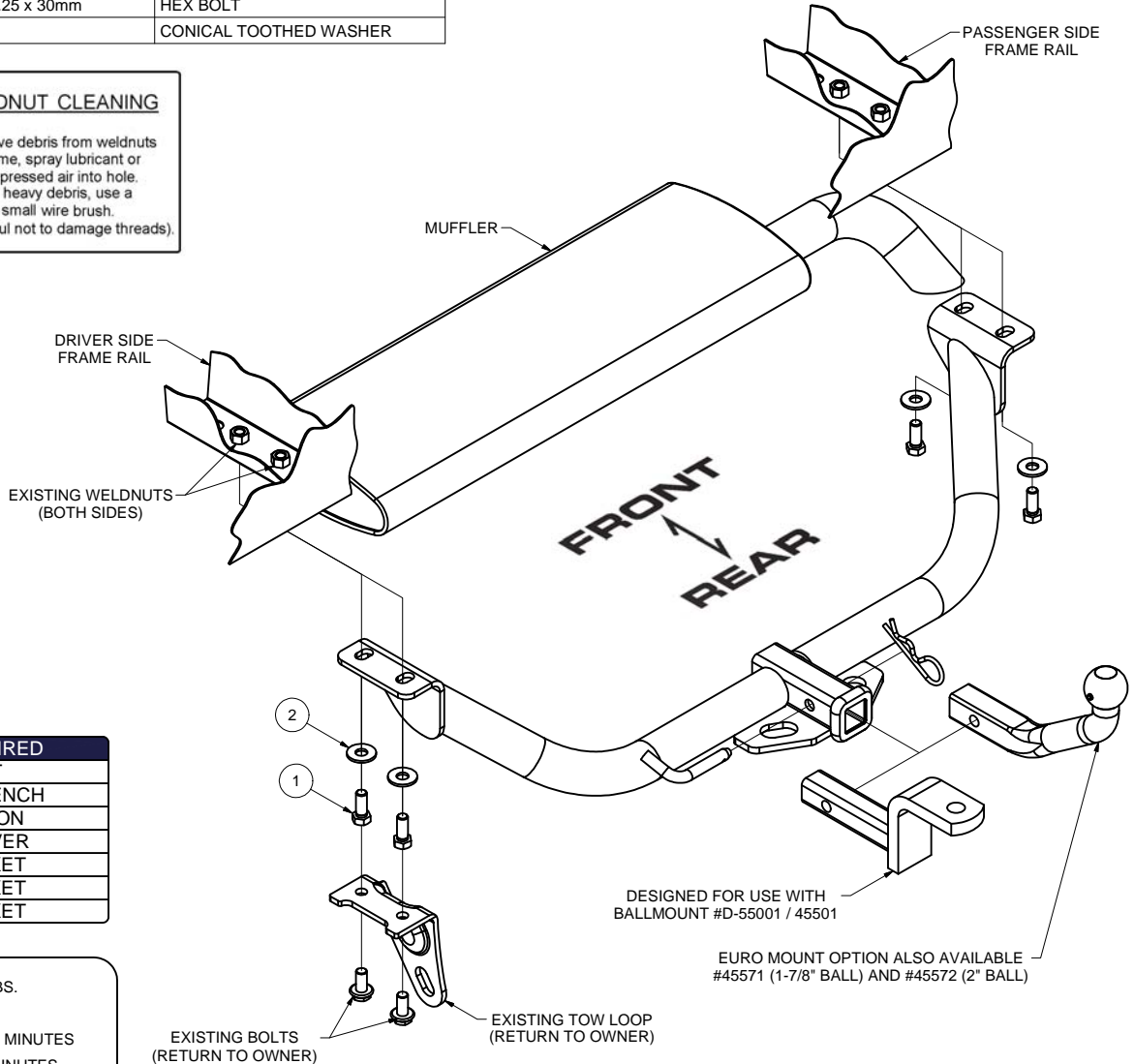
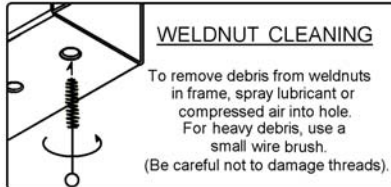

TOOLS REQUIRED
RATCHET
TORQUE WRENCH
9" EXTENSION
SCREWDRIVER
19mm SOCKET
17mm SOCKET
10mm SOCKET

**HITCH WEIGHT:** 23 LBS.  
**INSTALL TIME**  
 PROFESSIONAL: 15 MINUTES  
 NOVICE (DIY): 30 MINUTES  
**INSTALL NOTES:**  
 - NO DRILLING REQUIRED  
 - TOW LOOP REMOVAL

**INSTALLATION STEPS**

1. Remove the driver side underbody panel by removing (5) fasteners. Panel and fasteners will be reinstalled later.
2. Remove (2) tow loop bolts and tow loop. Return tow loop and bolts to owner.
3. Raise hitch into position and secure using M12-1.25 x 30mm and 1/2" conical toothed washers. (See Weldnut Cleaning Detail)  
**Note:** For ease of installation raise the passenger side into position first.
4. Torque all M12 hardware to 72 ft-lbs.
5. Reinstall underbody panel removed in Step (1).

PERIODICALLY CHECK THIS RECEIVER HITCH TO ENSURE THAT ALL FASTENERS ARE TIGHT AND THAT ALL STRUCTURAL COMPONENTS ARE SOUND.

Curt Manufacturing LLC., warrants this product to be free of defects in material and/or workmanship at the time of retail purchase by the original purchaser. If the product is found to be defective, Curt Manufacturing LLC., may repair or replace the product, at their option, when the product is returned, prepaid, with proof of purchase. Alteration to, misuse of, or improper installation of this product voids the warranty. Curt Manufacturing LLC.'s liability is limited to repair or replacement of products found to be defective, and specifically excludes liability for incidental or consequential loss or damage.